

EMD-SL-V-UV-300

Electronic monitoring relay for undervoltage monitoring of direct and alternating voltages in single-phase networks

INTERFACE

Data sheet
101746_en_04

© PHOENIX CONTACT - 09/2009



1 Description

Increasingly higher demands are being placed on safety and system availability – across all sectors. Processes are becoming more and more complex, not only in mechanical engineering and the chemical industry, but also in plant and automation technology. Demands on power engineering are also increasing constantly.

Error-free and therefore cost-effective operation can only be achieved through continuous monitoring of important network and system parameters. Electronic monitoring relays in the EMD series are available for a wide range of monitoring tasks to avoid the consequences of errors or to keep them within limits.

The operating states are indicated using colored LEDs, errors that may occur can be sent to a control system via a floating contact or can shut down a part of the system. Some device versions are equipped with startup and response delays in order to briefly tolerate measured values outside the set monitoring range.

Features

- Undervoltage monitoring
- Adjustable threshold values
- Adjustable hysteresis
- Adjustable response delay
- Power supply via power module can be selected

**WARNING: Risk of electric shock**

Never carry out work when voltage is present.



Make sure you always use the latest documentation.
It can be downloaded at www.phoenixcontact.net/download.

2 Ordering data

Description	Type	Order No.	Pcs. / Pkt.
Electronic monitoring relay for undervoltage monitoring of direct and alternating voltages in single-phase networks	EMD-SL-V-UV-300	2866035	1

Accessories	Type	Order No.	Pcs. / Pkt.
Power modules, pluggable, for EMD-SL-..., supply voltage: 20 V DC ... 30 V DC	EMD-SL-PS- 24DC	2885359	1
Power modules, pluggable, for EMD-SL-..., supply voltage: 20.2...26.4 V AC	EMD-SL-PS- 24AC	2866103	1
Power modules, pluggable, for EMD-SL-..., supply voltage: 88...121 V AC	EMD-SL-PS-110AC	2866116	1
Power modules, pluggable, for EMD-SL-..., supply voltage: 108 V AC ... 132 V AC	EMD-SL-PS-120AC	2885731	1
Power modules, pluggable, for EMD-SL-..., supply voltage: 195...264 V AC	EMD-SL-PS-230AC	2866129	1

3 Technical data

Input data	
Input name	Measuring input
Measured value	DC, AC sine (48 Hz ... 63 Hz)
Protection	max. 20 A
Input voltage range	0 V ... 30 V AC/DC (connection terminal blocks: U1 and GND) 0 V ... 60 V AC/DC (connection terminal blocks: U2 and GND) 0 V ... 300 V AC/DC (connection terminal blocks: U3 and GND)
Maximum input voltage	100 V _{rms} (connection terminal blocks: U1 and GND) 150 V _{rms} (connection terminal blocks: U2 and GND) 440 V _{rms} (connection terminal blocks: U3 and GND)
Input resistance of voltage input	47 kΩ (connection terminal blocks: U1 and GND) 100 kΩ (connection terminal blocks: U2 and GND) 470 kΩ (connection terminal blocks: U3 and GND)
Maximum temperature coefficient	< 0.1 %/K
Setting range for response delay	0.2 s ... 10 s
Min. setting range	5 % ... 95 % (From U _N)
Max. setting range	10 % ... 100 % (From U _N)
Function	Undervoltage
Basic accuracy	± 5 % (of scale end value)
Setting accuracy	≤ 5 % (of scale end value)
Repeat accuracy	≤ 2 %
Recovery time	500 ms

Output data	
Contact type	1 floating PDT
Nominal insulation voltage	250 V AC (in acc. with IEC 60664-1)
Interrupting rating (ohmic load) max.	750 VA (3 A/250 V AC, module aligned, ≤ 5 mm spacing) 1250 VA (5 A/250 V AC, module not aligned, ≥ 5 mm spacing)
Output fuse	5 A (fast-blow)

Supply

Range of supply voltages	24 V AC ... 230 V AC (see Power modules) 24 V DC (see Power modules)
Frequency range	50 Hz ... 60 Hz
Nominal power consumption	2 VA (1.5 W)

General data

Mains type	1-phase
Service life mechanical	Approx. 2×10^7 cycles
Service life, electrical	2×10^5 cycles at ohmic load, 1000 VA
Switching frequency	max. 60 (per minute at 100 VA ohmic load) max. 6 (per minute at 1000 VA ohmic load)
Voltage drop	> 30 % (Relative to the supply voltage)
Operating mode	100% operating factor
Degree of protection	IP40 (housing) / IP20 (connection terminal blocks)
Pollution degree	2 (according to EN 50178)
Surge voltage category	III, basic insulation (as per EN 50178)
Rated insulation voltage	300 V (According to EN 50178)
Assembly	on TS 35 profile rail acc. to EN 60715
Mounting position	Any
Width	22.5 mm
Height	113 mm
Length	90 mm
Type of housing	Polyamide PA, self-extinguishing
Color	green
Weight	160 g

Connection data

Conductor cross section, solid	0.5 mm ² ... 2.5 mm ²
Conductor cross section, stranded	0.25 mm ² ... 2.5 mm ²
Stripping length	8 mm
Type of connection	Screw connection
Tightening torque	1 Nm

Ambient conditions

Ambient temperature (operation)	-25 °C ... 55 °C -25 °C ... 40 °C (corresponds to UL 508)
Ambient temperature (storage/transport)	-25 °C ... 70 °C
Permissible humidity (operation)	15 % ... 85 %
Climatic class	3K3 (in acc. with EN 60721)

Conformance / approvals

Conformity	CE compliant
UL, USA / Canada	UL/C-UL listed UL 508

Conformance with EMC directive 2004/108/EC

Immunity to interference according to	EN 61000-6-2
Emitted interference according to	EN 61000-6-3

Conformance with LV directive 2006/95/EC

Electronic equipm. for electrical power installations according to	EN 50178
--	----------

4 Block diagram

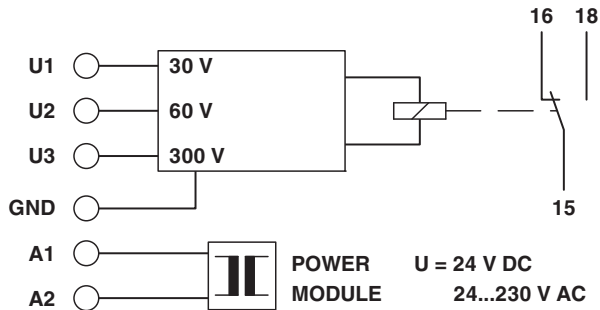

5 Safety notes



WARNING: Risk of electric shock

Never carry out work when voltage is present.

6 Structure

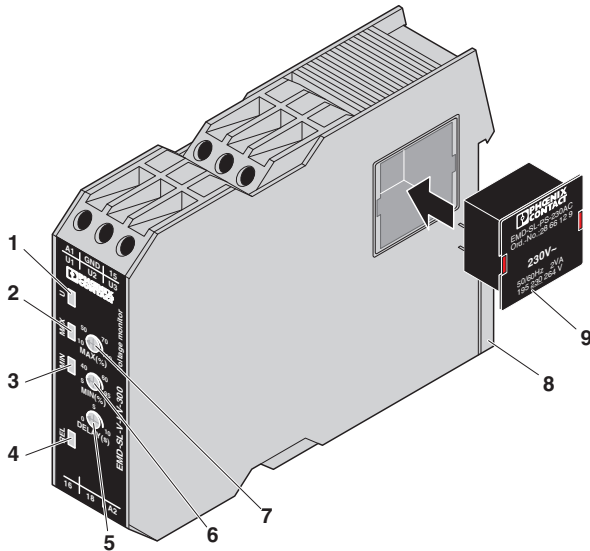

- 1 "U" LED: Supply voltage
- 2 "MAX" LED: Upper threshold value
- 3 "MIN" LED: Lower threshold value
- 4 "REL" LED: Output relay
- 5 "DELAY" potentiometer: Response delay
- 6 "MIN" potentiometer: Lower threshold value
- 7 "MAX" potentiometer: Upper threshold value
- 8 Universal snap-on foot for EN DIN rails
- 9 Power module

7 Power supply

The power module for power supply is supplied in a transport casing to prevent the connection legs from being bent.

To install the power module in the relay housing, remove the transport casing and position the power module in the recess in the side of the housing (ensure that it is the right way round). The red locking latches snap in with an audible click when the power module is securely positioned.

To remove the power module, press the two red locking latches together and pull out the power module.

8 Installation

**WARNING: Risk of electric shock**

Never carry out work when voltage is present.

The module can be snapped onto all 35 mm DIN rails according to EN 60715.

9 Diagnostics

The LEDs indicate the following error states:

"U" LED (Green)

- LED ON: Supply voltage present

"MIN" and "MAX" LEDs (Red)

- "MIN" LED flashes: Minimum value not reached, set delay time is running
- "MIN" LED ON: Minimum value not reached, delay time has elapsed
- Both LEDs flash alternately: Lower set threshold value is greater than upper threshold value

"REL" LED (Yellow)

- LED ON: Output relay has picked up
- LED OFF: Output relay has dropped out

10 Connection examples

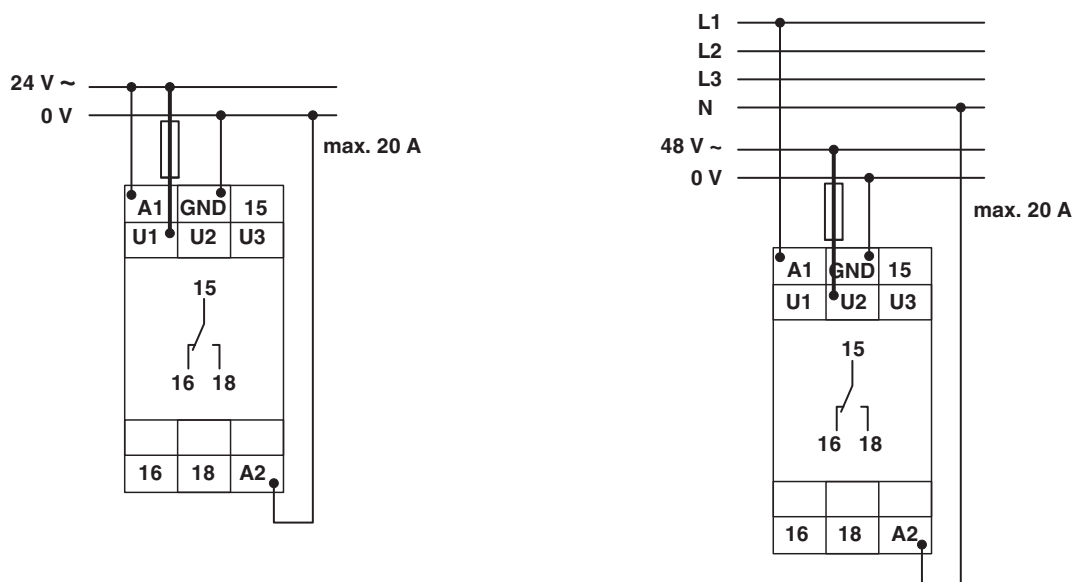

30 V (U1) measuring range with 24 V AC power module

60 V (U2) measuring range with 230 V AC power module

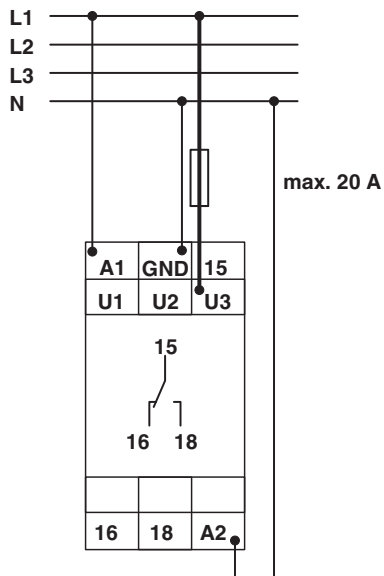

300 V (U3) measuring range with 230 V AC power module

11 Function

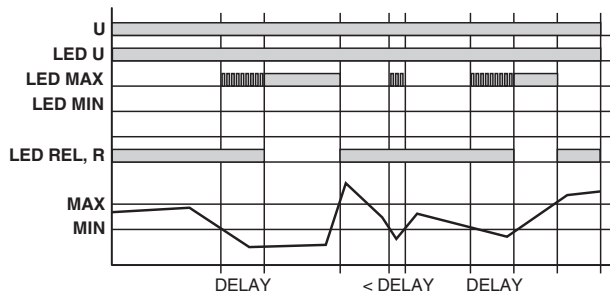

Undervoltage Monitoring (UNDER)

When supply voltage U is applied, output relay "R" picks up (yellow "REL" LED is ON).

If the measured voltage falls below the value set at the "MIN" controller, the set response delay (DELAY) starts (red "MIN" LED flashes). After the delay time has elapsed (red "MIN" LED is ON), output relay "R" drops out (yellow "REL" LED is OFF). If the measured voltage exceeds the value set at the "MAX" controller, output relay "R" picks up again (yellow "REL" LED is ON).

The "MIN" and "MAX" LEDs flash alternately if the minimum value selected for the measured voltage is greater than the maximum value.