

Compact Coaxial Connector

PSH Series

DDK Ltd.

OUTLINE

DDK's PSH compact miniature coaxial connector provides the optimal balance of performance and size. This surface mounted (SMT) RF connector with VSWR performance of 1.3 at DC to 3GHz and VSWR of 1.5 at 3 GHz to 6 GHz and a stacking height of 2.0mm or 2.5mm. This low cost connector is suitable for wireless LAN applications based upon IEEE 802-11a.

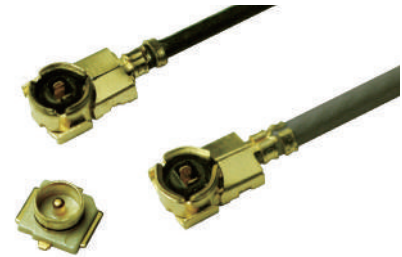

Frequency Range

DC to 6GHz

Characteristic Impedance

50 Ω

FEATURE

- Applicable frequency ranges DC to 3GHz or 3GHz to 6GHz
- Applicable 50 ohm coaxial cable sizes are ϕ 0.81mm ϕ 1.13mm ϕ 1.32mm and ϕ 1.37mm
- Compact and low profile mated height of 2.0mm or 2.5mm
- 30 mate/demate cycles
- Custom cable lengths available
- Applicable for IEEE 802.11a applications
- Tape and reel package
- RoHs Compliant

APPLICATIONS

- Wireless LAN, Portable PC, Mobile Phone, Measurement Equipments, Bluetooth.

SPECIFICATIONS

Characteristic Impedance	50 Ω
Rated Voltage	60VAC(r.m.s.)
Dielectric Withstanding Voltage	200V AC(r.m.s.) / 1 minute
Insulation Resistance	500M Ω Mim. at 100V DC
Contact Resistance	Contact : 20m Ω max. Outer conductor : 10m Ω max.
V.S.W.R.	1.3 max. at DC to 3GHz 1.5 max. at 3 to 6GHz
Operating Temperature	-40 ~ +85°C

Mating Height

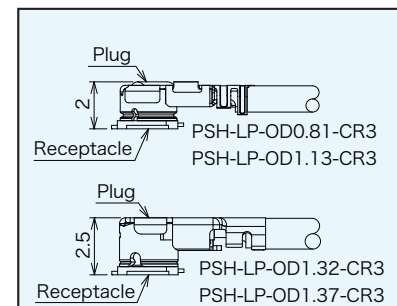

* The specifications are typical but may not apply to all connectors. Please check the specifications on each item with its drawing from us when you use.

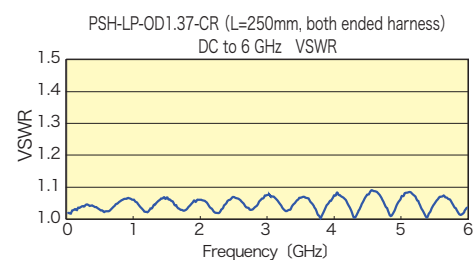
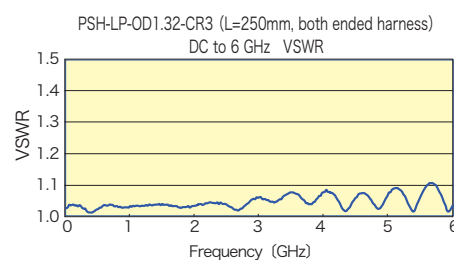
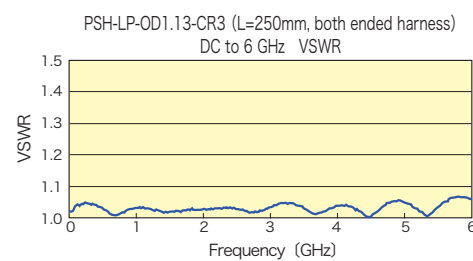
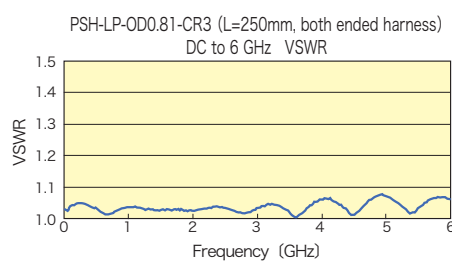

© Please acknowledge that the specification etc. of this catalog might change by the improvement etc. without notice.
Moreover, the characteristic and the specification of the published product are the reference values.
Please confirm the content with the latest delivery specifications when you use the product.

▶ Receptacle

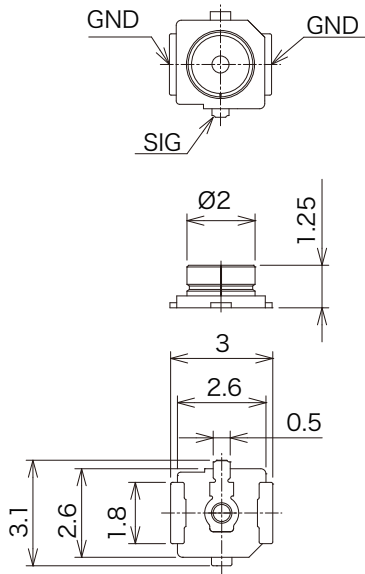

Part Number	Outer Conductor Finish	Quantity	
PSH-SR-PS-1000	Au	Reel Package	1000pcs./reel
PSH-SR-PS-5000	Au		5000pcs./reel

※ Tape and reel package

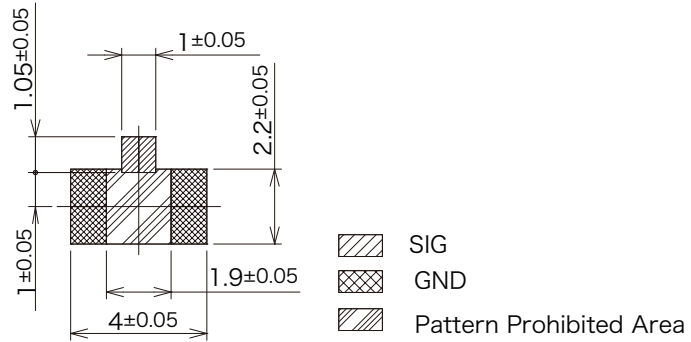

PCB Mounting Dimensions

MATERIAL/ FINISH



Item	Material / Finish
	Receptacle
Outer Conductor	Copper Alloy / Au Plating
Contact	Copper Alloy / Au Plating
Insulator	Thermoplastic Resin / Ivory

▶ Plug Cable Assmby

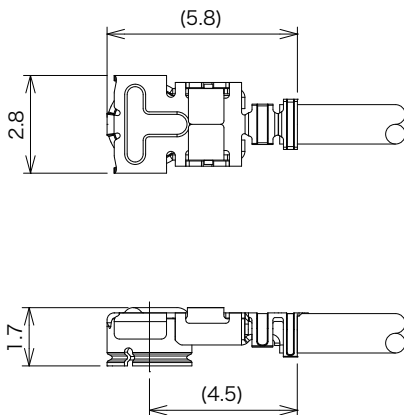

Applicable Cable	Part Number	Outer Conductor Finish
Dia. ϕ 1.13	PSH-LP-OD1.13-CR3	Au
Dia. ϕ 0.81	PSH-LP-OD0.81-CR3	Au

※ Plug connector is available in only cable assembly.

MATERIAL/ FINISH



Item	Material / Finish
	Plug
Outer Conductor	Copper Alloy / Au Plating
Contact	Copper Alloy / Au Plating
Insulator	Thermoplastic Resin / Black

Applicable Cable Size

Cable Size	Center Conductor	Insulator	Outer Conductor	Cable Dia.	Characteristic Impedance	Attenuation max.(dB/m)	
						3GHz	6GHz
O.D. ϕ 1.13	7/0.08 (AWG32)	ϕ 0.7	Single Braid	ϕ 1.13	50 Ω	4.0	5.7
	Ag Plating	FEP	Sn Plating	FEP			
O.D. ϕ 0.81	7/0.05 (AWG36)	ϕ 0.4	Single Braid	ϕ 0.81	50 Ω	6.2	9.4
	Ag Plating	FEP	Sn Plating	FEP			

© Please acknowledge that the specification etc. of this catalog might change by the improvement etc. without notice.
 Moreover, the characteristic and the specification of the published product are the reference values.
 Please confirm the content with the latest delivery specifications when you use the product.

▶ Plug Cable Assmly

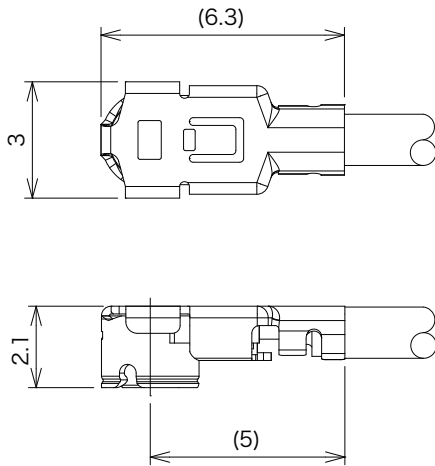

Applicable Cable	Part Number	Outer Conductor Finish
Dia. ϕ 1.32	PSH-LP-OD1.32-CR3	Au
Dia. ϕ 1.37	PSH-LP-OD1.37-CR3	Au

※ Plug connector is available in only cable assembly.

MATERIAL/ FINISH



Item	Material / Finish
	Plug
Outer Conductor	Copper Alloy / Au Plating
Contact	Copper Alloy / Au Plating
Insulator	Thermoplastic Resin / Black

Applicable Cable Size

Cable Size	Center Conductor	Insulator	Outer Conductor	Cable Dia.	Characteristic Impedance	Attenuation max.(dB/m)	
						3GHz	6GHz
O.D. ϕ 1.32	7/0.08 (AWG32)	ϕ 0.7	Double Braid	ϕ 1.32	50 Ω	3.7	5.4
	Ag Plating	FEP	Sn Plating	FEP			
O.D. ϕ 1.37	7/0.105 (AWG30)	ϕ 0.9	Single Braid	ϕ 1.37	50 Ω	3.0	4.7
	Ag Plating	FEP	Sn Plating	FEP			

▶ Adaptor (SMA plug to PSH jack)

DMP-SA-PSHJ

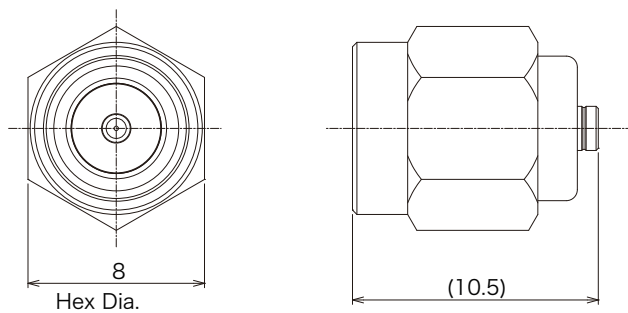

MATERIAL/ FINISH



Item	Material / Finish
	Adaptor
Outer Conductor	SUS(304)
Contact	Copper Alloy / Au Plating
Insulator	PTFE

© Please acknowledge that the specification etc. of this catalog might change by the improvement etc. without notice.
 Moreover, the characteristic and the specification of the published product are the reference values.
 Please confirm the content with the latest delivery specifications when you use the product.

▶ Harness

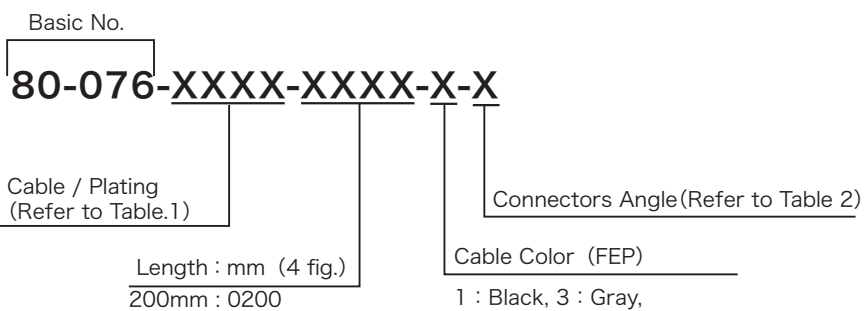
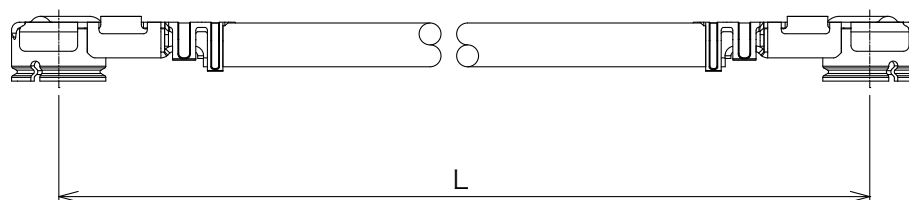

Table 1. Cable / Plating

No.	Cable O.D.	Outer conductor Plating
0001	φ 1.13	Au Plating
0003	φ 0.81	Au Plating
0005	φ 1.32	Au Plating
0007	φ 1.37	Au Plating

Table 3. Cable Length

Cable Length : L	Tolerance
25 ≤ L ≤ 200	±3
200 < L ≤ 500	±5
500 < L ≤ 1000	±10
1000 < L	±1.5%

Table 2. Connector Angle

Connector Angle 1	Connector Angle 2
Connector Angle 3	Connector Angle 4

© Please acknowledge that the specification etc. of this catalog might change by the improvement etc. without notice.
 Moreover, the characteristic and the specification of the published product are the reference values.
 Please confirm the content with the latest delivery specifications when you use the product.

▶ Instruction Manual

When mating the connector, please insert the connector along the center conductor.
 When unmating the connector, please pull off vertically by using below tool
 (No.357J-K8024-01) .
 Excessive torsional mating causes to be broken.

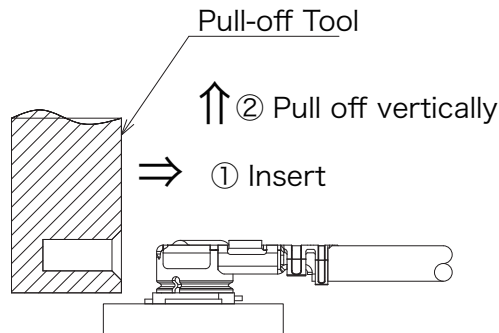

- Allowable cable load at mating
 Do not add the load more than right figure.

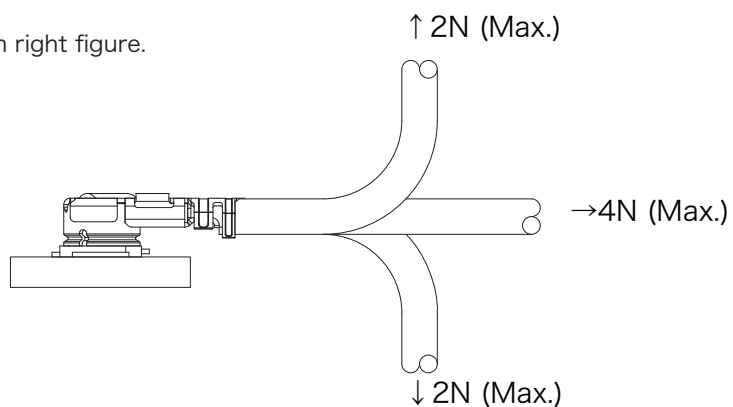

▶ Reflow Temperature Profile

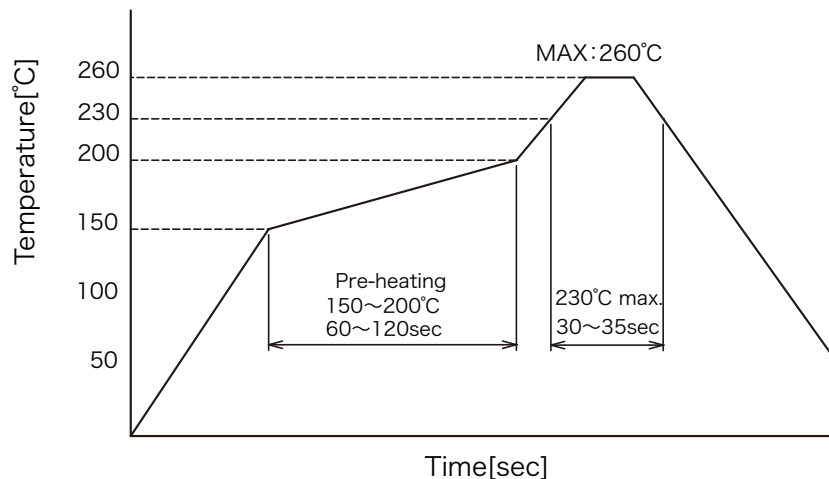

- ※ Above reflow temperature profile can be fluctuated by sort of the solder paste. Please test the soldering temperature beforehand.
- ※ The temperature is measured at the terminal area.
- ※ Reflow cycle is up to twice.

© Please acknowledge that the specification etc. of this catalog might change by the improvement etc. without notice.
 Moreover, the characteristic and the specification of the published product are the reference values.
 Please confirm the content with the latest delivery specifications when you use the product.