

Super-space-saving Signal Conditioners M3S-UNIT Series

RTD TRANSMITTER

(PC programmable)

Functions & Features

- Accepts direct input from an RTD and provides an isolated, linearized DC signal
- Linearization and burnout protection
- PC programmable
- Universal AC/DC power input
- High-density mounting
- Power and status indicator LED

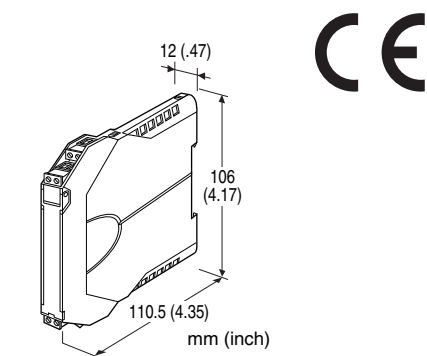

MODEL: M3SXR-[1][2]-[3][4]

ORDERING INFORMATION

- Code number: M3SXR-[1][2]-[3][4]
- Specify a code from below for each [1] through [4].
(e.g. M3SXR-4Z1-R/Q)
- Temperature range (e.g. 0 - 100°C)
- Output range (e.g. 4 - 20 mA DC)
- Specify the specification for option code /Q
(e.g. /C01)

[1] INPUT RTD

- 1:** JPt 100 (JIS'89)
(Usable range: -200 to +500°C, -328 to +932°F; min.span: 20°C, 36°F)
- 3:** Pt 100 (JIS'89)
(Usable range: -200 to +650°C, -328 to +1202°F; min.span: 20°C, 36°F)
- 4:** Pt 100 (JIS'97, IEC)
(Usable range: -200 to +850°C, -328 to +1562°F; min.span: 20°C, 36°F)
- 5:** Pt 50 Ω (JIS'81)
(Usable range: -200 to +649°C, -328 to +1200°F; min.span: 20°C, 36°F)
- 7:** Pt 1000
(Usable range: -200 to +850°C, -328 to +1562°F; min.span: 20°C, 36°F)
- 9:** Cu 10 @25°C
(Usable range: -50 to +250°C, -58 to +482°F; min.span: 20°C, 36°F)

0: Specify (Please provide a resistance table.)
(Configurator software is used to change the input type and range. Input code 7: Pt 1000 cannot be switched to/from other input types while its temperature range can be changed.)

[2] OUTPUT

Current

Z1: Range 0 - 20 mA DC

Voltage

V2: Range -10 - +10 V DC

V3: Range -5 - +5 V DC

(Configurator software is used to change output over the described range of the selected suffix code.

For changing between suffix codes, set the Output Range Selector on the side of unit before software adjustment.)

[3] POWER INPUT

AC Power

M2: 100 - 240 V AC (Operational voltage range 90 - 264 V, 47 - 66 Hz)

DC Power

R: 24 V DC

(Operational voltage range 24 V ±10 %, ripple 10 %p-p max.)

Universal

AD: 100 - 240 V AC / 24 - 240 V DC (universal)

(Operational voltage range 90 - 264 V AC, 47 - 66 Hz / 21.6 - 264 V DC, ripple 10 %p-p max.)

[4] OPTIONS

blank: none

/Q: With options (specify the specification)

SPECIFICATIONS OF OPTION: Q

COATING (For the detail, refer to M-System's web site.)

/C01: Silicone coating

/C02: Polyurethane coating

/C03: Rubber coating

RELATED PRODUCTS

- PC configurator software (model: M3SCFG)

Downloadable at M-System's web site.

A dedicated cable is required to connect the module to the PC. Please refer to the internet software download site or the users manual for the PC configurator for applicable cable types.

GENERAL SPECIFICATIONS

Construction: Small-sized front terminal structure
Connection: Euro type connector terminal
Applicable wire size: 0.2 to 2.5 mm², stripped length 8 mm
Housing material: Flame-resistant resin (gray)
Isolation: Input to output to power
Overrange output: -2 - +102 %
 (Negative current output is not available.)
Zero adjustment: -2 to +2 % (PC programming)
Span adjustment: 98 to 102 % (PC programming)
Burnout: Upscale standard; downscale or no burnout optional by programming
Linearization: Standard
Power LED: Green light turns on when the power is supplied.
Status indicator LED: Orange LED; Blinking patterns indicate different operating status of the transmitter.
Programming: Downloaded from PC
 Programmable features include:
 · Input type, number of wires and range
 · Output type and range
 · Zero and span adjustments
 · Burnout action
 · User's RTD table setting
 (max. 300 points, input resistance specified within 0 - 500 Ω, or 0 - 5 kΩ for Pt 1000)
 Refer to the instruction manual for details.
Configurator connection: 2.5 dia. miniature jack; RS-232-C level

INPUT SPECIFICATIONS

■ RTD
Number of wires: 2, 3 or 4 wires
Maximum leadwire resistance: 10 Ω per wire
Sensing current: ≤ 1.5 mA (≤ 0.1 5mA for Pt 1000)
 Note: Factory setting is 0 - 100°C if not otherwise specified

OUTPUT SPECIFICATIONS

■ DC Current
Output range: 0 - 20 mA DC
Conformance range: 0 - 20.4 mA DC
Minimum span: 1 mA
Offset: Lower range can be any specific value within the output range provided that the minimum span is maintained.
Load resistance: Output drive 11 V max.
 (e.g. 4 - 20 mA: 550 Ω [11 V ÷ 20 mA])
 If not specified, the output range is 4 - 20 mA DC.
 ■ DC Voltage
Code V2 (wide spans)
Output range: -10 - +10 V DC
Conformance range: -10.4 - +10.4 V DC

Minimum span: 1 V
Code V3 (narrow spans)
Output range: -5 - +5 V DC
Conformance range: -5.2 - +5.2 V DC
Minimum span: 0.5 V
Offset: Lower range can be any specific value within the output range provided that the minimum span is maintained.
Load resistance: Output drive 1 mA max.
 (e.g. 1 - 5 V: 5000 Ω [5 V ÷ 1 mA])
 If not specified, the output range is shown below.
 V2: 0 - 10 V DC
 V3: 1 - 5 V DC

INSTALLATION

Power consumption
 • AC:
 Approx. 2 VA at 100 V
 Approx. 3 VA at 200 V
 Approx. 4 VA at 264 V
 • DC:
 R: Approx. 0.5 W
 AD: Approx. 1 W
Operating temperature: -10 to +55°C (14 to 131°F)
Operating humidity: 30 to 90 %RH (non-condensing)
Mounting: DIN rail
Weight: 85 g (3.0 oz)

PERFORMANCE in percentage of span

Overall accuracy: Input accuracy + output accuracy
 Inversely proportional to the span.
 See CALCULATION EXAMPLES OF OVERALL ACURACY.
 • **Input accuracy:** (whichever is greater)
 ±0.1 % of FS or ±0.15°C (Pt and JPt)
 ±0.1 % of FS or ±1°C (Cu 10)
 • **Output accuracy:** ±0.04 % of max. output range
Temp. coefficient: ±0.015 %/°C (±0.008 %/°F) of max. span
Response time: ≤ 1 sec. (0 - 90 %)
Burnout response: ≤ 10 sec.
Line voltage effect: ±0.1 % over voltage range
Insulation resistance: ≥ 100 MΩ with 500 V DC
Dielectric strength: 2000 V AC @1 minute (input to output to power to ground)

CALCULATION EXAMPLES OF OVERALL ACCURACY

[Example] Pt 100, 0 - 100°C, Output Type -5 - +5 V, Output Range 1 - 5 V

Input Accuracy*¹ (0.15°C*²) ÷ Span (100°C) × 100 % +
 Max. Output Range (10 V) ÷ Span (4 V) × 0.04 % = 0.25 %

*1. Calculate the accuracy in °C.

*2. 100°C × 0.1 % = 0.1°C ≤ 0.15°C. 0.15°C is used as input accuracy value.

STANDARDS & APPROVALS

EU conformity:

EMC Directive

EMI EN 61000-6-4

EMS EN 61000-6-2

Low Voltage Directive

EN 61010-1

Installation Category II

Pollution Degree 2

Input or output to power: Reinforced insulation (300 V)

Input to output: Basic insulation (300 V)

RoHS Directive

EN 50581

EXTERNAL VIEW

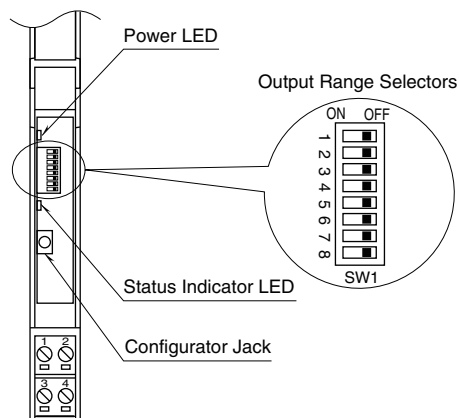

EXTERNAL DIMENSIONS & TERMINAL ASSIGNMENTS unit: mm (inch)

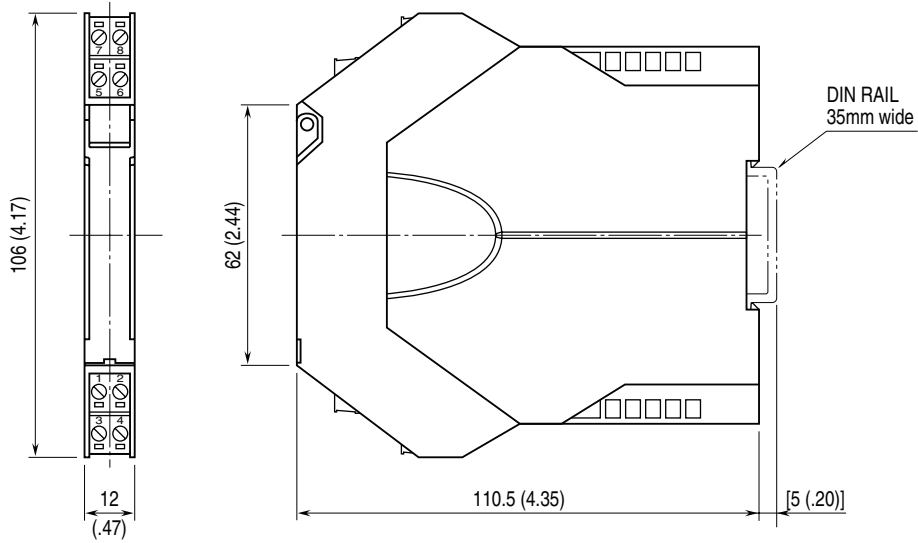

• When mounting, no extra space is needed between units.

SCHEMATIC CIRCUITRY & CONNECTION DIAGRAM

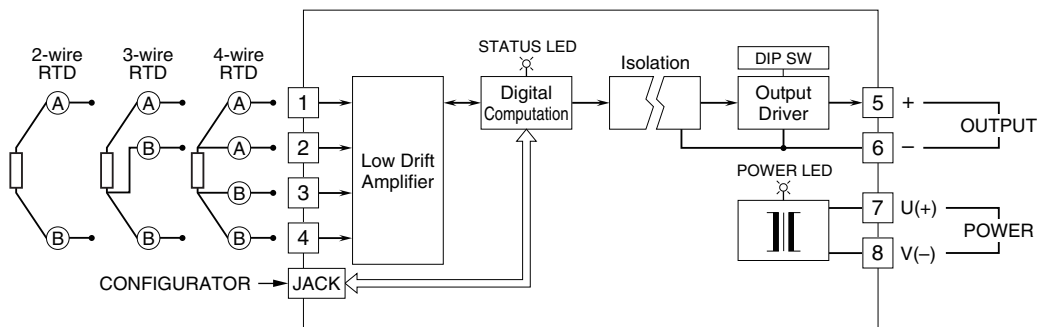

Specifications are subject to change without notice.