

ASL41S9 Data Sheet

5 ~ 4000 MHz High Linearity LNA MMIC

1. Product Overview

1.1 General Description

ASL41S9, a wideband linear low noise amplifier MMIC, has low noise and high linearity, being suitable for use in both receiver and transmitter of telecommunication systems about 500-1500 MHz. The amplifier is available in a SOT89 package and passes through the stringent DC, RF and reliability tests.



1.2 Features

- 17.5 dB Gain at 900 MHz
- 0.55 dB NF at 900 MHz
- 22.5 dBm P1dB at 900 MHz
- Current Adjustable: OIP3 at 900 MHz of 38 dBm @ 72mA, 43 dBm @ 90 mA
- MTTF > 100 Years
- Single Supply: +5 V

1.3 Applications

- Low Noise Amplifier for LTE, GSM, and CDMA
- Other Low Noise Application

1.4 Package Profile & RoHS Compliance

 <p>SOT89, 4.5x4.0 mm², surface mount</p>	 <p>RoHS-compliant</p>
---	---

2. Summary on Product Performances

2.1 Typical Performance

Supply voltage = +5 V, T_A = +25 °C, Z_O = 50 Ω.

Parameter	Typical						Unit
Frequency	700	900	1200	700	900	1200	MHz
Noise Figure	0.60	0.55	0.65	0.60	0.55	0.65	dB
Gain	19.4	17.5	15.3	19.5	17.6	15.4	dB
S11	-20.0	-18.0	-18.0	-20.0	-18.0	-18.0	dB
S22	-20.0	-20.0	-20.0	-20.0	-20.0	-20.0	dB
Output IP3 ¹⁾	37.5	38.0	36.5	40.0	43.0	38.0	dBm
Output P1dB	22.5	22.5	22.0	23.0	23.0	23.0	dBm
Current	72			90			mA
Device Voltage	+5			+5			V

1) OIP3 is measured with two tones at the output power of +5 dBm/tone separated by 1 MHz.

2.2 Product Specification

Supply voltage = +5 V, T_A = +25 °C, Z_O = 50 Ω.

Parameter	Min	Typ	Max	Unit
Frequency		900		MHz
Noise Figure		0.55	0.65	dB
Gain	16.5	17.5		dB
S11	-15	-18		dB
S22	-17	-20		dB
Output IP3	36	38		dBm
Output P1dB	21.5	22.5		dBm
Current	57	72	87	mA
Device Voltage		+5		V

2.3 Pin Configuration

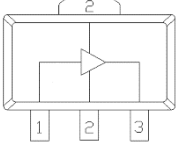
Pin	Description	Simplified Outline
1	RF_IN	
2	Ground	
3	RF_OUT & Bias	

2.4 Absolute Maximum Ratings

Parameters	Max. Ratings
Operation Case Temperature	-40 to +85 °C
Storage Temperature	-40 to +150 °C
Device Voltage	+5.5 V
Operation Junction Temperature	+150 °C
Input RF Power (CW, 50 Ω matched)	+25 dBm

2.5 Thermal Resistance

Symbol	Description	Typ	Unit
R _{th}	Thermal resistance from junction to lead	80	°C/W

2.6 ESD Classification & Moisture Sensitivity Level

ESD Classification

HBM	Class 1A	Voltage Level: 400 V
MM	Class A	Voltage Level: 50 V

CAUTION: Gallium Arsenide Integrated Circuits are sensitive to electrostatic discharge (ESD) and can be damaged by static electricity. Proper ESD control techniques should be used when handling these devices.

Moisture Sensitivity Level

MSL 3 at 260 °C reflow

(Intentionally Blanked)

3. Application: 600 ~ 1200 MHz (72 mA @ R1 = 5.1 kΩ)

3.1 Application Circuit & Evaluation Board

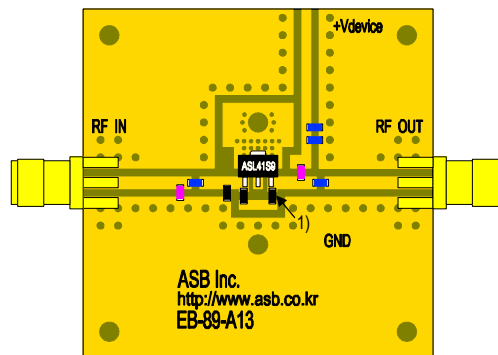
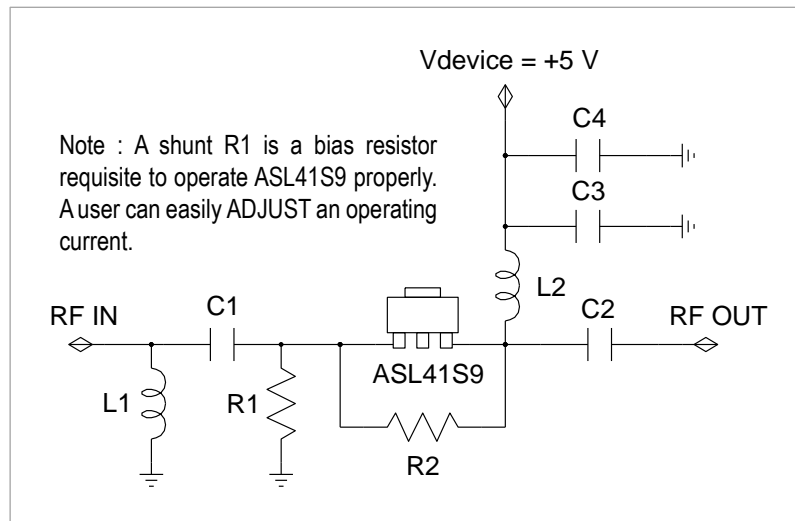

PCB Information	
Material	FR4
Thickness (mm)	0.8
Size (mm)	40x40
EB No.	EB-89-A13

Note:
1) Connect 0 Ω

Bill of Material

Symbol	Value	Size	Description	Manufacturer
ASL41S9	-	-	MMIC Amplifier	ASB
C1	8 pF	0603	DC blocking capacitor	Murata
C2	100 pF	0603	DC blocking capacitor	Murata
C3	100 pF	0603	Decoupling capacitor	Murata
C4	1 μF	0603	Decoupling capacitor	Murata
L1	15 nH	0603	Matching inductor	Murata
L2	27 nH	0603	RF choke inductor	Murata
R1	5.1 kΩ	0603	Current adjust resistor	Samsung
R2	51 kΩ	0603	Bias resistor	Samsung

3.2 Performance Table

Supply voltage = +5 V, $T_A = +25\text{ }^\circ\text{C}$, $Z_0 = 50\ \Omega$.

Parameter	Typical								Unit
Frequency	600	700	800	900	1000	1100	1200		MHz
Noise Figure	0.65	0.60	0.55	0.55	0.60	0.65	0.65		dB
Gain	20.4	19.4	18.4	17.5	16.6	15.9	15.3		dB
S11	-15	-20	-20	-18	-18	-18	-18		dB
S22	-18	-20	-20	-20	-20	-20	-20		dB
Output IP3 ¹⁾	36.0	37.5	37.5	38.0	38.0	37.5	36.5		dBm
Output P1dB	22.5	22.5	22.5	22.5	22.5	22.0	22.0		dBm
Current	72								mA
Device Voltage	+5								V

1) OIP3 is measured with two tones at the output power of +5 dBm/tone separated by 1 MHz.

3.3 Plot of S-parameter & Stability Factor

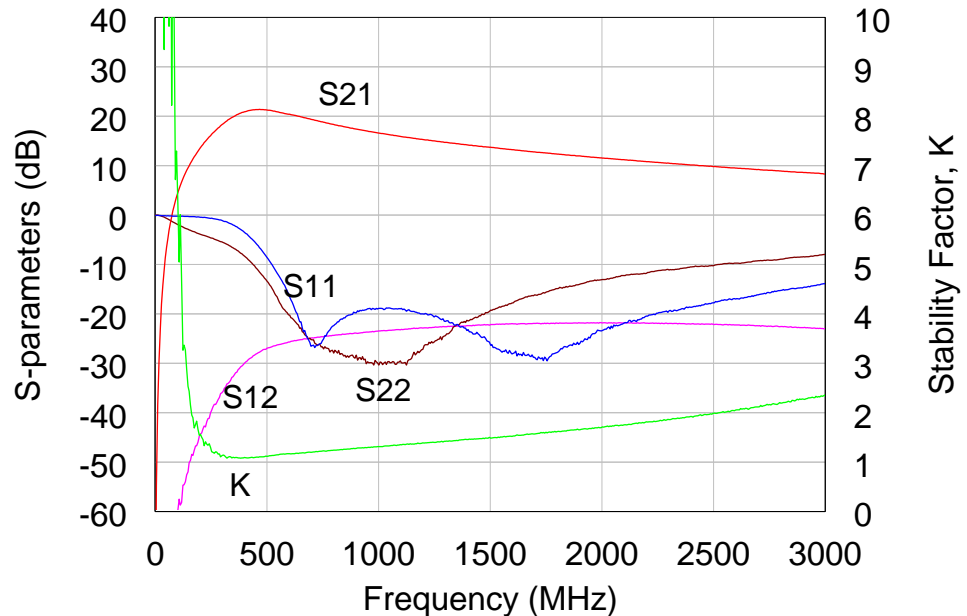

3.4 Plot of Noise Figure

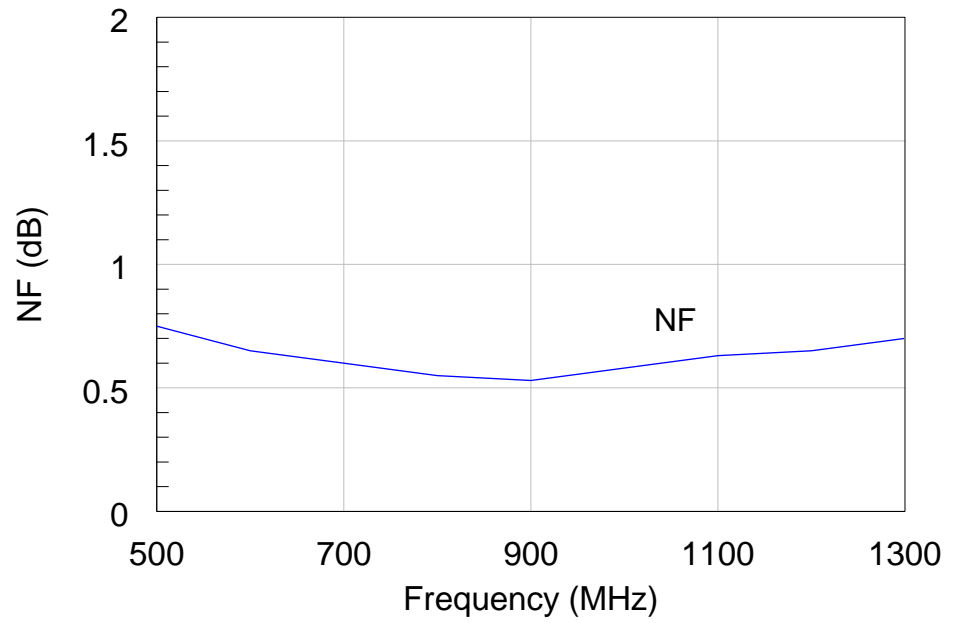

4. Application: 600 ~ 1200 MHz (90 mA @ R1 = 5.6 kΩ)

4.1 Application Circuit & Evaluation Board

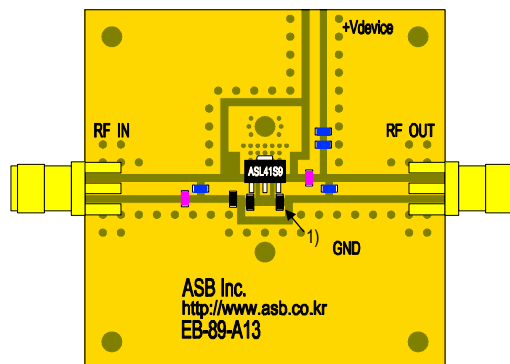
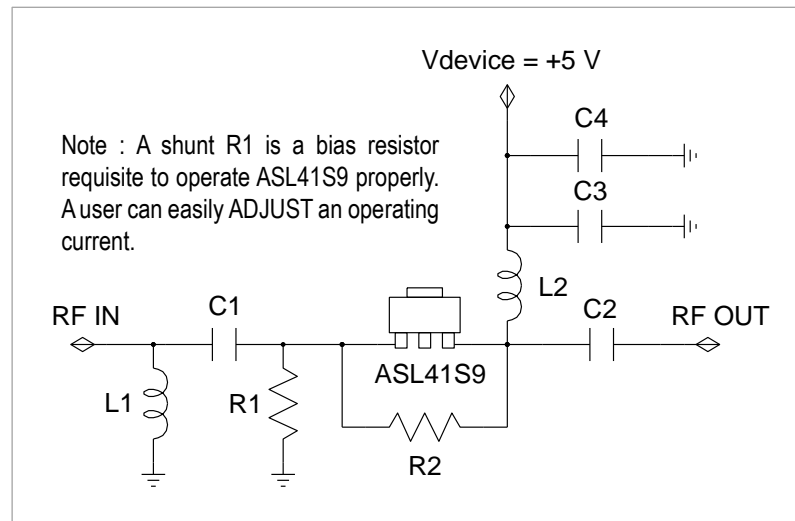

PCB Information	
Material	FR4
Thickness (mm)	0.8
Size (mm)	40x40
EB No.	EB-89-A13

Note:
1) Connect 0 Ω

Bill of Material

Symbol	Value	Size	Description	Manufacturer
ASL41S9	-	-	MMIC Amplifier	ASB
C1	8 pF	0603	DC blocking capacitor	Murata
C2	100 pF	0603	DC blocking capacitor	Murata
C3	100 pF	0603	Decoupling capacitor	Murata
C4	1 μF	0603	Decoupling capacitor	Murata
L1	15 nH	0603	Matching inductor	Murata
L2	27 nH	0603	RF choke inductor	Murata
R1	5.6 kΩ	0603	Current adjust resistor	Samsung
R2	51 kΩ	0603	Bias resistor	Samsung

4.2 Performance Table

Supply voltage = +5 V, $T_A = +25\text{ }^\circ\text{C}$, $Z_0 = 50\ \Omega$.

Parameter	Typical							Unit
Frequency	600	700	800	900	1000	1100	1200	MHz
Noise Figure	0.65	0.60	0.55	0.55	0.60	0.65	0.65	dB
Gain	20.5	19.5	18.5	17.6	16.7	16.0	15.4	dB
S11	-15	-20	-20	-18	-18	-18	-18	dB
S22	-18	-20	-20	-20	-20	-20	-20	dB
Output IP3 ¹⁾	38.0	40.0	42.0	43.0	42.0	40.0	38.0	dBm
Output P1dB	23.0	23.0	23.0	23.0	23.0	23.0	23.0	dBm
Current	90							mA
Device Voltage	+5							V

1) OIP3 is measured with two tones at the output power of +7dBm/tone separated by 1 MHz.

4.3 Plot of S-parameter & Stability Factor

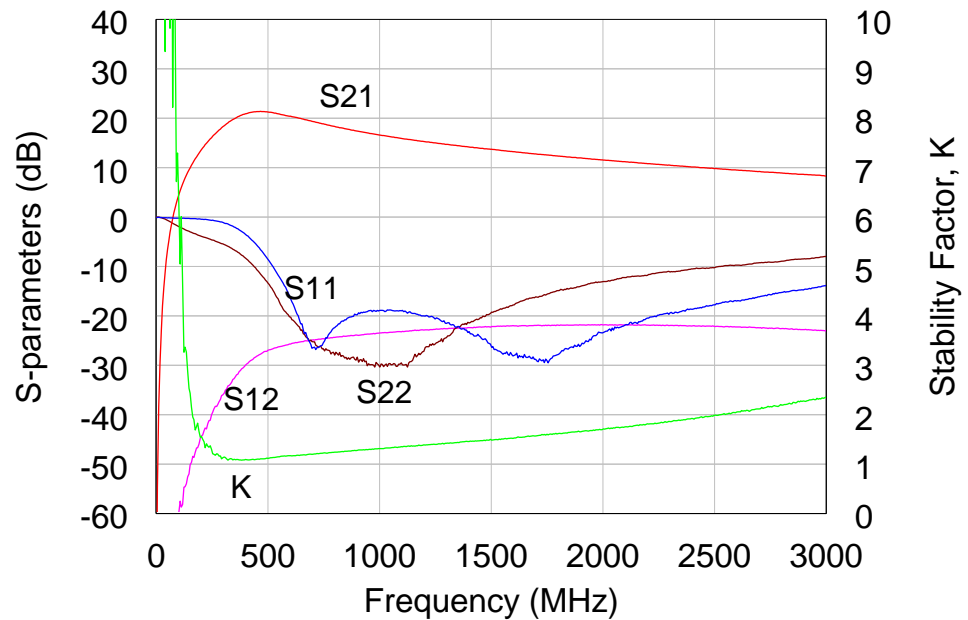

4.4 Plot of Noise Figure

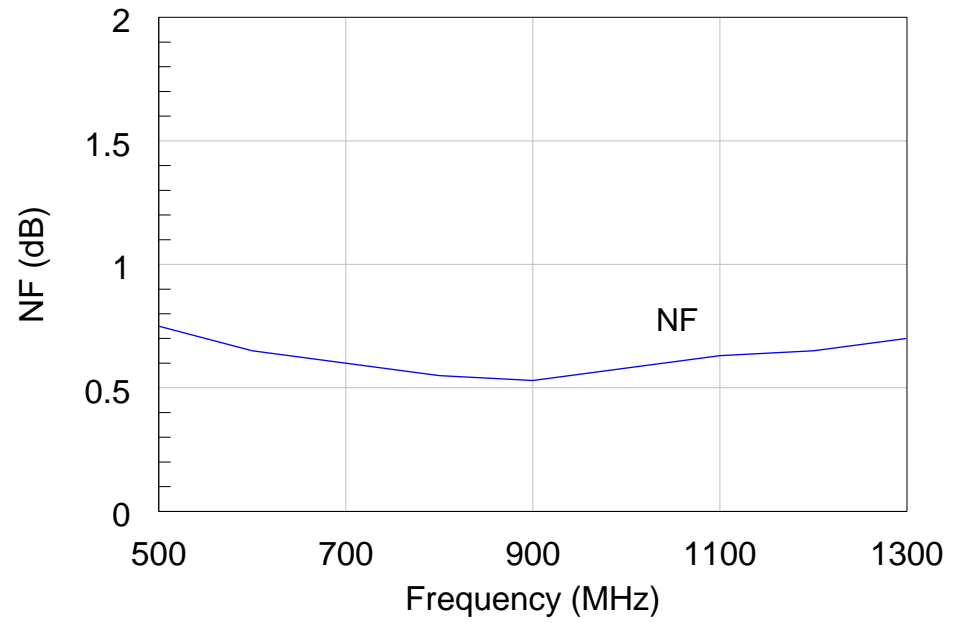

5. Package Outline (SOT89, 4.5x4.0x1.5 mm)

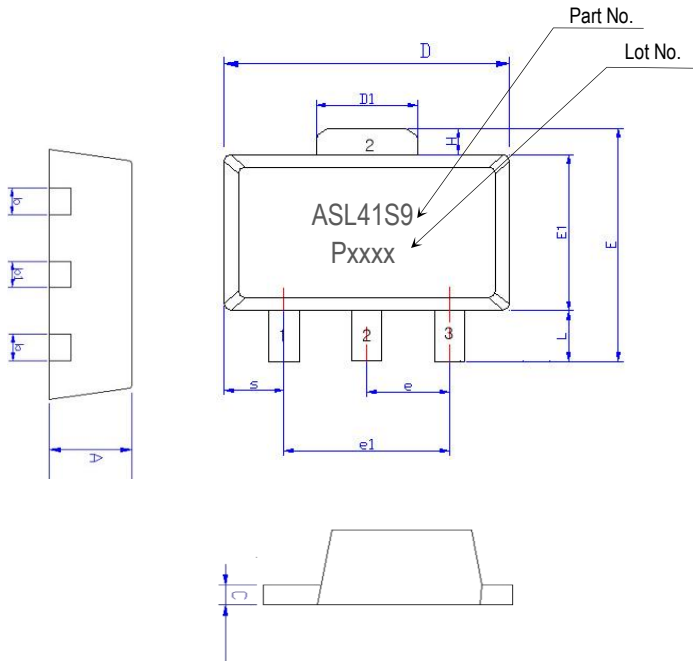

Symbols	Dimensions (In mm)		
	MIN	NOM	MAX
A	1.40	1.50	1.60
L	0.89	1.04	1.20
b	0.36	0.42	0.48
b1	0.41	0.47	0.53
C	0.38	0.40	0.43
D	4.40	4.50	4.60
D1	1.40	1.60	1.75
E	3.64	---	4.25
E1	2.40	2.50	2.60
e1	2.90	3.00	3.10
H	0.35	0.40	0.45
S	0.65	0.75	0.85
e	1.40	1.50	1.60

6. Surface Mount Recommendation (In mm)

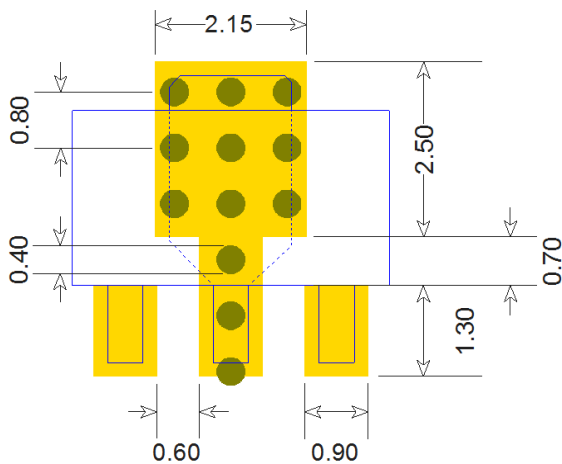

NOTE

1. The number and size of ground via holes in a circuit board are critical for thermal and RF grounding considerations.
2. We recommend that the ground via holes be placed on the bottom of the lead pin 2 and exposed pad of the device for better RF and thermal performance, as shown in the drawing at the left side.

7. Recommended Soldering Reflow Profile

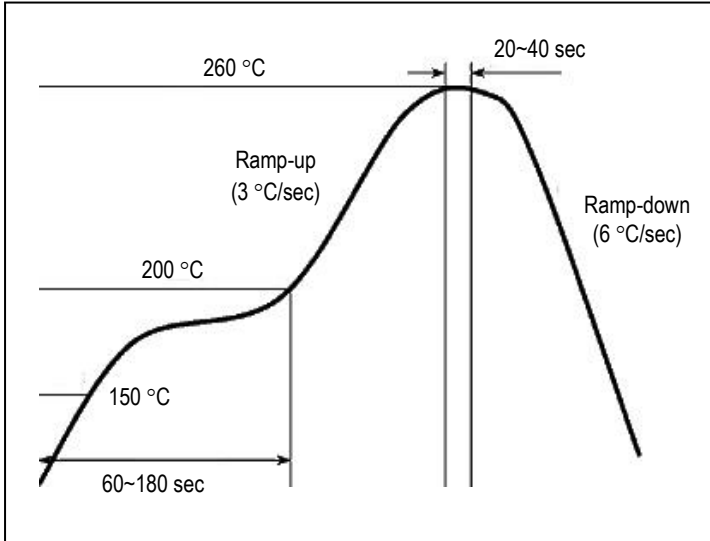

(End of Datasheet)

Copyright ©2013-2017 ASB Inc. All rights reserved. Datasheet subject to change without notice. ASB assumes no responsibility for any errors which may appear in this datasheet. No part of the datasheet may be copied or reproduced in any form or by any means without the prior written consent of ASB