

## Multiplex Transmission System

### MULTI-TRANSMISSION MODULE

#### Functions & Features

- Miniaturized, plug-in, socket-mounted version of the multiplex transmission system
- Analog, digital or pulse string signals transmitting via twisted-pair cable
- No master station required
- Easy expansion up to 256 modules (2000 points)

#### Typical Applications

- Input and output processing for computer systems and telemetering systems
- Complete system compatibility with DLA1 and other units, utilizing the same communication protocol

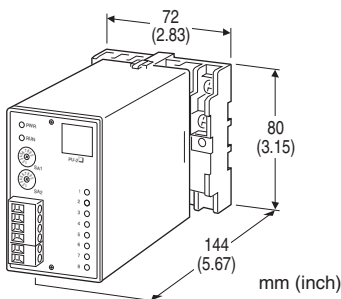

### MODEL: 22LA1-3[1]-[2]

#### ORDERING INFORMATION

- Code number: 22LA1-3[1]-[2]
- Specify a code from below for each [1] and [2] (e.g. 22LA1-3A4-K)

#### TRANSMISSION MEDIA

3: Twisted-pair cable for small-scale system

#### [1] I/O SECTION

- A1: Di 24 points (BCD)
- A2: Di 16 points (BCD)
- A4: Di 8 points
- C1: Do 24 points (BCD)
- C2: Do 16 points (BCD)
- C7: Do 8 points (relay)
- C8: Do 8 points (photo MOSFET relay)
- E5: Di 4 + Do 4 points (relay)
- E6: Di 4 + Do 4 points (photo MOSFET relay)
- G3: Ai 8 points
- G4: Ai 4 points
- M3: Ao 8 points

M4: Ao 4 points

P4: Pi 4 points

U4: Po 4 points

#### [2] POWER INPUT

##### AC Power

K: 85 - 132 V AC

(Operational voltage range 85 - 132 V, 47 - 66 Hz)

L: 170 - 264 V AC

(Operational voltage range 170 - 264 V, 47 - 66 Hz)

##### DC Power

S: 12 V DC

(Operational voltage range 12 V  $\pm$ 10 %, ripple 10 %p-p max.)

R: 24 V DC

(Operational voltage range 24 V  $\pm$ 10 %, ripple 10 %p-p max.)

#### GENERAL SPECIFICATIONS

**Construction:** Plug-in

##### Connection

**Power input:** M3.5 screw terminals

**Field I/O:** M3.5 screw terminals or 26-pin connector

**Transmission:** Euro type connector terminal

**Housing material:** Flame-resistant resin (black)

**Isolation:** I/O to transmission to reset (provided only for pulse I/O type) to power

**Terminator:** Incorporated (remove jumper pin with those modules not located at the end of transmission line)

**Power indicator:** Red LED turns ON in normal conditions; OFF when the voltage level becomes low.

**RUN indicator:** Red LED turns ON when the selfdiagnosis proves normal, OFF in an abnormality.

■ **RUN Output:** Contact opens when the self-diagnosis detects an abnormality.

125 V AC @ 0.5 A ( $\cos \phi = 1$ )

30 V DC @ 0.5 A (resistive load)

**Maximum switching voltage:** 250 V AC or 125 V DC

**Maximum switching power:** 62.5 VA or 60 W

**Minimum load:** 10 mV DC @ 1 mA

**Mechanical life:**  $5 \times 10^7$  cycles (rate 300/min.)  $10^8$  cycles (rate 180/min.)

##### Self-diagnosis

**Communication:** The receiver modules detect loss of communication and wire break.

**CPU:** Watch-dog timer

**Memory:** Sum check

**Power voltage:** Detects when the voltage supply to the CPU drops.

#### COMMUNICATION

**Communication:** 2-wire, half-duplex

**Transmission:** conform to RS-422, EIA

**Transmission speed:** 125 kbps  
**Data encoding:** SDLC  
**Control procedure:** NRZ  
**Protocol:** SIN-NET (M-System's)  
**Error check:** CRC  
**Cable:** CPEV-0.9 dia.  
**Transmission distance:** 500 meters

## INSTALLATION

### Power consumption

- AC:** Approx. 5 VA
- DC:** 24 V or 12 V  $\pm 10\%$  (ripple 10 %p-p max.) approx. 4.4 W (180 mA with 24 V) with 8-point relays at the maximum load

**Operating temperature:** -5 to + 50°C (23 to 122°F)  
**Operating humidity:** 30 to 90 %RH (non-condensing)  
**Atmosphere:** No corrosive gas or heavy dust  
**Mounting:** Surface or DIN rail  
**Weight:** 400 g (0.88 lbs)

## PERFORMANCE

**Permissible power failure duration:**  $\leq 10$  msec.  
**Insulation resistance:**  $\geq 100$  M $\Omega$  with 500 V DC  
**Dielectric strength:** 500 V AC @ 1 minute  
(I/O to transmission to reset\*)  
1500 V AC @ 1 minute  
(power to I/O or transmission or reset\*)  
1500 V AC @1 minute (FG to each section)  
\*Reset terminals are provided only for pulse string I/O type.

## DESCRIPTIONS

### ■ RUN Output (LED) Operation

#### Input unit

The LED for the Input Units (A1, A2, A4, G3, G4 and P4) turns ON when the network is on-line. When there is an abnormality in the network, the LED turns OFF. The network is reconfigured after an abnormality.

#### Output unit

The LED for the Output Units (C1, C2, C7, C8, M3, M4 and U4) turns ON when the network is on-line and the unit receives data from the corresponding Input Unit.

When there is an abnormality in the network or there is no data receiving, the LED turns OFF.

**When the I/O Units are connected via the 22LS1 (DLS),** once the LED turns ON, it remains ON regardless of the state of Input Unit or the leased circuit.

**When the Output Unit is connected to the DLC** (for setting data from the DLC), the LED turns ON once the Output Unit receives normal data, and remains ON even when there is no data update.

#### I/O Unit

The LED's operating conditions for the I/O Unit (E5 and E6) are combined ones of Input Unit and Output Unit.

Caution: When the network is reconfigured e.g. by noise interference, the RUN LED and output for all units on the network turn briefly OFF until they are turned ON after the reconfiguration is complete.

### ■ Station Number (Address)

**A) 1 input unit and X output units:** Match the address for input and output modules. The input data can be output at several modules.

**B) I/O mixed modules:** Set an even number and a consecutive number for the 2 corresponding modules.

C) **Computer interface:** Set address numbers to correspond with the computer as I/O module.

■ **Transmission Time**

Integrate all the transmission time for each process input (or I/O-mixed) module in the system.

- Contact input, BCD, 16 points (A2) 1.5 msec.
- Contact input 8 points (A4) 1.5 msec.
- Contact I/O each 4 points (E5, E6) 1.5 msec.
- Analog input 8 points (G3) 12.0 msec.
- Analog input 4 points (G4) 6.0 msec.
- Pulse input 4 points (P4) 6.0 msec.

An analog module does not transmit all its signals in serial but does 1 point per each cycle. For example, when 1 contact input module (8 points) and 1 analog input module (4 points) are connected, 8 point contact signal and 1 point analog signal are transmitted in turn. One cycle time is therefore calculated as:

$$4 \text{ points} \times 1.5 \text{ msec.} + 6 \text{ msec.} = 12 \text{ msec.}$$

This method is beneficial for giving a priority to contact signals which vary rapidly.

■ **Transmission line configuration**

The multi-drop transmission line containing 22LA1 and DLx units should meet the following conditions.  
Contact M-System's sales office or representatives when designing.

A) **10 kilometers** at maximum in total system.

B) **Line consists only of 22LA1 modules:** one multitransmission line can contain at the maximum of 16 units within the total distance of 500 m.

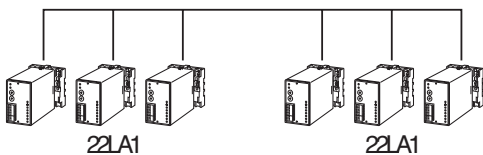

C) **22LA1 modules plus link adapter (model: DAL4):** DAL4 units can expand the total distance. (8 DAL4 units max.)

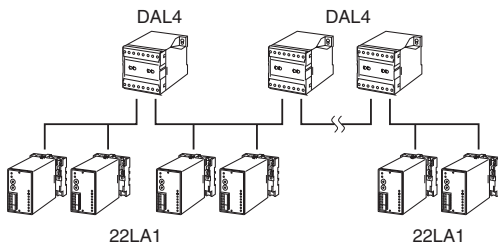

D) **22LA1 modules plus DLx units:** the total distance of a section consists of 22LA1 modules is less than 500 meters. The 22LA1 modules can be connected to DLx units via a DLx-7 unit. (Eight DLx-7 units max.)

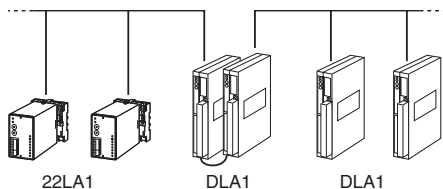

## EXTERNAL VIEW

### ■ 22LA1-3A1, -3C1

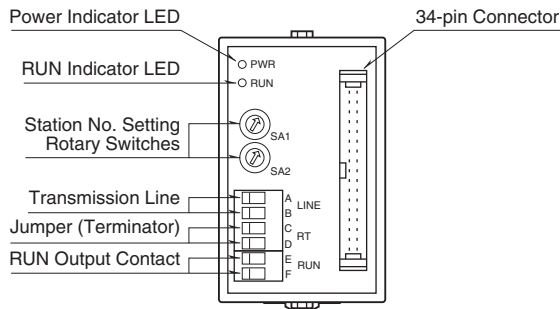

#### •Pin Assignments

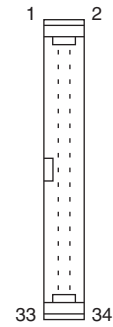

### ■ 22LA1-3A2, -3C2

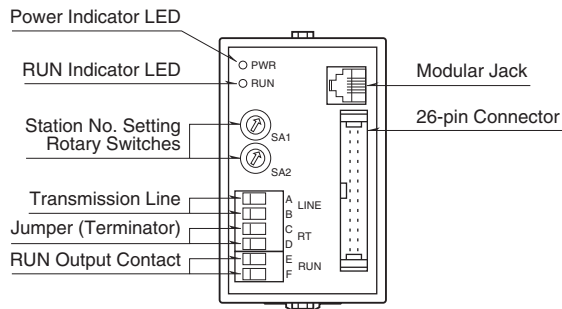

#### •Pin Assignments

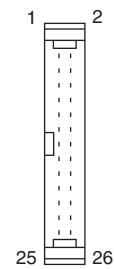

### ■ STANDARD TYPE

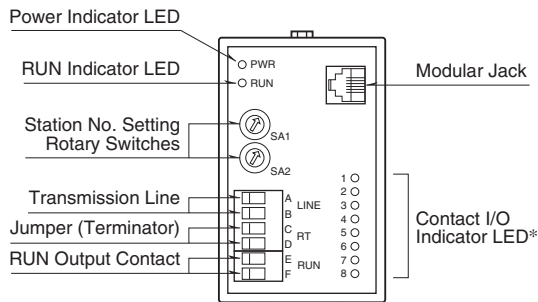

\*Deleted with analog I/O modules.  
LED5 through 8 deleted with the 22LA1-3P4 or -3U4.

## EXTERNAL DIMENSIONS & TERMINAL ASSIGNMENTS unit: mm (inch)

### ■ 22LA1-3A1, -3C1

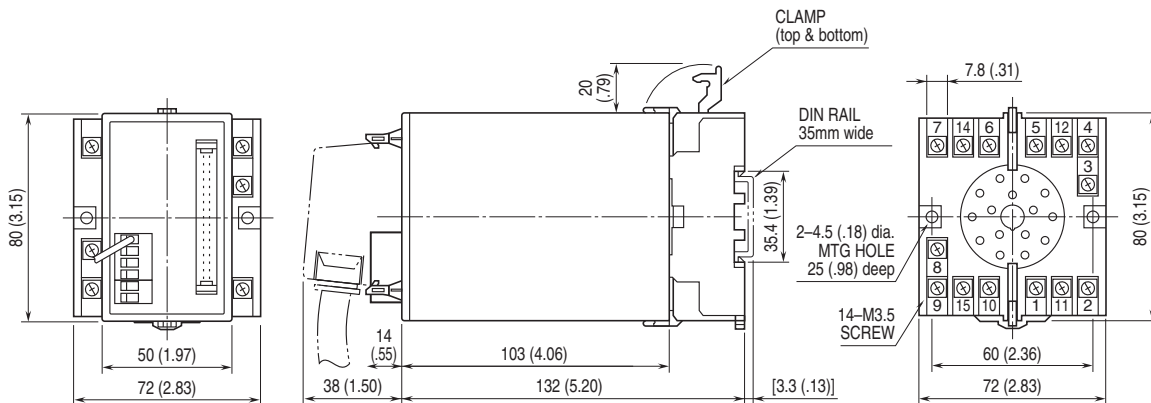

•When mounting, no extra space is needed between units.

## ■ 22LA1-3A2, -3C2

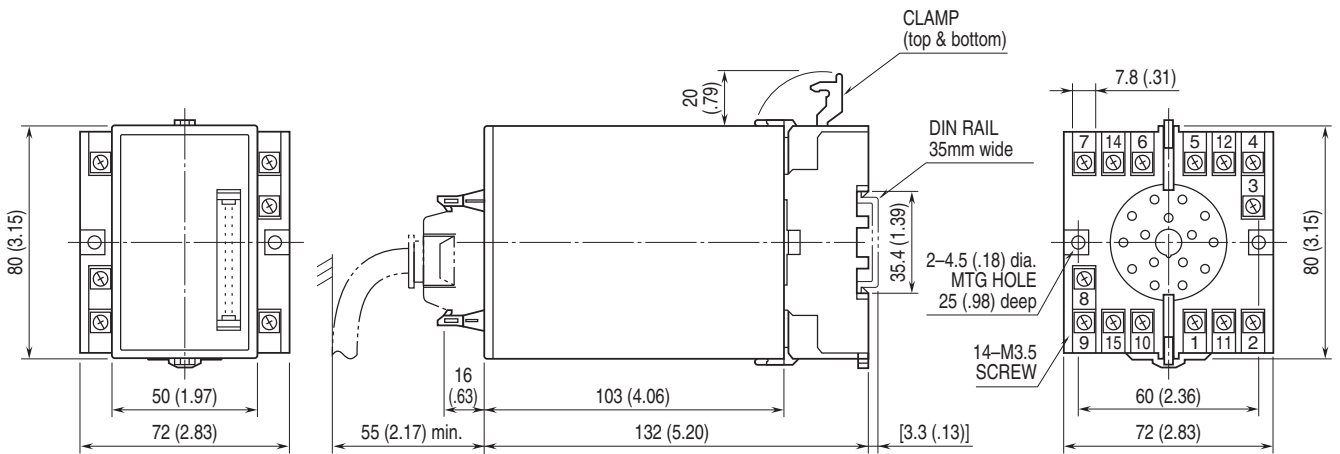

•When mounting, no extra space is needed between units.

## ■ STANDARD TYPE

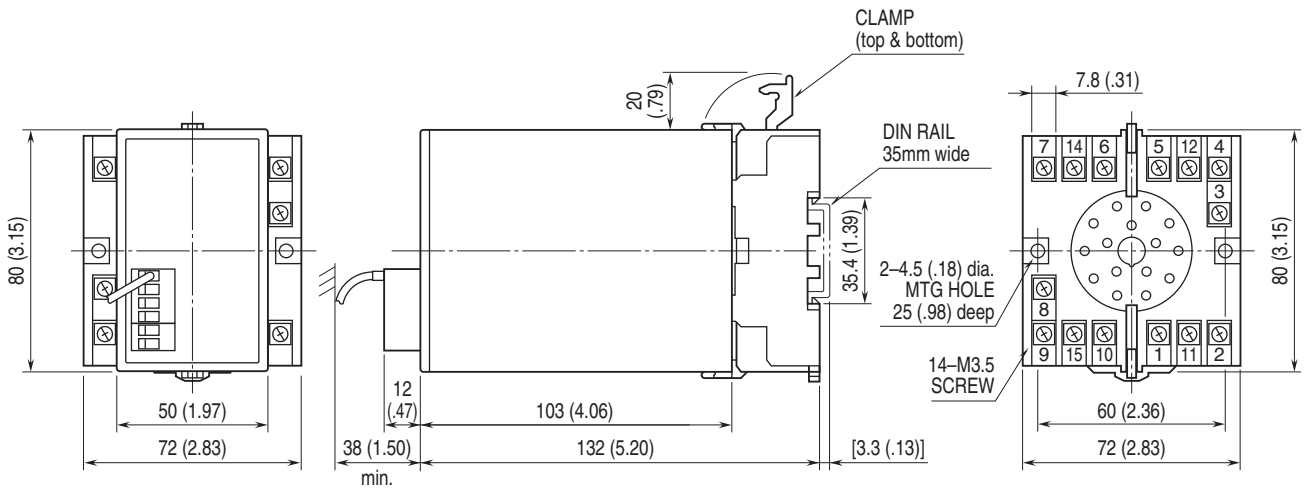

•When mounting, no extra space is needed between units.

## SCHEMATIC CIRCUITRY & CONNECTION DIAGRAM

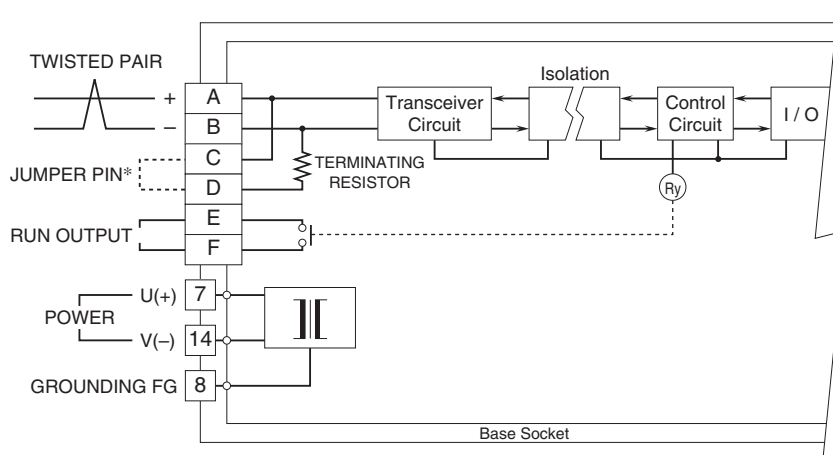

\*When the unit is located at the end of transmission line via twisted-pair cable (= no cross-wiring), short across the terminals C – D with the jumper pin (or wire) provided with the unit. Remove the jumper pin for the one not located at the end.

## CONTACT INPUT MODULE (BCD)

**MODEL: 22LA1-3A1-[1]**

### ORDERING INFORMATION

- Code number: 22LA1-3A1-[1]
- Specify a code from power input options for [1]  
(e.g. 22LA1-3A1-K)

### GENERAL SPECIFICATIONS

**Input connector:** 34-pin connector  
(OMRON XG4A-3434)

**Usable connector type:** OMRON XG4M-3430-T,  
XG5M-343x-N)

**Usable cover type:** OMRON XG5S-3422

The special cable (model: MCN34), Connector Terminal Block (model: CNT) are available.

### INPUT SPECIFICATIONS

**Input:** TTL level (5V-CMOS level); open collector or dry contact (saturation voltage  $\leq 1$  V, sink current 1 mA); negative logic

■ **Starion No.:** Match the number of input and output modules

### PERFORMANCE

**Multi-transmission time:** 1.5 msec.  
**Input read time:** 50 msec.

### CONNECTOR PIN ASSIGNMENT

PIN NO.	ASSIGNMENT	PIN NO.	ASSIGNMENT
1	$1 \times 10^0$ (B <sup>0</sup> )	21	$1 \times 10^5$ (B <sup>20</sup> )
2	$2 \times 10^0$ (B <sup>1</sup> )	22	$2 \times 10^5$ (B <sup>21</sup> )
3	$4 \times 10^0$ (B <sup>2</sup> )	23	$4 \times 10^5$ (B <sup>22</sup> )
4	$8 \times 10^0$ (B <sup>3</sup> )	24	$8 \times 10^5$ (B <sup>23</sup> )
5	$1 \times 10^1$ (B <sup>4</sup> )	25	COM
6	$2 \times 10^1$ (B <sup>5</sup> )	26	COM
7	$4 \times 10^1$ (B <sup>6</sup> )	27	No connection
8	$8 \times 10^1$ (B <sup>7</sup> )	28	No connection
9	$1 \times 10^2$ (B <sup>8</sup> )	29	No connection
10	$2 \times 10^2$ (B <sup>9</sup> )	30	No connection
11	$4 \times 10^2$ (B <sup>10</sup> )	31	No connection
12	$8 \times 10^2$ (B <sup>11</sup> )	32	No connection
13	$1 \times 10^3$ (B <sup>12</sup> )	33	No connection
14	$2 \times 10^3$ (B <sup>13</sup> )	34	No connection
15	$4 \times 10^3$ (B <sup>14</sup> )		
16	$8 \times 10^3$ (B <sup>15</sup> )		
17	$1 \times 10^4$ (B <sup>16</sup> )		
18	$2 \times 10^4$ (B <sup>17</sup> )		
19	$4 \times 10^4$ (B <sup>18</sup> )		
20	$8 \times 10^4$ (B <sup>19</sup> )		

B<sup>0</sup> – B<sup>23</sup> are inputs.

### TERMINAL CONNECTION (INPUT)

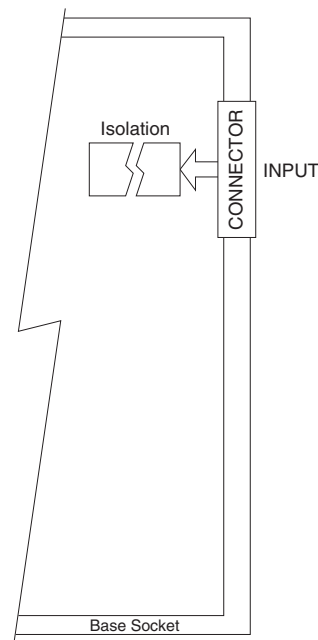

## CONTACT INPUT MODULE (BCD)

**MODEL: 22LA1-3A2-[1]**

### ORDERING INFORMATION

- Code number: 22LA1-3A2-[1]

Specify a code from power input options for [1]  
(e.g. 22LA1-3A2-K)

### GENERAL SPECIFICATIONS

**Input connector:** 26-pin connector (OMRON XG4A-2934)  
**Usable connector type:** OMRON XG4M-2630-T, XG5M-263x-N)  
**Usable cover type:** OMRON XG5S-2612  
 The special cable (model: MCN26), Connector Terminal Block (model: CNT) are available.

### INPUT SPECIFICATIONS

**Input:** TTL level (5V-CMOS level); open collector or dry contact (saturation voltage  $\leq 1$  V, sink current 1 mA); negative logic

■ **Starion No.:** Match the number of input and output modules

### PERFORMANCE

**Multi-transmission time:** 1.5 msec.  
**Input read time:** 50 msec.

### CONNECTOR PIN ASSIGNMENT

PIN NO.	ASSIGNMENT	PIN NO.	ASSIGNMENT
1	$1 \times 10^0$ (B <sup>0</sup> )	17	COM
2	$2 \times 10^0$ (B <sup>1</sup> )	18	COM
3	$4 \times 10^0$ (B <sup>2</sup> )	19	No connection
4	$8 \times 10^0$ (B <sup>3</sup> )	20	No connection
5	$1 \times 10^1$ (B <sup>4</sup> )	21	No connection
6	$2 \times 10^1$ (B <sup>5</sup> )	22	No connection
7	$4 \times 10^1$ (B <sup>6</sup> )	23	COM
8	$8 \times 10^1$ (B <sup>7</sup> )	24	COM
9	$1 \times 10^2$ (B <sup>8</sup> )	25	No connection
10	$2 \times 10^2$ (B <sup>9</sup> )	26	No connection
11	$4 \times 10^2$ (B <sup>10</sup> )		
12	$8 \times 10^2$ (B <sup>11</sup> )		
13	$1 \times 10^3$ (B <sup>12</sup> )		
14	$2 \times 10^3$ (B <sup>13</sup> )		
15	$4 \times 10^3$ (B <sup>14</sup> )		
16	$8 \times 10^3$ (B <sup>15</sup> )		

B<sup>0</sup> – B<sup>15</sup> are inputs.

### TERMINAL CONNECTION (INPUT)

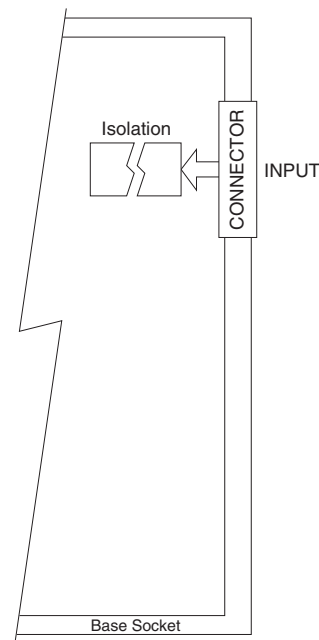

## CONTACT INPUT MODULE

(Di 8 points)

### MODEL: 22LA1-3A4-[1]

#### ORDERING INFORMATION

- Code number: 22LA1-3A4-[1]

Specify a code from power input options for [1]

(e.g. 22LA1-3A4-K)

#### INPUT SPECIFICATIONS

**Input:** Dry contact, 8 points

**Commons:** All negatives

**Sensing:** 12 V DC

≥ 3 mA at ON

≤ 1 mA at OFF

■ **Starion No.:** Match the number of input and output modules

#### PERFORMANCE

**Multi-transmission time:** 1.5 msec.

**Input read time:** 5 msec. per 8 points

#### TERMINAL CONNECTION (INPUT)

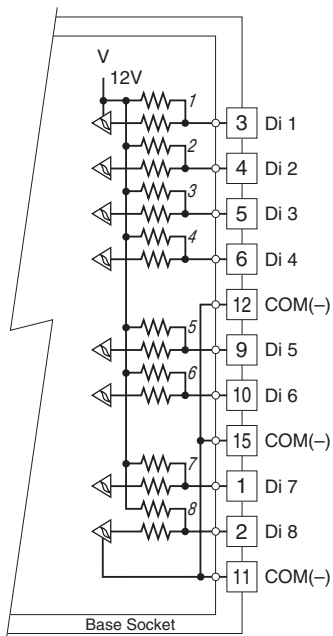

*Italic figures indicate LED No. on the front panel.*



## CONTACT OUTPUT MODULE (BCD)

**MODEL: 22LA1-3C1-[1]**

### ORDERING INFORMATION

• Code number: 22LA1-3C1-[1]  
Specify a code from power input options for [1]  
(e.g. 22LA1-3C1-K)

### GENERAL SPECIFICATIONS

**Output connector:** 34-pin connector  
(OMRON XG4A-3434)  
**Usable connector type:** OMRON XG4M-3430-T,  
XG5M-343x-N)  
**Usable cover type:** OMRON XG5S-3422  
The special cable (model: MCN34), Connector Terminal  
Block (model: CNT) are available.  
When driving an inductive load, external protection is  
recommended.

### INPUT SPECIFICATIONS

**Hold Input:** TTL level (5V-CMOS level); open collector or dry  
contact (saturation voltage  $\leq 1$  V, sink current 1 mA);  
negative logic

### OUTPUT SPECIFICATIONS

**Output:** Open collector  
**Maximum collector-emitter voltage:** 30 V DC  
**Maximum collector current:** 30 mA  
**Saturation voltage:**  $\leq 1.1$  V; negative logic  
**DAV output (Data available):** Same level as for the output  
code; negative logic  
■ **Starion No.:** Match the number of input and output  
modules

### PERFORMANCE

**Output time:**  $\leq 20$  msec.

## CONNECTOR PIN ASSIGNMENT

PIN NO.	ASSIGNMENT	PIN NO.	ASSIGNMENT
1	$1 \times 10^0$ (B <sup>0</sup> )	21	$1 \times 10^5$ (B <sup>20</sup> )
2	$2 \times 10^0$ (B <sup>1</sup> )	22	$2 \times 10^5$ (B <sup>21</sup> )
3	$4 \times 10^0$ (B <sup>2</sup> )	23	$4 \times 10^5$ (B <sup>22</sup> )
4	$8 \times 10^0$ (B <sup>3</sup> )	24	$8 \times 10^5$ (B <sup>23</sup> )
5	$1 \times 10^1$ (B <sup>4</sup> )	25	COM
6	$2 \times 10^1$ (B <sup>5</sup> )	26	COM
7	$4 \times 10^1$ (B <sup>6</sup> )	27	DAV
8	$8 \times 10^1$ (B <sup>7</sup> )	28	HOLD
9	$1 \times 10^2$ (B <sup>8</sup> )	29	No connection
10	$2 \times 10^2$ (B <sup>9</sup> )	30	No connection
11	$4 \times 10^2$ (B <sup>10</sup> )	31	No connection
12	$8 \times 10^2$ (B <sup>11</sup> )	32	No connection
13	$1 \times 10^3$ (B <sup>12</sup> )	33	No connection
14	$2 \times 10^3$ (B <sup>13</sup> )	34	No connection
15	$4 \times 10^3$ (B <sup>14</sup> )		
16	$8 \times 10^3$ (B <sup>15</sup> )		
17	$1 \times 10^4$ (B <sup>16</sup> )		
18	$2 \times 10^4$ (B <sup>17</sup> )		
19	$4 \times 10^4$ (B <sup>18</sup> )		
20	$8 \times 10^4$ (B <sup>19</sup> )		

B<sup>0</sup> – B<sup>23</sup> are inputs, DAV is an output, and HOLD is an input.

## TERMINAL CONNECTION (OUTPUT)

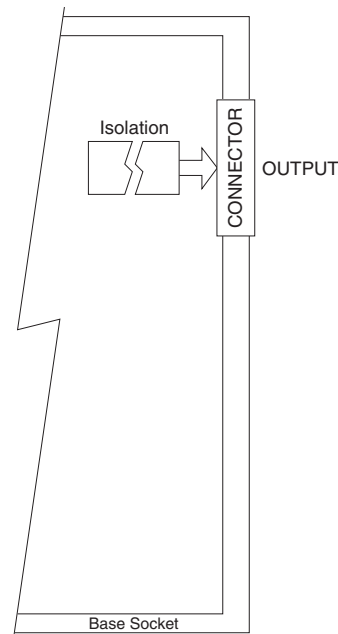

**TIMING CHART**

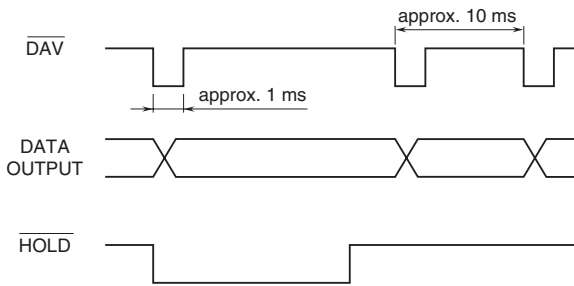

When the HOLD input signal is valid ("L"), the DAV output is not provided and the data output is held at the value before that.

## CONTACT OUTPUT MODULE (BCD)

**MODEL: 22LA1-3C2-[1]**

### ORDERING INFORMATION

• Code number: 22LA1-3C2-[1]  
Specify a code from power input options for [1]  
(e.g. 22LA1-3C2-K)

### GENERAL SPECIFICATIONS

**Output connector:** 26-pin connector  
(OMRON XG4A-2634)  
**Usable connector type:** OMRON XG4M-2630-T,  
XG5M-263x-N)  
**Usable cover type:** OMRON XG5S-2612  
The special cable (model: MCN26), Connector Terminal  
Block (model: CNT) are available.  
When driving an inductive load, external protection is  
recommended.

### INPUT SPECIFICATIONS

**Hold Input:** TTL level (5V-CMOS level); open collector or dry  
contact (saturation voltage  $\leq 1$  V, sink current 1 mA);  
negative logic

### OUTPUT SPECIFICATIONS

**Output:** Open collector  
**Maximum collector-emitter voltage:** 30 V DC  
**Maximum collector current:** 30 mA  
**Saturation voltage:**  $\leq 1.1$  V; negative logic  
**DAV output (Data available):** Same level as for the output  
code; negative logic  
■ **Starion No.:** Match the number of input and output  
modules

### PERFORMANCE

**Output time:**  $\leq 20$  msec.

### CONNECTOR PIN ASSIGNMENT

PIN NO.	ASSIGNMENT	PIN NO.	ASSIGNMENT
1	$1 \times 10^0 (B^0)$	17	COM
2	$2 \times 10^0 (B^1)$	18	COM
3	$4 \times 10^0 (B^2)$	19	No connection
4	$8 \times 10^0 (B^3)$	20	No connection
5	$1 \times 10^1 (B^4)$	21	DAV
6	$2 \times 10^1 (B^5)$	22	HOLD
7	$4 \times 10^1 (B^6)$	23	COM
8	$8 \times 10^1 (B^7)$	24	COM
9	$1 \times 10^2 (B^8)$	25	No connection
10	$2 \times 10^2 (B^9)$	26	No connection
11	$4 \times 10^2 (B^{10})$		
12	$8 \times 10^2 (B^{11})$		
13	$1 \times 10^3 (B^{12})$		
14	$2 \times 10^3 (B^{13})$		
15	$4 \times 10^3 (B^{14})$		
16	$8 \times 10^3 (B^{15})$		

$B^0 - B^{15}$  are inputs, DAV is an output, and HOLD is an input.

### TERMINAL CONNECTION (OUTPUT)

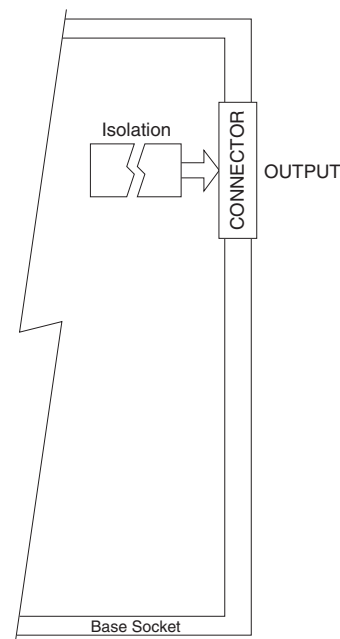

### TIMING CHART

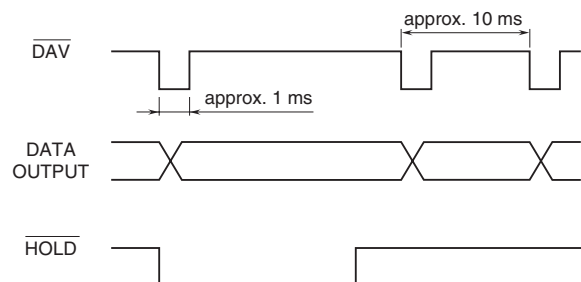

When the HOLD input signal is valid ("L"), the DAV output is not provided and the data output is held at the value before that.

## RELAY OUTPUT MODULE

(Do 8 points)

### MODEL: 22LA1-3C7-[1]

#### ORDERING INFORMATION

• Code number: 22LA1-3C7-[1]

Specify a code from power input options for [1]

(e.g. 22LA1-3C7-K)

#### OUTPUT SPECIFICATIONS

**Output:** Relay contact, 8 points

**Commons:** Per 4 points, 2 points, 2 points

**Contact rating:** 125 V AC @ 0.5 A ( $\cos \theta = 1$ )

30 V DC @ 0.5 A (resistive load)

**Max. switching voltage:** 250 V AC or 125 V DC

**Max. switching power:** 62.5 VA or 60 W

**Min. load:** 10 mV DC @ 1mA

**Mechanical life:**  $5 \times 10^7$  cycles (rate 300/min.)

$10^8$  cycles (rate 180/min.)

When driving an inductive load, external protection is recommended.

■ **Starion No.:** Match the number of input and output modules

#### PERFORMANCE

**Output time**

**OFF to ON:** 8 msec. per 8 points

**ON to OFF:** 3 msec. per 8 points

#### TERMINAL CONNECTION (OUTPUT)

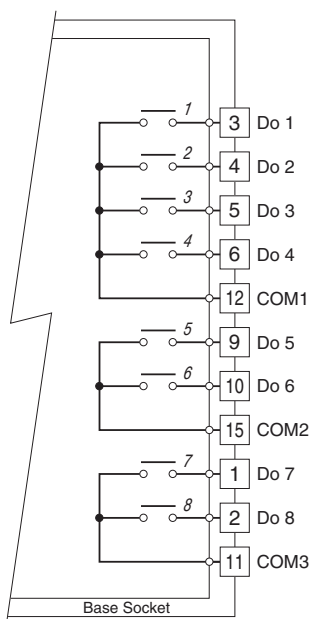

*Italic figures indicate LED No. on the front panel.*

## PHOTO MOSFET RELAY OUTPUT MODULE

(Do 8 points)

### MODEL: 22LA1-3C8-[1]

#### ORDERING INFORMATION

- Code number: 22LA1-3C8-[1]

Specify a code from power input options for [1]

(e.g. 22LA1-3C8-K)

#### OUTPUT SPECIFICATIONS

**Output:** Photo MOSFET relay, 8 points

**Commons:** Per 4 points, 2 points, 2 points

**Contact rating:** 125 V AC/DC @ 50 mA (resistive load)

**Max. ON resistance:** 50 Ω

■ **Starion No.:** Match the number of input and output modules

#### PERFORMANCE

**Output time**

**OFF to ON:** 8 msec. per 8 points

**ON to OFF:** 3 msec. per 8 points

#### TERMINAL CONNECTION (OUTPUT)

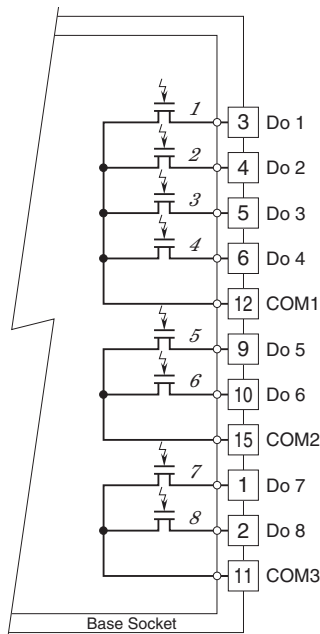

Italic figures indicate LED No. on the front panel.

## CONTACT I/O MODULE

(Di & Do each 4 points; relay contact output)

### MODEL: 22LA1-3E5-[1]

### ORDERING INFORMATION

- Code number: 22LA1-3E5-[1]
- Specify a code from power input options for [1]  
(e.g. 22LA1-3E5-K)

### INPUT SPECIFICATIONS

**Input:** Dry contact, 4 points

**Commons:** Per 4 points

**Sensing:** 12 V DC

≥ 3 mA at ON

≤ 1 mA at OFF

### OUTPUT SPECIFICATIONS

**Output:** Relay contact, 4 points

**Commons:** Per 2 points

**Contact rating:** 125 V AC @ 0.5 A ( $\cos \phi = 1$ )

30 V DC @ 0.5 A (resistive load)

**Max. switching voltage:** 250 V AC or 125 V DC

**Max. switching power:** 62.5 VA or 60 W

**Min. load:** 10 mV DC @ 1 mA

**Mechanical life:**  $5 \times 10^7$  cycles (rate 300/min.)

$10^8$  cycles (rate 180/min.)

When driving an inductive load, external protection is recommended.

■ **Starion No.:** set an even number to one unit and a consecutive odd number to the paired unit. (e.g. "02" and "03", "1A" and "1B")

### PERFORMANCE

**Multi-transmission time:** 1.5 msec.

**Input read time:** 5 msec. per 4 points

**Output time**

**OFF to ON:** 8 msec. per 4 points

**ON to OFF:** 3 msec. per 4 points

### I/O TERMINAL CONNECTION

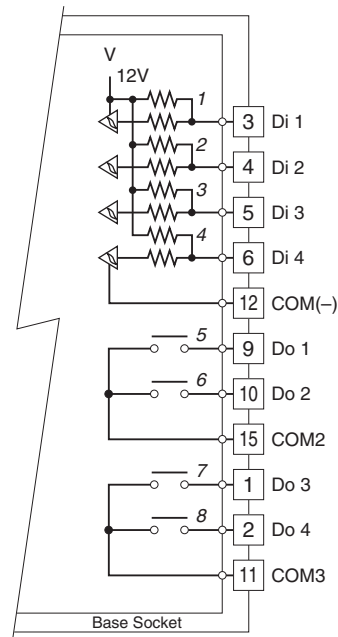

Italic figures indicate LED No. on the front panel.

## CONTACT I/O MODULE

(Di & Do each 4 points; photo MOSFET relay contact output)

## MODEL: 22LA1-3E6-[1]

### ORDERING INFORMATION

- Code number: 22LA1-3E6-[1]
- Specify a code from power input options for [1]  
(e.g. 22LA1-3E6-K)

### INPUT SPECIFICATIONS

**Input:** Dry contact, 4 points

**Commons:** Per 4 points

**Sensing:** 12 V DC

≥ 3 mA at ON

≤ 1 mA at OFF

### OUTPUT SPECIFICATIONS

**Output:** Photo MOSFET relay, 4 points

**Commons:** Per 2 points

**Contact rating:** 125 V AC/DC @ 50 mA (resistive load)

**Max. ON resistance:** 50 Ω

■ **Starion No.:** set an even number to one unit and a consecutive odd number to the paired unit. (e.g. "02" and "03", "1A" and "1B")

### PERFORMANCE

**Multi-transmission time:** 1.5 msec.

**Input read time:** 5 msec. per 4 points

**Output time**

**OFF to ON:** 8 msec. per 4 points

**ON to OFF:** 3 msec. per 4 points

### I/O TERMINAL CONNECTION

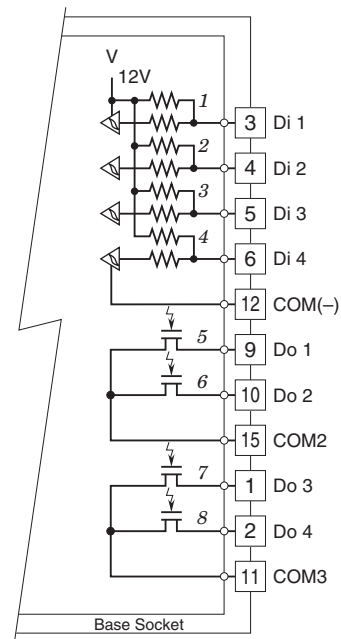

Italic figures indicate LED No. on the front panel.

**ANALOG INPUT MODULE**

(Ai 8 points)

**MODEL: 22LA1-3G3-[1]**

**ORDERING INFORMATION**

• Code number: 22LA1-3G3-[1]  
 Specify a code from power input options for [1]  
 (e.g. 22LA1-3G3-K)

**INPUT SPECIFICATIONS**

Input: 1 - 5 V DC, 8 points  
 Operational range: 0.4 - 5.6 V DC  
 Commons: All negatives  
 Input resistance: 1 MΩ min.  
 ■ Starion No.: Match the number of input and output modules

**PERFORMANCE in percentage of span**

A/D conversion: ±0.2 %  
 Resolution: ≤ 0.025 %  
 Temp. coefficient: ±0.015 %/°C (±0.008 %/°F)  
 A/D conversion cycle: 1 sec. max. per 8 points  
 Multi-transmission time: 12 msec.

**TERMINAL CONNECTION (INPUT)**

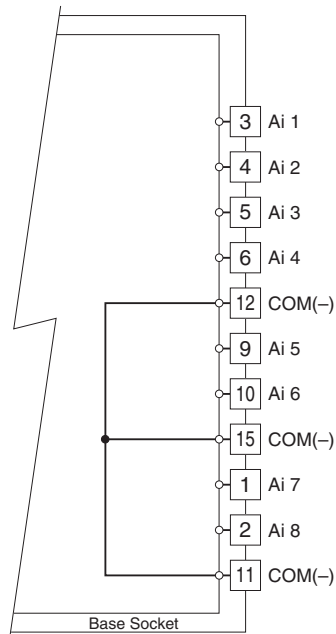



**ANALOG INPUT MODULE**

(Ai 4 points)

**MODEL: 22LA1-3G4-[1]**

**ORDERING INFORMATION**

• Code number: 22LA1-3G4-[1]  
 Specify a code from power input options for [1]  
 (e.g. 22LA1-3G4-K)

**INPUT SPECIFICATIONS**

Input: 1 - 5 V DC, 4 points  
 Operational range: 0.4 - 5.6 V DC  
 Commons: All negatives  
 Input resistance: 1 MΩ min.  
 ■ Starion No.: Match the number of input and output modules

**PERFORMANCE in percentage of span**

A/D conversion: ±0.2 %  
 Resolution: ≤ 0.025 %  
 Temp. coefficient: ±0.015 %/°C (±0.008 %/°F)  
 A/D conversion cycle: 0.5 sec. max. per 4 points  
 Multi-transmission time: 6 msec.

**TERMINAL CONNECTION (INPUT)**

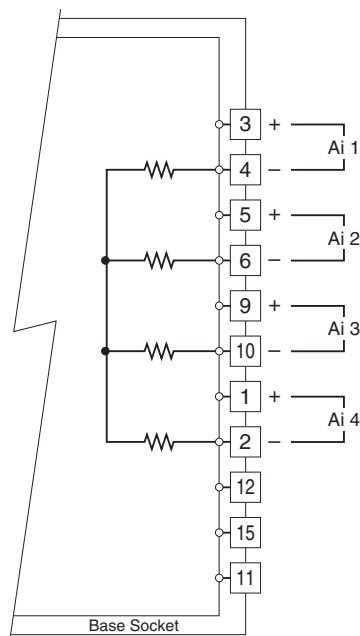

## ANALOG OUTPUT MODULE

(Ao 8 points)

### MODEL: 22LA1-3M3-[1]

#### ORDERING INFORMATION

- Code number: 22LA1-3M3-[1]

Specify a code from power input options for [1]

(e.g. 22LA1-3M3-K)

#### OUTPUT SPECIFICATIONS

**Output:** 1 - 5 V DC, 8 points

**Operational range:** 0.4 - 5.6 V DC

**Commons:** All negatives

**Load resistance:** 10 kΩ min.

■ **Starion No.:** Match the number of input and output modules

#### PERFORMANCE in percentage of span

**D/A conversion cycle:** 1 sec. max. per 8 points

**D/A conversion:** ±0.2 %

**Resolution:** ≤ 0.025 %

**Temp. coefficient:** ±0.015 %/°C (±0.008 %/°F)

#### TERMINAL CONNECTION (OUTPUT)

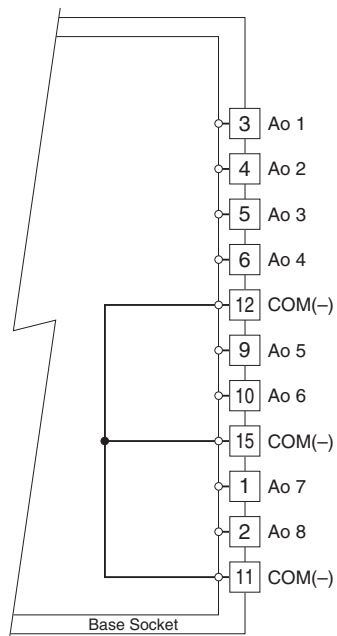

## ANALOG OUTPUT MODULE

(Ao 4 points)

### MODEL: 22LA1-3M4-[1]

#### ORDERING INFORMATION

• Code number: 22LA1-3M4-[1]

Specify a code from power input options for [1]

(e.g. 22LA1-3M4-K)

#### OUTPUT SPECIFICATIONS

**Output:** 1 - 5 V DC, 4 points

**Operational range:** 0.4 - 5.6 V DC

**Commons:** all negatives

**Load resistance:** 10 kΩ min.

■ **Starion No.:** Match the number of input and output modules

#### PERFORMANCE in percentage of span

**D/A conversion cycle:** 0.5 sec. max. per 4 points

**D/A conversion:** ±0.2 %

**Resolution:** ≤ 0.025 %

**Temp. coefficient:** ±0.015 %/°C (±0.008 %/°F)

#### TERMINAL CONNECTION (OUTPUT)

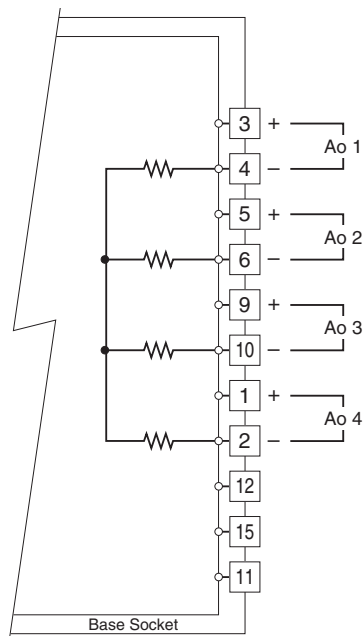

## PULSE INPUT MODULE

(Pi 4 points)

### MODEL: 22LA1-3P4-[1]

#### ORDERING INFORMATION

- Code number: 22LA1-3P4-[1]

Specify a code from power input options for [1]

(e.g. 22LA1-3P4-K)

#### INPUT SPECIFICATIONS

■ **Pulse Input:** Dry contact, 4 points

**Commons:** All negatives

**Frequency:** 0 - 10 kHz (approx.)

**Pulse width requirement:** 20.0 msec. min. for both L and H levels

**Sensing:** 12 V DC

≥ 3 mA at ON; ≤ 1 mA at OFF

**Counter:** 0 - 16383 (3FFF<sub>(16)</sub>); reset to zero at overflow.

■ **Reset input:** Closing across the terminals 9 - 15 at power startup initializes the counter values for Pi 1 thr. 4.

Close for at least 5 sec. after the power start up.

Reset the input unit counter first and then that of the output unit.

■ **Starion No.:** Match the number of input and output modules

#### PERFORMANCE

**Multi-transmission time:** 6 msec.

**Input read time:** 5 msec. per 4 points

#### TERMINAL CONNECTION (INPUT)

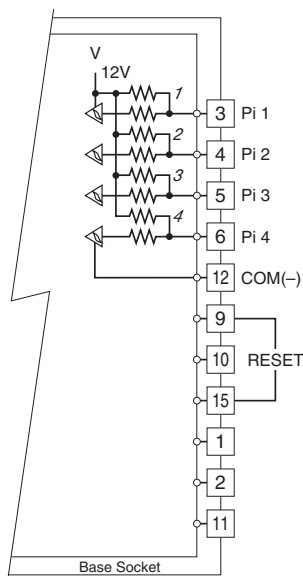

Italic figures indicate LED No. on the front panel.

## PULSE OUTPUT MODULE

(Po 4 points)

### MODEL: 22LA1-3U4-[1]

### ORDERING INFORMATION

- Code number: 22LA1-3U4-[1]  
Specify a code from power input options for [1]  
(e.g. 22LA1-3U4-K)

### INPUT SPECIFICATIONS

- **Reset input:** Closing across the terminals 9 - 15 at power startup initializes the counter values for Po 1 thr. 4. Close for at least 5 sec. after the power start up. Reset the input unit counter first and then that of the output unit.

### OUTPUT SPECIFICATIONS

- Output:** Photo MOSFET relay, 4 points
- Commons:** All negatives
- Max. frequency:** Approx. 10 kHz
- Pulse width:** Approx. 50 % duty ratio at the maximum frequency
- Contact rating:** 125 V AC/DC @ 50 mA (resistive load)
- Max. ON resistance:** 50 Ω
- **Starion No.:** Match the number of input and output modules

### PERFORMANCE

- Output time**
  - OFF to ON:** 8 msec. per 4 points
  - ON to OFF:** 3 msec. per 4 points

### TERMINAL CONNECTION (OUTPUT)

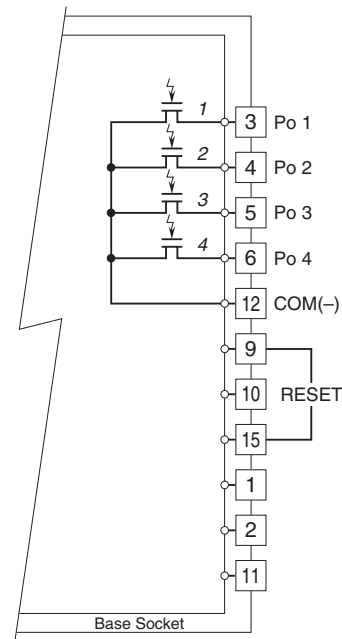

*Italic figures indicate LED No. on the front panel.*



Specifications are subject to change without notice.