

2.5V CMOS 1-TO-10 CLOCK DRIVER

Features

- High frequency > 150MHz
- Guaranteed low skew < 150pS (max.) between any two outputs
- Very low duty cycle distortion < 300pS
- High speed: propagation delay < 3nS
- Very low CMOS power levels
- TTL compatible inputs and outputs
- 1:10 fanout
- Maximum output rise and fall time < 1.25nS (max.)
- Low input capacitance: 3pF (typ)
- 2.5V Supply Voltage
- Available in SSOP and QSOP Packages

Product Description

The PCS2P20807A is a 2.5V compatible, high speed, low noise, 1:10 fanout, non-inverting clock buffer. The large fanout from a single input reduces loading on the preceding driver and provides an efficient clock distribution network.

Providing output to output skew as low as 150pS, the PCS20807A is an ideal clock distribution device for synchronous systems. Multiple power and grounds reduce noise. Typical applications are clock and signal distribution.

Block Diagram

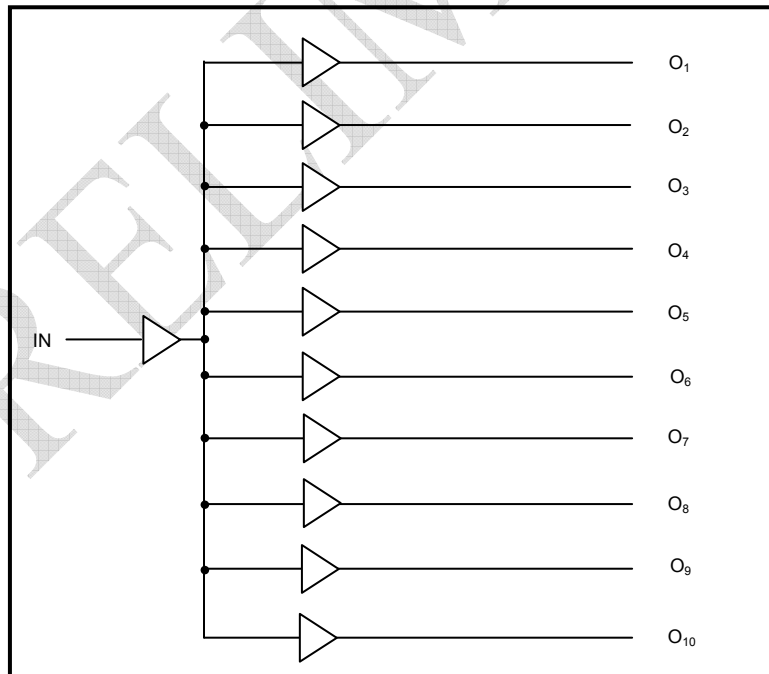

Pin Configuring

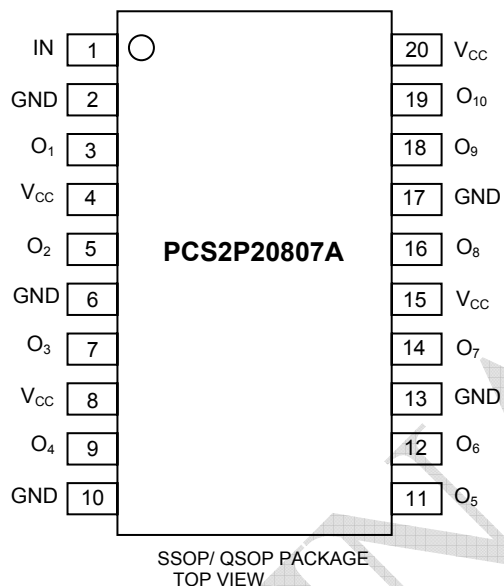

Pin Description

Pin #	Pin Names	Description
1	IN	Clock Input
3,5,7,9,11,12,14,16,18,19	O ₁ -O ₁₀	Clock Outputs
2,6,10,13,17	GND	Ground
4,8,15,20	V _{CC}	Power supply

Capacitance (TA = +25°C, f = 1.0MHz)

Symbol	Parameter ¹	Conditions	Typ	Max	Unit
C _{IN}	Input Capacitance	V _{IN} = 0V	3	4	pF

NOTE:1. This parameter is measured at characterization but not tested.

rev 0.3

Absolute Maximum Ratings¹

Symbol	Description	Max	Unit
V_{TERM}^2	Terminal Voltage with Respect to GND	-0.5 to +4.6	V
V_{TERM}^3	Terminal Voltage with Respect to GND	-0.5 to +5.5	V
V_{TERM}^4	Terminal Voltage with Respect to GND	-0.5 to $V_{CC}+0.5$	V
TSTG	Storage Temperature	-65 to +150	° C
IOUT	DC Output Current	-60 to +60	mA

NOTES:

- These are stress ratings only and are not implied for functional use. Exposure to absolute maximum ratings for prolonged periods of time may affect device reliability.
- V_{CC} terminals.
- Input terminals.
- Outputs and I/O terminals.

Power Supply Characteristics

Symbol	Parameter	Test Conditions ¹	Min	Typ ²	Max	Unit
I_{CCL} I_{CCH}	Quiescent Power Supply Current TTL Inputs HIGH	$V_{CC} = \text{Max}$ $V_{IN} = \text{GND or } V_{CC}$		0.1	20	μA
ΔI_{CC}	Power Supply Current per Input HIGH	$V_{CC} = \text{Max}$ $V_{IN} = V_{CC} - 0.6\text{V}$		45	300	μA
I_{CCD}	Dynamic Power Supply Current per Output ³	$V_{CC} = 2.7\text{V}$ and 15 pF load 150 MHz		40		$\mu\text{A} / \text{MHz}$
I_C	Total Power Supply Current ⁴	$V_{CC} = \text{Max.}$ $C_L = 12\text{pF}$ All outputs toggling $f_i = 150\text{MHz}$	$V_{IN} = V_{CC}$ $V_{IN} = \text{GND}$	105	125	mA
			$V_{IN} = V_{CC} - 0.6\text{V}$ $V_{IN} = \text{GND}$	105	125	

NOTES:

- For conditions shown as Max. or Min., use appropriate value specified under Electrical Characteristics for the applicable device type.
- Typical values are at $V_{CC} = 2.5\text{V}$, +25°C ambient.
- This parameter is not directly testable, but is derived for use in Total Power Supply calculations.
- $I_C = I_{CCL} + I_{CCH} + I_{CCD}$
 $I_C = I_{CC} + \Delta I_{CC} \cdot D_{HNT} + I_{CCD}(f_i)$
 $I_{CC} = \text{Quiescent Current } (I_{CCL}, I_{CCH} \text{ and } I_{CCZ})$
 $\Delta I_{CC} = \text{Power Supply Current for a TTL High Input } (V_{IN} = V_{CC} - 0.6\text{V})$
 $D_H = \text{Duty Cycle for TTL Inputs High}$
 $N_T = \text{Number of TTL Inputs at DH}$
 $I_{CCD} = \text{Dynamic Current Caused by an Input Transition Pair (HLH or LHL)}$
 $f_i = \text{Input Frequency}$

rev 0.3

DC Electrical Characteristics Over Operating Range

Following Conditions Apply Unless Otherwise Specified

Industrial: $T_A = -40^{\circ}\text{C}$ to $+85^{\circ}\text{C}$, $V_{CC} = 2.5\text{V} \pm 0.2\text{V}$

Symbol	Parameter	Test Conditions ¹	Min	Typ ²	Max	Unit
V_{IH}	Input HIGH Level		1.7			V
V_{IL}	Input LOW Level				0.7	V
I_{IH}	Input HIGH Current (Input pins)	$V_{CC} = \text{Max}, V_I = V_{CC}$			± 1	mA
I_{IL}	Input LOW Current (Input pins)	$V_{CC} = \text{Max}, V_I = \text{GND}$			± 1	mA
V_{IK}	Clamp Diode Voltage	$V_{CC} = \text{Min}, I_{IN} = -18\text{mA}$		-0.7	-1	V
I_{ODH}	Output HIGH Current	$V_{CC} = 2.5\text{V}, V_{IN} = V_{IH}$ or V_{IL} $V_O = 1.25\text{V}^3$	-25	-45	-100	mA
I_{ODL}	Output LOW Current	$V_{CC} = 2.5\text{V}, V_{IN} = V_{IH}$ or V_{IL} $V_O = 1.25\text{V}^3$	20	55	120	mA
V_{OH}	Output HIGH Voltage	$V_{CC} = \text{Min}, V_{IN} = V_{IH}$ or V_{IL}	$I_{OH} = -1\text{mA}$	$V_{CC} - 0.2$		V
			$I_{OH} = -8\text{mA}$	1.8^5		
V_{OL}	Output LOW Voltage	$V_{CC} = \text{Min}$	$I_{OL} = 1\text{mA}$		0.4	V
			$I_{OL} = 8\text{mA}$		0.6	
I_{OS}	Short Circuit Current ⁴	$V_{CC} = \text{Max.}, V_O = \text{GND}^3$	-25	-60	-135	mA

NOTES:

1. For conditions shown as Max or Min, use appropriate value specified under Electrical Characteristics for the applicable device type.
2. Typical values are at $V_{CC} = 2.5\text{V}, +25^{\circ}\text{C}$ ambient.
3. Not more than one output should be shorted at one time. Duration of the test should not exceed one second.
4. This parameter is guaranteed but not tested.
5. $V_{OH} = V_{CC} - 0.6\text{V}$ at rated current.

rev 0.3

Switching Characteristics Over Operating Range^{1,2}

Following Conditions Apply Unless Otherwise Specified

Industrial: $T_A = -40^{\circ}\text{C}$ to $+85^{\circ}\text{C}$, $V_{CC} = 2.5\text{V} \pm 0.2\text{V}$

Symbol	Parameter	Conditions ³	Min	Typ	Max	Unit
t_{PLH} t_{PHL}	Propagation Delay	$C_L = 22\text{pF}$ 100 MHz		3	3.5	nS
t_R	Output Rise Time			1	1.25	nS
t_F	Output Fall Time			1	1.25	nS
$t_{SK(O)}$	Same Device Output Pin-to-Pin Skew ⁴			100	150	pS
$t_{SK(P)}$	Pulse Skew ⁵			250	300	pS
$t_{SK(PP)}$	Part-to-Part Skew ⁶			400	600	pS

Symbol	Parameter	Conditions ^{3,7}	Min	Typ	Max	Unit
t_{PLH} t_{PHL}	Propagation Delay	$C_L = 12\text{pF}$ 150 MHz		2.4	2.7	nS
t_R	Output Rise Time			1	1.2	nS
t_F	Output Fall Time			1	1.2	nS
$t_{SK(O)}$	Same Device Output Pin-to-Pin Skew ⁴			100	150	pS
$t_{SK(P)}$	Pulse Skew ⁵			250	300	pS
$t_{SK(PP)}$	Part-to-Part Skew ⁶			400	600	pS

NOTES:

- t_{PLH} and t_{PHL} are production tested. All other parameters guaranteed but not production tested.
- Propagation delay range indicated by Min. and Max. limit is due to VCC, operating temperature and process parameters. These propagation delay limits do not imply skew.
- See test circuits and waveforms.
- Skew measured between all outputs under identical transitions and load conditions.
- Skew measured is difference between propagation delay times t_{PHL} and t_{PLH} of same output under identical load conditions.
- Part to part skew for all outputs given identical transitions and load conditions at identical VCC levels and temperature.
- Airflow of 1m/s is recommended for frequencies above 133MHz.

Test Circuits and Waveforms

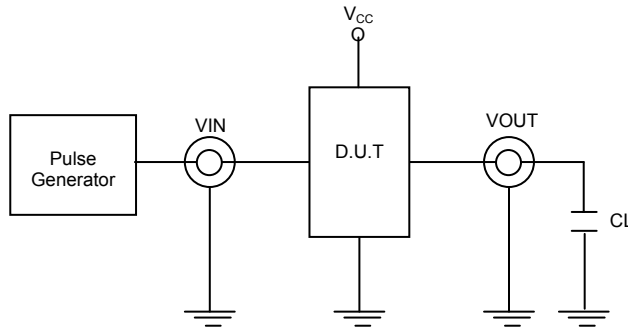

CL = Load Capacitance: Includes Jig and Capacitance probe

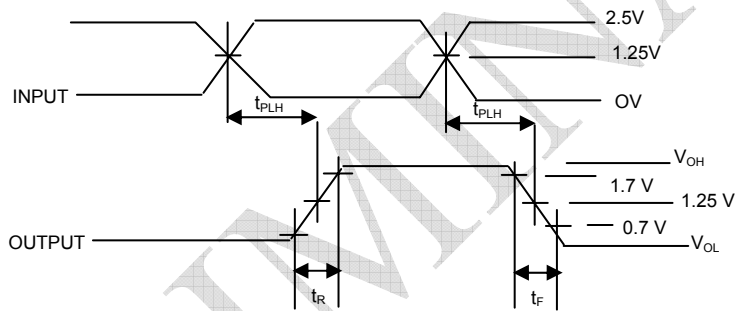

Propagation Delay

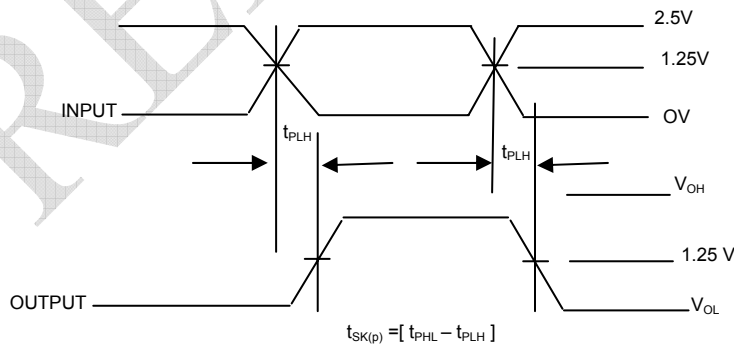

Pulse Skew - $t_{SK(P)}$

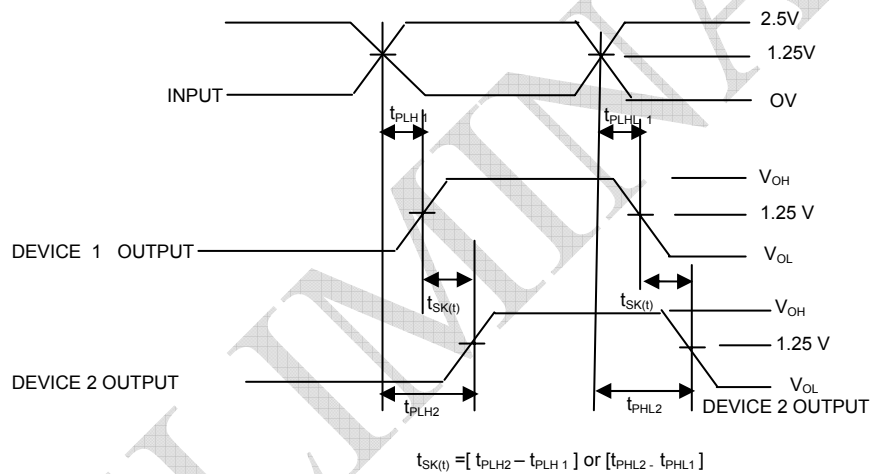
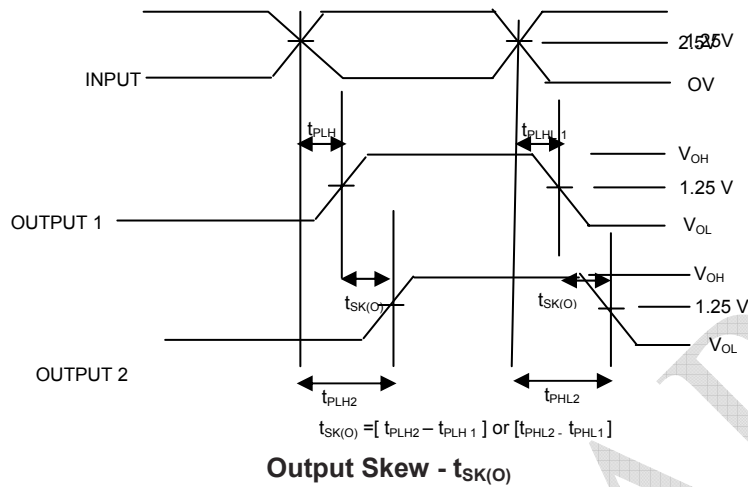

NOTE: Device 1 and device 2 are same package type and speed grade.

Test Conditions

Symbol	VCC = 2.5V ±0.2V	Unit
C _L	22 ¹	pF
	12 ²	
R _T	Z _{OUT} of pulse generator	Ω
t _R / t _F	1.25 ¹	nS
	1.2 ²	

DEFINITIONS:
 C_L = Load capacitance: includes jig and probe capacitance.
 R_T = Termination resistance: should be equal to Z_{OUT} of the Pulse Generator.
 t_R / t_F = Rise/Fall time of the input stimulus from the Pulse Generator.

NOTES:
 1. Test conditions at 100MHz.
 2. Test conditions at 150MHz.

20-lead SSOP (209 mil)

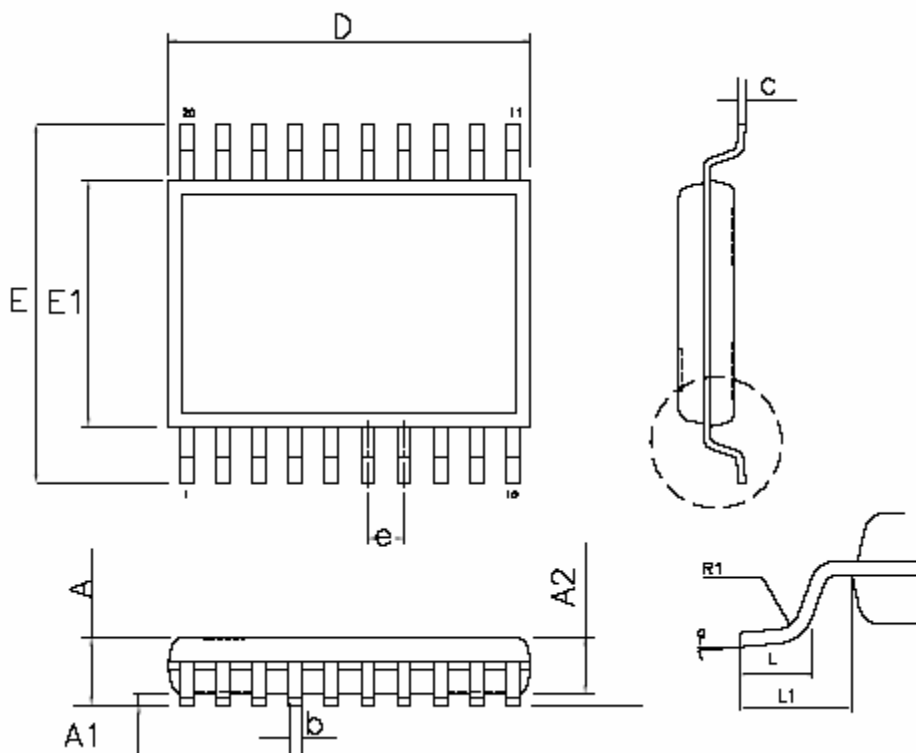

Symbol	Dimensions			
	Inches		Millimeters	
	Min	Max	Min	Max
A	0.053	0.069	1.346	1.753
A1	0.004	0.010	0.102	0.254
A2	0.059	1.499
D	0.337	0.344	8.560	8.738
c	0.007	0.011	0.178	0.274
E	0.228	0.244	5.791	6.198
E1	0.150	0.157	3.810	3.988
L	0.016	0.035	0.406	0.890
L1	0.010 BASIC		0.254 BASIC	
b	0.008	0.014	0.203	0.356
R1	0.003	0.08
a	0°	8°	0°	8°
e	0.025 BASIC		0.635 BASIC	

rev 0.3

Package Information

20-lead QSOP

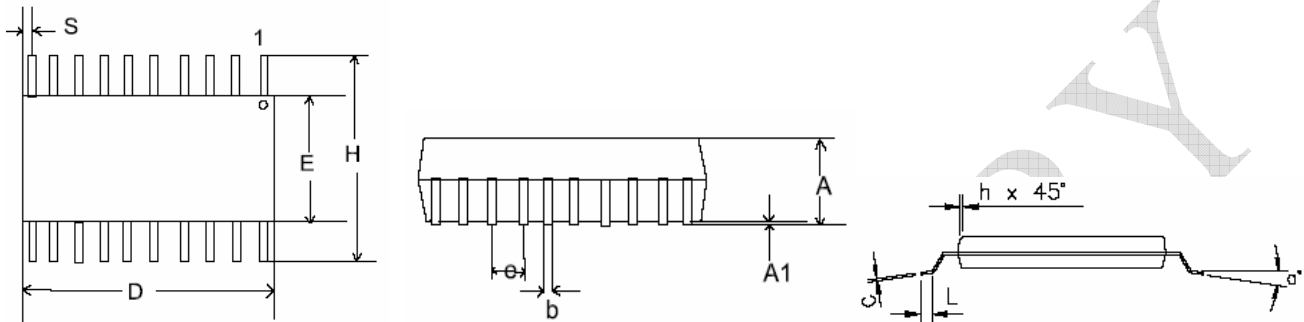

Symbol	Dimensions			
	Inches		Millimeters	
	Min	Max	Min	Max
A	0.060	0.068	1.52	1.73
A1	0.004	0.008	0.10	0.20
b	0.009	0.012	0.23	0.30
c	0.007	0.010	0.18	0.25
D	0.337	0.344	8.56	8.74
E	0.150	0.157	3.81	3.99
e	0.025 BSC		0.64 BSC	
H	0.230	0.244	5.84	6.20
h	0.010	0.016	0.25	0.41
L	0.016	0.035	0.41	0.89
S	0.056	0.060	1.42	1.52
a	0°	8°	0°	8°



Giving you the edge

September 2006

PCS2P20807A

rev 0.3

Ordering Information

Part Number	Marking	Package Type	Temperature
PCS2P20807AG-20-AR	2P20807AG	20-Pin SSOP, TAPE & REEL , Green	Commercial
PCS2P20807AG-20-AT	2P20807AG	20-Pin SSOP, TUBE, Green	Commercial
PCS2P20807AG-20-DR	2P20807AG	20-Pin QSOP, TAPE & REEL, Green	Commercial
PCS2P20807AG-20-DT	2P20807AG	20-Pin QSOP, TUBE, Green	Commercial
PCS2I20807AG-20-AR	2I20807AG	20-Pin SSOP, TAPE & REEL, Green	Industrial
PCS2I20807AG-20-AT	2I20807AG	20-Pin SSOP, TUBE, Green	Industrial
PCS2I20807AG-20-DR	2I20807AG	20-Pin QSOP, TAPE & REEL, Green	Industrial
PCS2I20807AG-20-DT	2I20807AG	20-Pin QSOP, TUBE, Green	Industrial

Device Ordering Information

PCS2P20807AG-20-AR

R = Tape & Reel, T = Tube or Tray

O = SOT	U = MSOP
S = SOIC	E = TQFP
T = TSSOP	L = LQFP
A = SSOP	U = MSOP
V = TVSOP	P = PDIP
B = BGA	D = QSOP
Q = QFN	X = SC-70

DEVICE PIN COUNT

G = GREEN PACKAGE, LEAD FREE, and RoHS

PART NUMBER

X= Automotive (-40C to +125C)	I= Industrial (-40C to +85C)	P or n/c = Commercial (0C to +70C)
----------------------------------	---------------------------------	---------------------------------------

1 = Reserved	6 = Power Management
2 = Non PLL based	7 = Power Management
3 = EMI Reduction	8 = Power Management
4 = DDR support products	9 = Hi Performance
5 = STD Zero Delav Buffer	0 = Reserved

PulseCore Semiconductor Mixed Signal Product

Licensed under US patent Nos 5,488,627 and 5,631,920.



Giving you the edge

September 2006

PCS2P20807A

rev 0.3



Giving you the edge

PulseCore Semiconductor Corporation
1715 S. Bascom Ave Suite 200
Campbell, CA 95008
Tel: 408-879-9077
Fax: 408-879-9018
www.pulsecoresemi.com

Copyright © PulseCore Semiconductor
All Rights Reserved
Preliminary Information
Part Number: PCS2P20807A
Document Version: v0.3

Note: This product utilizes US Patent # 6,646,463 Impedance Emulator Patent issued to PulseCore Semiconductor, dated 11-11-2003

© Copyright 2006 PulseCore Semiconductor Corporation. All rights reserved. Our logo and name are trademarks or registered trademarks of PulseCore Semiconductor. All other brand and product names may be the trademarks of their respective companies. PulseCore reserves the right to make changes to this document and its products at any time without notice. PulseCore assumes no responsibility for any errors that may appear in this document. The data contained herein represents PulseCore's best data and/or estimates at the time of issuance. PulseCore reserves the right to change or correct this data at any time, without notice. If the product described herein is under development, significant changes to these specifications are possible. The information in this product data sheet is intended to be general descriptive information for potential customers and users, and is not intended to operate as, or provide, any guarantee or warranty to any user or customer. PulseCore does not assume any responsibility or liability arising out of the application or use of any product described herein, and disclaims any express or implied warranties related to the sale and/or use of PulseCore products including liability or warranties related to fitness for a particular purpose, merchantability, or infringement of any intellectual property rights, except as express agreed to in PulseCore's Terms and Conditions of Sale (which are available from PulseCore). All sales of PulseCore products are made exclusively according to PulseCore's Terms and Conditions of Sale. The purchase of products from PulseCore does not convey a license under any patent rights, copyrights; mask works rights, trademarks, or any other intellectual property rights of PulseCore or third parties. PulseCore does not authorize its products for use as critical components in life-supporting systems where a malfunction or failure may reasonably be expected to result in significant injury to the user, and the inclusion of PulseCore products in such life-supporting systems implies that the manufacturer assumes all risk of such use and agrees to indemnify PulseCore against all claims arising from such use.