

AEAT-6010/6012 Magnetic Encoder

10 or 12 bit Angular Detection Device



Data Sheet

Description

Avago Technologies' AEAT-60xx series of magnetic encoders provides an integrated solution for angular detection. With ease of use in mind, these magnetic encoders are ideal for angular detection within 360°. Based on magnetic technologies, the device is non-contact and ensures reliable operations. It is able to provide absolute angle detection upon power-up, with a resolution of 0.0879°(12 bits version) or 0.35°(10bits version), which is equivalent to 4096 and 1024 positions per revolution respectively. The positional data is provided in serial bit stream. There is no upper speed limit; the only restriction is that there will be fewer samples per revolution as the speed increases.

Exploded View

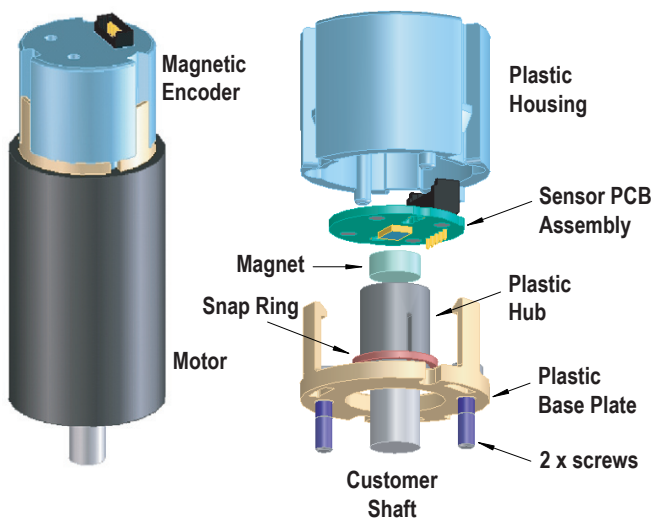

Features

- 10 or 12 bits resolution
- Contactless sensing technologies
- Wide temperature range from -40° to 125°C
- Absolute angular position detection
- Synchronous serial interface (SSI) output for absolute position data (binary format)
- Code monotony error = ± 1 LSB
- Single 5V supply
- Easy Assembly, No Signal Adjustment required
- Direct Connectivity through PCB
- RoHS compliant

Applications

- Flow meter
- Angular detection
- Knob control
- Rotary encoder

Note: "This product is not specifically designed or manufactured for use in any specific device. Customers are solely responsible for determining the suitability of this product for its intended application and solely liable for all loss, damage, expense or liability in connection with such use."

Device Selection Guide ^[1]

Part Number	Resolution (bit)	Operating Temperature (°C)	Output Communication	DC Supply Voltage (V), V _{DD}
AEAT-6012	12	-40 to +125	Serial	+5.0
AEAT-6010	10	-40 to +125	Serial	+5.0

Notes:

- For other options of Magnetic Encoder, please refer to factory.

Table 1. Absolute Maximum Ratings ^[1, 2]

Parameter	Symbol	Limits	Units	Notes
DC Supply Voltage at pin V _{DD} = 5V	V _{DD}	-0.3 to +7	V	
Input Voltage	V _i	-0.3 to V _{DD} +0.3	V	
Storage Temperature	T _{STG}	-40 to 125	°C	

Notes:

- Stresses greater than those listed under Absolute Maximum Ratings may cause permanent damage to the device. This is stress rating only and functional operation of the device at these or any other conditions above those indicated in the operational sections of this specification is not implied.
- Exposure to absolute maximum rating conditions for extended periods may affect reliability.

Table 2. Recommended Operating Condition

Parameter	Symbol	Values	Units	Notes
DC Supply Voltage at pin V _{DD} = 5V	V _{DD}	+4.5 / +5.5	V	
Ambient Temperature	T _{amb}	-40 to +125	°C	
Maximum Read-out Frequency	f _{CLK}	≤1	MHz	>0 MHz

Table 3. DC Characteristics

DC Characteristics over Recommended Operating Range, typical at 25 °C

Parameter	Symbol	Condition	Values			Units	Notes
			Min	Typ.	Max		
V _{DD} Supply Current	I _{DD}			16	20	mA	
Output High Voltage D0	V _{OH}		V _{DD} -0.5			V	
Output Low Voltage D0	V _{OL}				V _{SS} +0.4	V	
Output Current D0	I _o				4	mA	V _{DD} pin = 4.5V
Input High Voltage CLK, CSn	V _{IH}		0.7*V _{DD}				1
Input Low Voltage CLK, CSn	V _{IL}				0.3*V _{DD}		

Notes:

- CSn is internal pull-up.

Table 4. Timing Characteristics

Timing Characteristics over Recommended Operating Range, typical at 25 °C

Parameter	Symbol	Condition	Values			Units	Notes
			Min	Typ.	Max		
Data output activated (logic high)	$T_{DO\ active}$				100	ns	2
First data shifted to output register	$t_{CLK\ FE}$		500			ns	3
Start of data output	$T_{CLK/2}$		500			ns	4
Data output valid	$T_{DO\ valid}$				375	ns	5
Data output tristate	$T_{DO\ tristate}$				100	ns	6
Pulse width of CSn	T_{CSn}		500			ns	7
Sampling rate for absolute output	f_{abs}		9.9	10.42	10.94	kHz	8

Notes:

2. Time between falling edge of CSn and data output activated
3. Time between falling edge of CSn and first falling edge of CLK
4. Rising edge of CLK shifts out one bit a time
5. Time between rising edge of CLK and data output valid
6. After the last bit DO changes back to "tristate"
7. CSn=high; To initiate read-out of next angular position
8. Internal sampling rate.

Package Dimensions

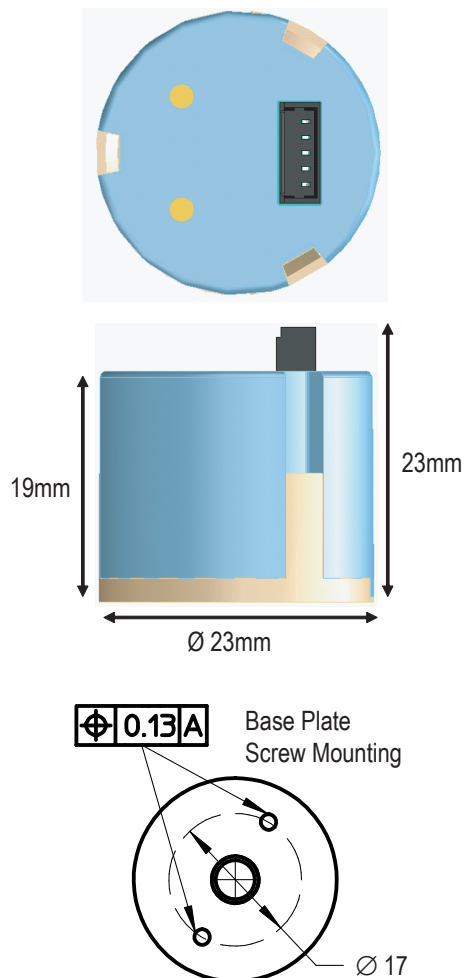

Parameters

No.	Parameter	Value
1	Operating Temp(°C)	- 40 to +125
2	Shaft axial play (mm)	± 0.08
3	Shaft TIR (mm)	0.05
4	Mechanical speed (rpm)	12,000
5	Shaft diameter (mm)	6 + 0 / -0.01
6	Moment inertia (g-cm ²)	0.104
7	Shaft length – (mm)	8.5 ±1.0
8	Mounting screw size (mm)	M2 x 0.4 x 4 (socket head cap screw, head Ø3.8 ± 0.18 mm)
9	Recommended screw torque	0.6 lb.inch
10	Encoder base plate thickness (mm)	2
11	Bolt circle	± 0.13

* Note:- For high temperature application, it is highly recommended that adhesive be applied at least to the screw and the base plate interface. Refer Application Note for further details.

Figure 1. Package and recommended mounting dimension

Timing Characteristics

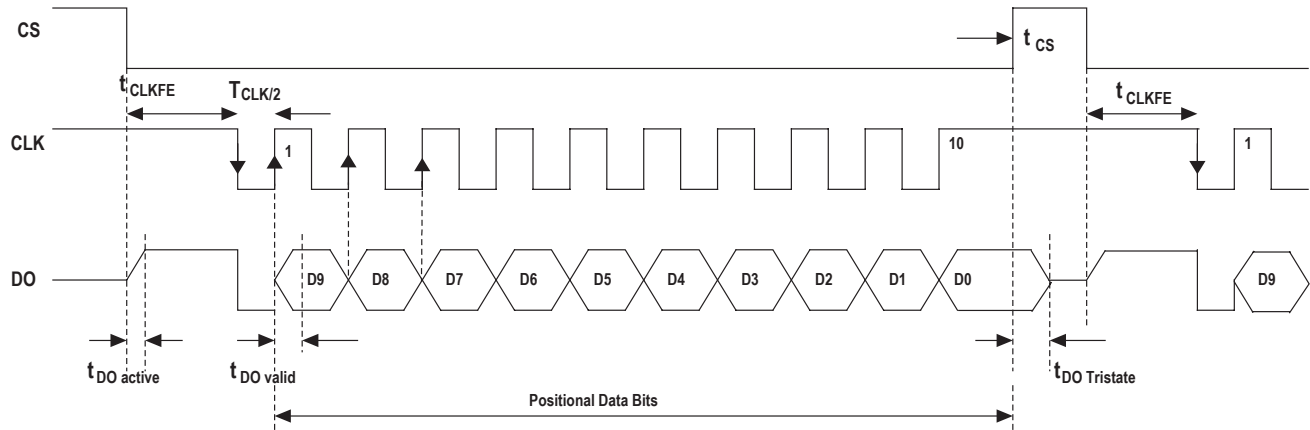

Notes:

1. Please refer to Table 4 for Timing Characteristics.
2. For 12 bits version; the Positional Data Bits will start with D11 instead and end at D0.

Figure 2. Timing Diagram for 10 bit Magnetic Encoder

Electrical Connections

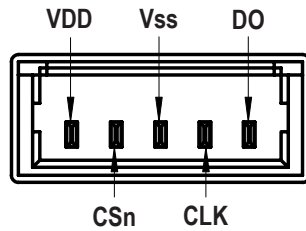

Pin	Symbol	Description
1	VDD	5V Supply Voltage
2	CSn	Chip Select – Input (See Figure 2)
3	VSS	Supply Ground
4	CLK	Serial Clock - Input (See Figure 2)
5	DO	Serial Data - Output. (See Figure 2)

Figure 3. Electrical Connections

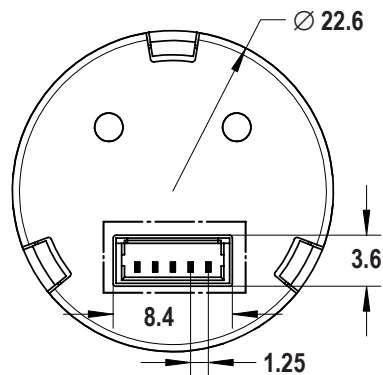

Figure 4. Basic connector dimensions

For product information and a complete list of distributors, please go to our web site: www.avagotech.com

Avago, Avago Technologies, and the A logo are trademarks of Avago Technologies, Limited in the United States and other countries. Data subject to change. Copyright © 2007 Avago Technologies Limited. All rights reserved. AV02-0188EN - March 20, 2007

AVAGO
TECHNOLOGIES