

FERROXCUBE

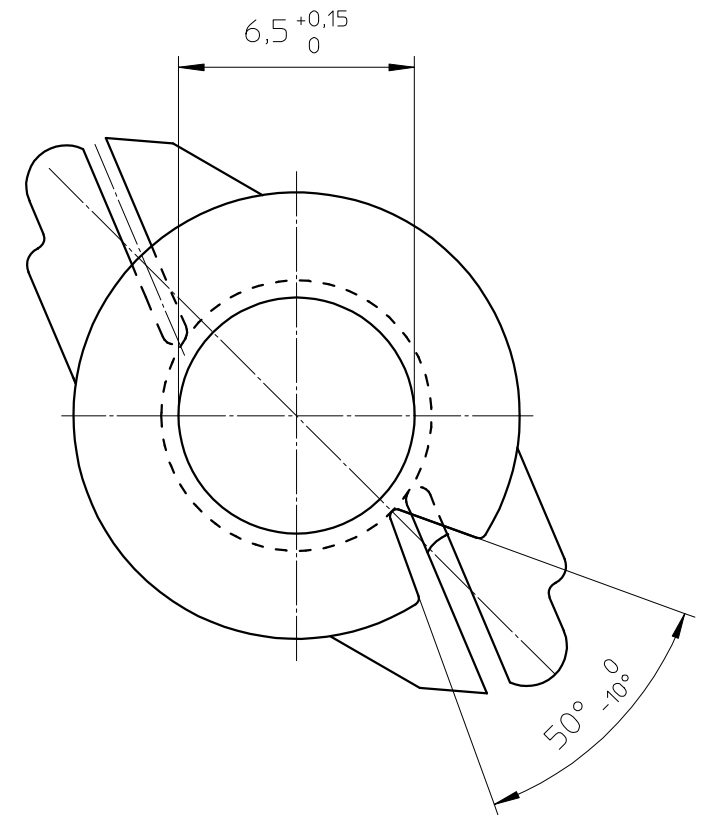

HOLE PATTERN:

Space requirement 6x6 pitch.

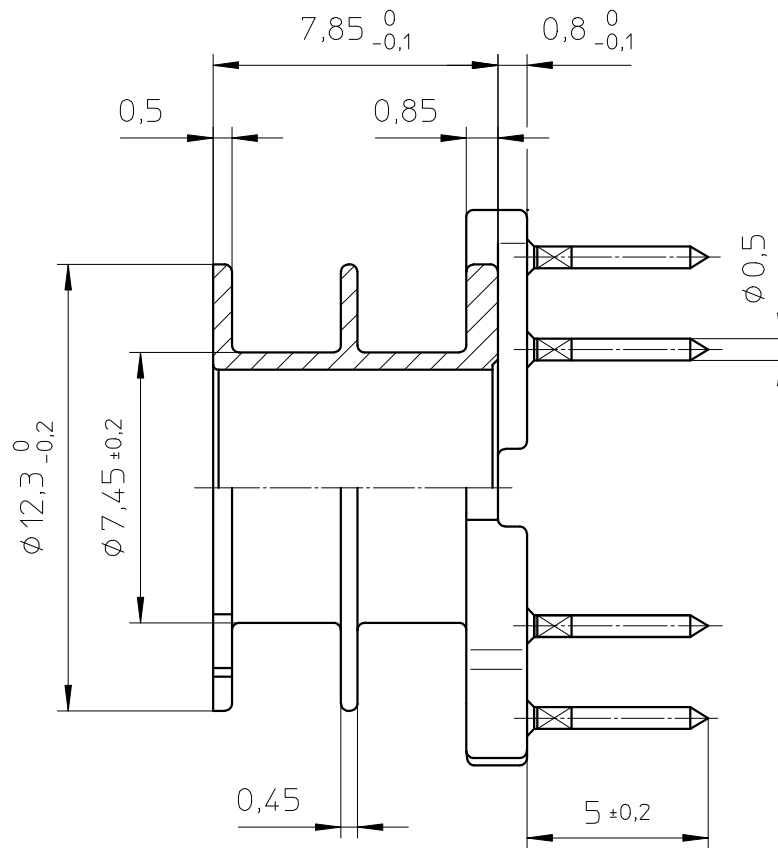
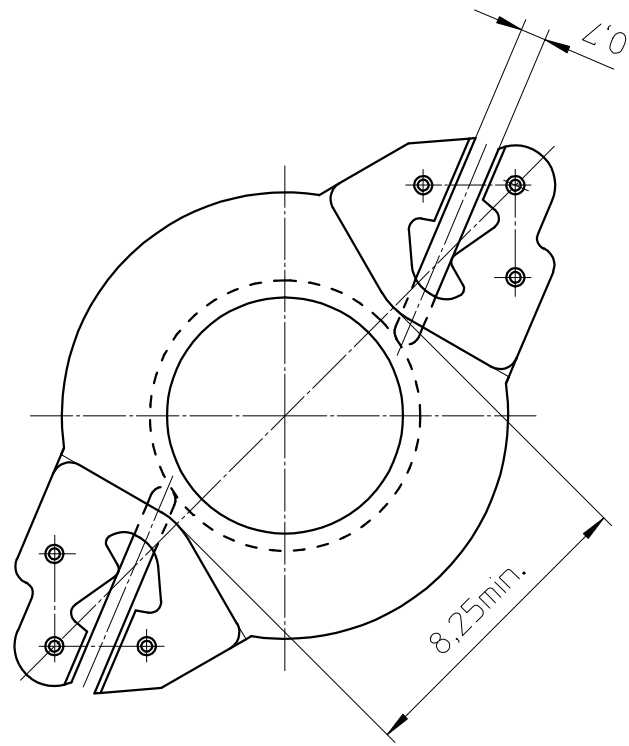
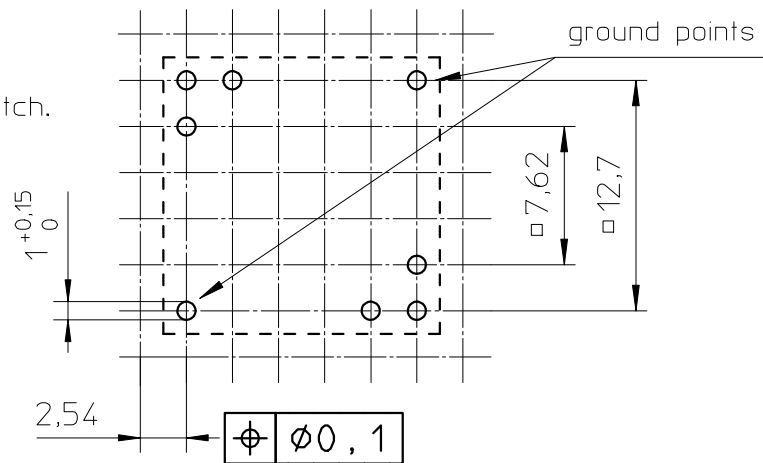

Coil former material:

Bakelite UP 3420 (UP), glass-reinforced.

Pin material:

UL file number: E61040 - UL94V-0.

Max. operating temp.:

CuSn - Ni flash, Sn plated.

Resistance to soldering heat:

acc. to IEC 60 085 class H, 180°C.

Solderability:

acc. to IEC 60 068-2-20 Part 2, Test Tb, method 1B, 350°C - 3,5sec

Min. winding area:

13.8 mm².

Mean length of turn:

30 mm.

CLASS.NO.	CSV-RM6S-2S-6P		4322 021 34601	00-05-24	
				00-08-01	
				02-04-04	
				03-06-30	
				05-09-01	
NAME NAAM	M.Veekens	SUPERS. VERV.	1 SH BL 112 - 001	010	A3
MPA	CHECK CONTR.	DAT.	89-11-21	Property of Eigendom van	© FERROXCUBE 2000