



SURFACE MOUNT TRANSIENT VOLTAGE SUPPRESSOR

SMB5.0 THRU SMB170CA

Stand-off Voltage	5.0 to 170 Volts
Peak Pulse Power	600 Watts

FEATURES

- Plastic package has Underwriters Laboratory Flammability Classification 94V-O
- For surface mounted applications in order to optimize board space
- Low profile package
- Built-in strain relief
- Glass passivated junction
- Low incremental surge resistance
- 600W peak pulse power capability with a 10/1000 μ s Waveform, repetition rate (duty cycle): 0.01%
- Excellent clamping capability
- Fast response time: typically less than 1.0ps from 0 Volts to $V_{(BR)}$ for unidirectional and 5.0ns for bidirectional types
- For devices with $V_{(BR)} \geq 10V$, I_D are typically I_D less than 1.0 μ A
- High temperature soldering guaranteed:
250°C/10 seconds at terminals

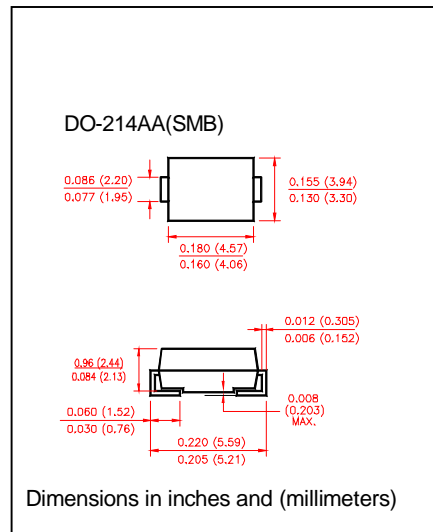

MECHANICAL DATA

- Cass: JEDEC DO-214AA, molded plastic body over passivated junction
- Terminals: Axial leads, solderable per MIL-STD-750, Method 2026
- Polarity: Color bands denotes positive end (cathode) except bidirectional
- Mounting position: any
- Weight: 0.003 ounces, 0.093 gram

DEVICES FOR BIDIRECTIONAL APPLICATIONS

- For bidirectional use C or CA suffix for types SMB-5.0 thru SMB-170 (e.g. SMBG5.0C, SMBJ170CA)
.Electrical Characteristics apply in both directions.

MAXIMUM RATINGS AND ELECTRICAL CHARACTERISTICS

- Ratings at 25°C ambient temperature unless otherwise specified

Ratings	Symbols	Value	Unit
Peak Pulse power dissipation with a 10/1000 μ s waveform(NOTE1,2,FIG.1)	P _{PPM}	Minimum 600	Watts
Peak Pulse current with a 10/1000 μ s waveform (NOTE1,FIG.3)	I _{PPM}	See Table 1	Amps
Peak forward surge current, 8.3ms single half sine-wave superimposed on rated load (JEDEC Method) (Note2,3) – unidirectional only	I _{FSM}	100.0	Amps
Maximum instantaneous forward voltage at 50A (NOTE 3,4) unidirectional only (NOTE 3)	V _F	SEE NOTE 4	Volts
Operating Junction and Storage Temperature Range	T _J , T _{STG}	50 to +150	°C

Notes:

1. Non-repetitive current pulse, per Fig.3 and derated above $T_A=25^\circ\text{C}$ per Fig.2
2. Mounted on 0.2×0.2" (5.0×5.0mm) copper pads to each terminal
3. Measured on 8.3ms single half sine-wave or equivalent square wave duty cycle = 4 pulses per minutes maximum.
4. $V_F=3.5$ V on SMB thru SMB-90 devices and $V_F=5.0V$ on SMB-100 thru SMB-170 devices



SURFACE MOUNT TRANSIENT VOLTAGE SUPPRESSOR

SMB5.0 THRU SMB170CA

Stand-off Voltage 5.0 to 170 Volts
Peak Pulse Power 600 Watts

Electrical Characteristic at (T_A =25°C unless otherwise noted)

Device Type	Device Marking Code		Breakdown Voltage V _(BR) (Volts) (Note 1)		Test Current at I _r (mA)	Stand-off Voltage V _{WM} (Volts)	Maximum Reverse Leakage I _D at V _{WM} (μ A)(Note3)	Maximum Peak Pulse Surge Current I _{PPM} (Note 2)(Amps)	Maximum Clamping Voltage at I _{PPM} V _c (Volts)
	UNI	BI	MIN	MAX					
SMB5.0	5V0	5V0C	6.4	7.82	10	5	800	62.5	9.6
SMB5.0A	5V0A	5V0C	6.4	7.07	10	5	800	65.2	9.2
SMB6.0	6V0	6V0C	6.67	8.15	10	6	800	52.3	11.4
SMB6.0A	6V0A	6V0C	6.67	7.37	10	6	800	58.3	10.3
SMB6.5	6V5	6V5C	7.22	8.82	10	6.5	500	48.8	12.3
SMB6.5A	6V6A	6V6C	7.22	7.98	10	6.5	500	53.6	11.2
SMB7.0	7V0	7V0C	7.78	9.51	10	7	200	45.1	13.3
SMB7.0A	7V0A	7V0C	7.78	8.6	10	7	200	50	12
SMB7.5	7V5	7V5C	8.33	10.2	1	7.5	100	42	14.3
SMB7.5A	7V5A	7V5C	8.33	9.21	1	7.5	100	46.5	12.9
SMB8.0	8V0	8V0C	8.89	10.9	1	8	50	40	15
SMB8.0A	8V0A	8V0C	8.89	9.83	1	8	50	44.1	13.6
SMB8.5	8V5	8V5C	9.44	11.5	1	8.5	20	37.7	15.9
SMB8.5A	8V5	8V5C	9.44	10.4	1	8.5	20	41.7	14.4
SMB9.0	9V0	9V0C	10	12.2	1	9	10	35.5	16.9
SMB9.0A	9V0A	9V0C	10	11.1	1	9	10	39	15.4
SMB10	10V	10VC	11.1	13.6	1	10	5	31.9	18.8
SMB10A	10VA	10VC	11.1	12.3	1	10	5	35.3	17
SMB11	1V1	11VC	12.2	14.9	1	11	5	29.9	20.1
SMB11A	11VA	11VC	12.2	13.5	1	11	5	33	18.2
SMB12	12V	12VC	13.3	16.3	1	12	5	27.3	22
SMB 12A	12VA	12VC	13.3	14.7	1	12	5	30.2	19.9
SMB13	13V	13VC	14.4	17.6	1	13	5	25.2	23.8
SMB13A	13VA	13VC	14.4	15.9	1	13	5	27.9	21.5
SMB14	14V	14VC	15.6	19.1	1	14	5	23.3	25.8
SMB14A	14VA	14VC	15.6	17.2	1	14	5	25.9	23.2
SMB15	15V	15VC	16.7	20.4	1	15	5	22.3	26.9
SMB15A	15VA	15VC	16.7	18.5	1	15	5	24.6	24.4
SMB16	16V	16VC	178	21.8	1	16	5	20.8	28.8
SMB16A	16VA	16VC	178	19.7	1	16	5	23.1	26
SMB17	17V	17VC	18.9	23.1	1	17	5	19.7	30.5
SMB17A	17VA	17VC	18.9	20.9	1	17	5	21.7	27.6
SMB18	18V	18VC	20	24.4	1	18	5	18.6	32.2
SMB18A	18VA	18VC	20	22.1	1	18	5	20.5	29.2
SMB20	20V	20VC	22.2	27.1	1	20	5	16.8	35.8
SMB20A	20VA	20VC	22.2	24.5	1	20	5	18.5	32.4
SMB22	22V	22VC	24.4	29.8	1	22	5	15.2	39.4
SMB22A	22VA	22VC	24.4	26.9	1	22	5	16.9	35.5
SMB24	24V	24VC	26.7	32.6	1	24	5	14	43
SMB24A	24VA	24VC	26.7	29.5	1	24	5	15.4	38.9
SMB26	26V	26VC	28.9	35.3	1	26	5	12.9	46.6
SMB26A	26VA	26VC	28.9	31.9	1	26	5	14.3	42.1
SMB28	28V	28VC	31.1	38	1	28	5	12	50
SMB28A	28VA	28VC	31.1	34.4	1	28	5	13.2	45.4
SMB30	30V	30VC	33.3	40.7	1	30	5	11.2	53.5
SMB30A	30VA	30VC	33.3	36.8	1	30	5	12.4	44
SMB33	33V	33C	36.7	44.9	1	33	5	10.2	59
SMB33A	33VA	33VC	36.7	40.6	1	33	5	11.3	53.3



SURFACE MOUNT TRANSIENT VOLTAGE SUPPRESSOR

SMB5.0 THRU SMB170CA

Stand-off Voltage 5.0 to 170 Volts
Peak Pulse Power 600 Watts

Electrical Characteristic at (T_A = 25°C unless otherwise noted)

Device Type	Device Marking Code		Breakdown Voltage V _(BR) (Volts) (Note 1)		Test Current at I _T (mA)	Stand-off Voltage V _{WM} (Volts)	Maximum Reverse Leakage I _D at V _{WM} (μ A)(Note3)	Maximum Peak Pulse Surge Current I _{PPM} (Note 2)(Amps)	Maximum Clamping Voltage at I _{PPM} V _C (Volts)
	UNI	BI	MIN	MAX					
SMB36	36V	36VC	40	48.9	1	36	5	9.3	64.3
SMB36A	36VA	36VCA	40	44.2	1	36	5	10.3	58.1
SMB40	40V	40VC	44.4	54.3	1	40	5	8.4	71.4
SMB40A	40VA	40VCA	44.4	49.1	1	40	5	9.3	65.4
SMB43	43V	43VC	47.8	58.4	1	43	5	7.8	76.7
SMB43A	43VA	43VCA	47.8	52.8	1	43	5	8.6	69.4
SMB45	45V	45VC	50	61.1	1	45	5	7.5	80.3
SMB45A	45VA	45VCA	50	55.3	1	45	5	8.3	72.7
SMB48	48V	48VC	53.3	65.1	1	48	5	7	85.5
SMB48A	48VA	48VCA	53.3	58.9	1	48	5	7.8	77.4
SMB51	51V	51VC	56.7	69.3	1	51	5	6.6	91.1
SMB51A	51VA	51VCA	56.7	62.7	1	51	5	7.3	82.4
SMB54	54V	54VC	60	73.3	1	54	5	6.2	96.3
SMB54A	54VA	54VCA	60	66.3	1	54	5	6.9	87.1
SMB 58	58V	58VC	64.4	78.7	1	58	5	5.8	102
SMB58A	58VA	58VCA	64.4	71.2	1	58	5	6.4	93.6
SMB60	60V	60VC	66.7	81.5	1	60	5	5.6	107
SMB60A	60VA	60VCA	66.7	73.7	1	60	5	6.2	96.8
SMB64	64V	64VC	71.1	86.9	1	64	5	5.3	114
SMB64A	64VA	64VCA	71.1	78.6	1	64	5	5.8	103
SMB70	70V	70VC	77.8	95.1	1	70	5	4.8	125
SMB70A	70VA	70VCA	77.8	86	1	70	5	5.3	113
SMB75	75V	75VC	83.3	102	1	75	5	4.5	134
SMB75A	75VA	75VCA	83.3	92.1	1	75	5	5	121
SMB78	78V	78VC	86.7	106	1	78	5	4.3	139
SMB 78A	78VA	78VCA	86.7	95.8	1	78	5	4.8	126
SMB85	85V	85VC	94.4	115	1	85	5	4	151
SMB85A	85VA	85VCA	94.4	104	1	85	5	4.4	137
SMB90	90V	90VC	100	122	1	90	5	3.8	160
SMB90A	90VA	90VCA	100	111	1	90	5	4.1	146
SMB100	100V	100VC	111	136	1	100	5	3.4	179
SMB100A	100VA	100VCA	111	123	1	100	5	3.7	162
SMB110	110V	110VC	122	149	1	110	5	3.1	196
SMB110A	110VA	110VCA	122	135	1	110	5	3.4	177
SMB120	120V	120VC	133	163	1	120	5	2.8	214
SMB 120A	120VA	120VCA	133	157	1	120	5	3.1	193
SMB130	130V	130VC	144	176	1	130	5	2.6	231
SMB130A	130VA	130VCA	144	159	1	130	5	2.9	209
SMB150	150V	150VC	167	204	1	150	5	2.2	268
SMB150A	150VA	150VCA	167	185	1	150	5	2.5	243
SMB160	160V	160VC	178	218	1	160	5	2.1	287
SMB160A	160VA	160VCA	178	197	1	160	5	2.3	259
SMB170	170V	170VC	189	231	1	170	5	2	304
SMB170A	170VA	170VCA	189	209	1	170	5	2.2	275

Notes:

- (1) V_(BR) measured after I_T applied for 300 μ s I_T =square wave pulse or equivalent
- (2) Surge current waveform per Figure 3 and derate per Fig.2
- (3) For bidirectional types having V_{WM} of 10 volts and less, the I_D limit is doubled
- (4) All terms and symbols are consistent with ANSI/IEEE C62.35



SURFACE MOUNT TRANSIENT VOLTAGE SUPPRESSOR

SMB5.0 THRU SMB170CA

Stand-off Voltage 5.0 to 170 Volts

Peak Pulse Power 600 Watts

RATING AND CHARACTERISTIC CURVES SMB5.0 THRU SMB170CA

