

Space-saving Dual Output Signal Conditioners Mini-MW Series

(Configurator software is used to change the input type and precise range.)

LINEARIZER

(PC programmable)

Functions & Features

- Accepting non-linear input and providing a linearized output, proportional to the process variables
- 101-point calibration
- PC programmable
- High-density mounting

Typical Applications

- V-notch weir
- Gas analyzer
- Irregular-shaped tank level input for volume calculation
- Square root extracting for DP transmitter

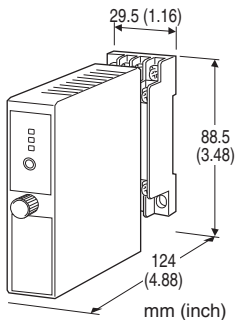

MODEL: W2XF-[1][2][3]-[4][5]

ORDERING INFORMATION

• Code number: W2XF-[1][2][3]-[4][5]

Specify a code from below for each [1] through [5].

(e.g. W2XF-S2Z1V3-M2/N/Q)

- Input range (e.g. 1 - 5 V DC)
- Output 1 range (e.g. 4 - 20 mA DC)
- Output 2 range (e.g. 1 - 5 V DC)
- Specify the specification for option code /Q (e.g. /C01/S01/SET)

Note: If one of the outputs should be a current range, specify it for the Output 1 to allow a greater load.

[1] INPUT

Current

Z1: Range 0 - 50 mA DC (Input resistance 24.9 Ω)

Voltage

S1: Range -1 - +1 V DC (Input resistance 1 MΩ min.)

S2: Range -10 - +10 V DC (Input resistance 1 MΩ min.)

[2] OUTPUT 1

Current

Z1: Range 0 - 20 mA DC

Voltage

V2: Range -10 - +10 V DC

V3: Range -5 - +5 V DC

[3] OUTPUT 2

Same range availability as Output 1

Y: None

(Configurator software is used to change output over the described range of the selected suffix code.

For changing between suffix codes, set the Output Range Selector on the side of unit before software adjustment.)

[4] POWER INPUT

AC Power

M2: 100 - 240 V AC (Operational voltage range 85 - 264 V, 47 - 66 Hz)

DC Power

R: 24 V DC

(Operational voltage range 24 V ±10 %, ripple 10 %p-p max.)

[5] OPTIONS (multiple selections)

Standards & Approvals (must be specified)

/N: Without CE

Other Options

blank: none

/Q: Option other than the above (specify the specification)

SPECIFICATIONS OF OPTION: Q (multiple selections)

COATING (For the detail, refer to M-System's web site.)

/C01: Silicone coating

/C02: Polyurethane coating

/C03: Rubber coating

TERMINAL SCREW MATERIAL

/S01: Stainless steel

EX-FACTORY SETTING

/SET: Preset according to the Ordering Information Sheet (No. ESU-5507)

RELATED PRODUCTS

- PC configurator software (model: W2CFG)

Downloadable at M-System's web site.

A dedicated cable is required to connect the module to the PC. Please refer to the internet software download site or the users manual for the PC configurator for applicable

cable types.

GENERAL SPECIFICATIONS

Construction: Plug-in

Connection: M3 screw terminals (torque 0.8 N·m)

Screw terminal: Chromated steel (standard) or stainless steel

Housing material: Flame-resistant resin (black)

Isolation: Input to output 1 to output 2 to power

Overrange output: -15 to +115 %

(Negative current output is not available.)

Zero adjustment: -5 to +5 % (PC programming)

Span adjustment: 95 to 105 % (PC programming)

Programming: Downloaded from PC; input range, output range, zero and span,

response time, linearization table, simulating output, etc.

Linearization: 101 points max. within the range of -15 - +115 % input or output; represented as percentage of full-scale (No table setting is done at shipping. [gain = 1])

Status indicator LED: Tri-color (green/amber/red) LED;

Blinking patterns indicate operation status of the transmitter.

Configurator connection: 2.5 dia. miniature jack; RS-232-C level

INPUT SPECIFICATIONS

■ **DC Current:** Input resistor incorporated
(If not specified, the input range is 4 - 20 mA DC.)

Input range: 0 - 50 mA DC

Minimum span: 2 mA

Offset: Lower range can be any specific value within the input range provided that the minimum span is maintained.

■ **DC Voltage**

Code S1 (narrow spans)

Input range: -1 - +1V DC

Minimum span: 100 mV

Code S2 (wide spans)

Input range: -10 - +10 V DC

Minimum span: 1 V

Offset: Lower range can be any specific value within the input range provided that the minimum span is maintained.

If not specified, the input range is shown below.

S1: 0 - 100 mV DC

S2: 1 - 5 V DC

OUTPUT SPECIFICATIONS

■ **DC Current**

Operational range: 0 - 23 mA DC

Minimum span: 1 mA

Offset: Lower range can be any specific value within the output range provided that the minimum span is

maintained.

Load resistance: Output drive 12 V max. for Output 1; 7 V max. for Output 2

(e.g. 4 - 20 mA: 600 Ω [12 V ÷ 20 mA])

If not specified, the output range is 4 - 20 mA DC.

■ **DC Voltage**

Code V2 (wide spans)

Operational range: -11.5 - +11.5 V DC

Minimum span: 1 V

Code V3 (narrow spans)

Operational range: -6 - +6 V DC

Minimum span: 0.5 V

Offset: Lower range can be any specific value within the output range provided that the minimum span is maintained.

Load resistance: Output drive 1 mA max.

(e.g. 1 - 5 V: 5000 Ω [5 V ÷ 1 mA])

If not specified, the output range is shown below.

V2: 0 - 10 V DC

V3: 1 - 5 V DC

INSTALLATION

Power Consumption

• **AC:**

Approx. 5 VA at 100 V

Approx. 6 VA at 200 V

Approx. 7 VA at 264 V

• **DC:** Approx. 3 W

Operating temperature: -5 to +55°C (23 to 131°F)

Operating humidity: 30 to 90 %RH (non-condensing)

Mounting: Surface or DIN rail

Weight: 150 g (0.33 lb)

PERFORMANCE in percentage of span

Overall accuracy:

Input accuracy + output accuracy [gain ≤ 1]

(inp. accuracy + out. accuracy) × gain [gain > 1]

Inversely proportional to the span.

See CALCULATION EXAMPLES OF OVERALL ACURACY.

• **Input accuracy:** (% of max. input range)

-1 - +1 V : ±0.01 %

-10 - +10 V : ±0.01 %

0 - 50 mA : ±0.02 %

• **Output accuracy:** ±0.04 % of max. output range

Temp. coefficient: ±0.015 %/°C (±0.008 %/°F) of max. span at -5 to +55°C [23 to 131°F]

Response time: (0 - 90 %)

Standard: ≤ 500 msec.

Fast: ≤ 25 msec.

Line voltage effect: ±0.1 % over voltage range

Insulation resistance: ≥ 100 MΩ with 500 V DC

Dielectric strength: 2000 V AC @1 minute (input to output
1 to output 2 to power to ground)

CALCULATION EXAMPLES OF OVERALL ACCURACY

[Example] Input Type -10 - +10 V, Input Range 1 - 5 V,
Output Type 0 - 20 mA, Output Range 4 - 20 mA
Max. Input Range (20 V) ÷ Span (4 V) × 0.01 % = 0.05 %
Max. Output Range (20 mA) ÷ Span (16 mA) × 0.04 %
= 0.05 %
Overall accuracy = 0.05 + 0.05 = ±0.10 %

EXTERNAL VIEW

FRONT VIEW

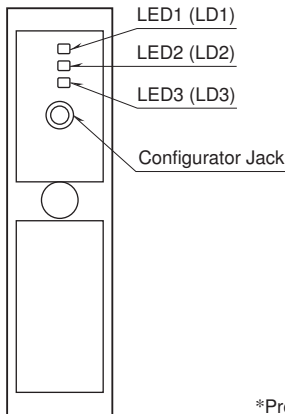

SIDE VIEW

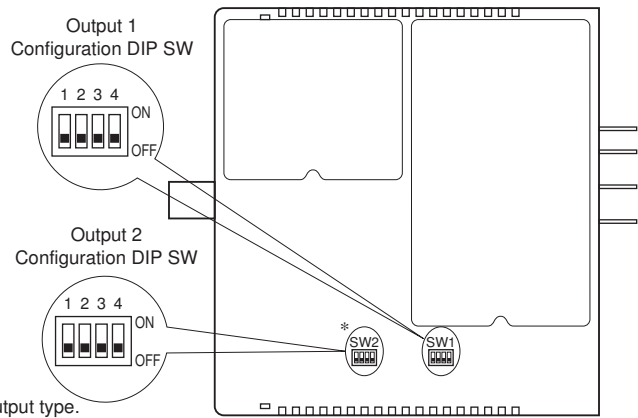

Refer to the instruction manual for detailed procedures.

EXTERNAL DIMENSIONS & TERMINAL ASSIGNMENTS unit: mm (inch)

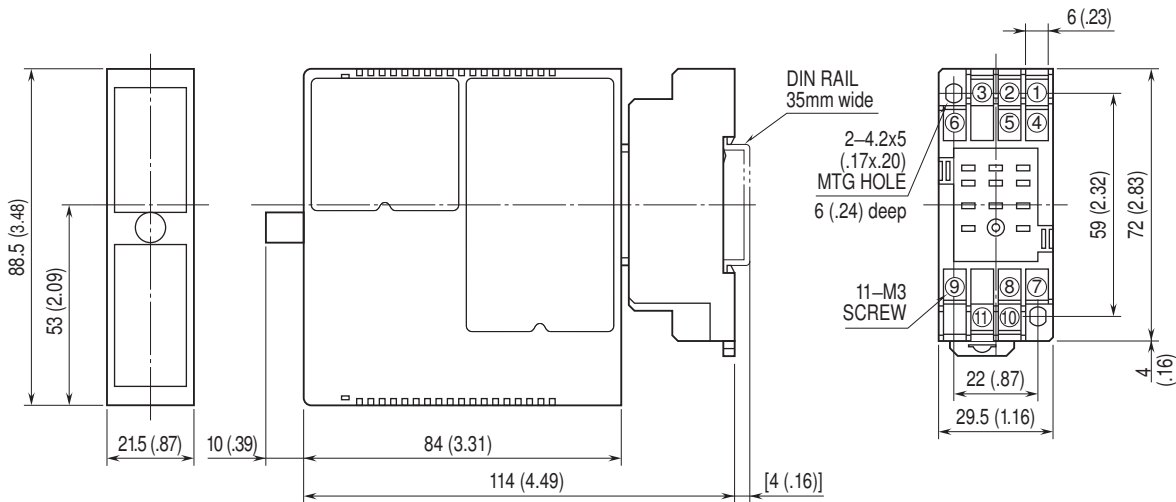

• When mounting, no extra space is needed between units.

SCHEMATIC CIRCUITRY & CONNECTION DIAGRAM

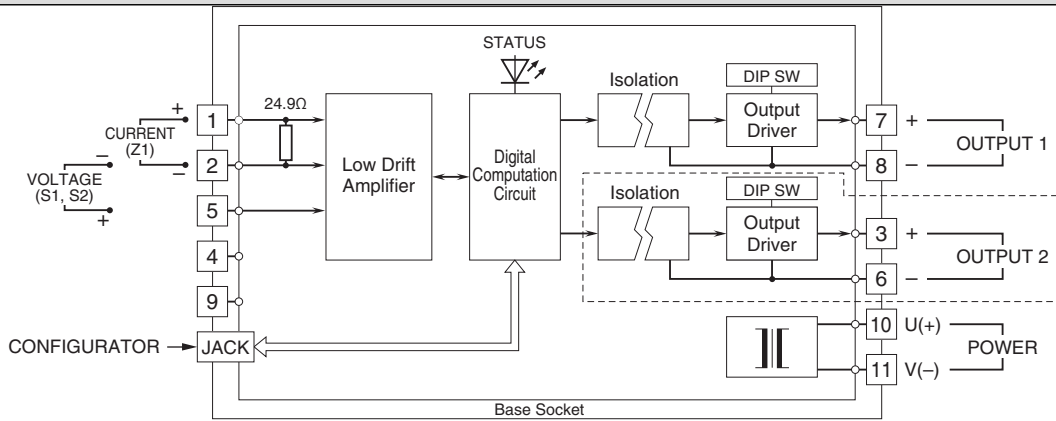

Remark: The section enclosed by broken line is only with 2nd output option.



Specifications are subject to change without notice.