

**1.0A SURFACE MOUNT GLASS PASSIVATED BRIDGE**

**RECTIFIER Reverse Voltage - 100 to 1000 V**

**Forward Current – 1.0A**

**FEATURES**

- ◆Fast reverse recovery time
- ◆Designed for Surface Mount Application
- ◆Glass Passivated Chip Junction
- ◆Low power loss, high efficiency
- ◆Lead free in comply with EU RoHS 2011/65/EU directives

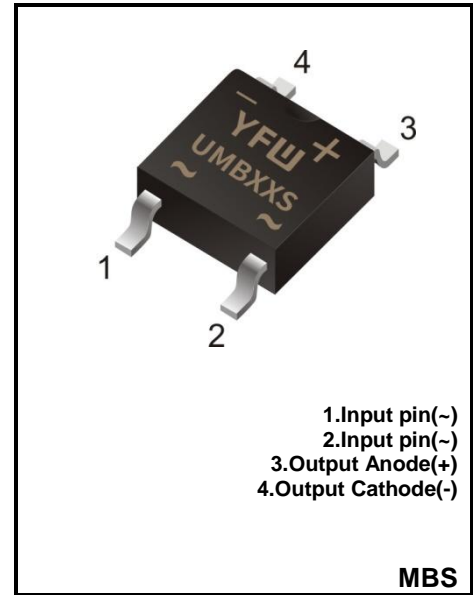

**MECHANICAL DATA**

- ◆Case: MBS
- ◆Terminals: Solderable per MIL-STD-750, Method 2026
- ◆Approx. Weight: 100mg / 0.0035oz

**Maximum Ratings and Electrical characteristics**

Ratings at 25 °C ambient temperature unless otherwise specified.

Single phase half-wave 60 Hz, resistive or inductive load, for capacitive load current derate by 20 %.

Parameter	Symbols	UMB1S	UMB2S	UMB4S	UMB6S	UMB8S	UMB10S	Units
Maximum Repetitive Peak Reverse Voltage	$V_{RRM}$	100	200	400	600	800	1000	V
Maximum RMS voltage	$V_{RMS}$	70	140	280	420	560	700	V
Maximum DC Blocking Voltage	$V_{DC}$	100	200	400	600	800	1000	V
Average Rectified Output Current at $T_c = 125\text{ }^\circ\text{C}$	$I_o$	1.0						A
Peak Forward Surge Current 8.3 ms Single Half Sine-Wave Superimposed on Rated Load(JEDEC method)	$I_{FSM}$	35						A
Forward Voltage per element at 1.0A	$V_F$	1.0		1.3		1.5		V
Maximum DC Reverse Current @ $T_A=25\text{ }^\circ\text{C}$ at Rated DC Blocking Voltage @ $T_A=125\text{ }^\circ\text{C}$	$I_R$	5.0 100						$\mu\text{A}$
Typical Junction Capacitance <sup>(Note1)</sup>	$C_j$	18						pF
Maximum Reverse Recovery Time <sup>(Note2)</sup>	$T_{RR}$	50			75			nS
Typical Thermal Resistance <sup>(Note3)</sup>	$R_{\theta JA}$ $R_{\theta JC}$	80 30						$^\circ\text{C/W}$
Operating and Storage Temperature Range	$T_j, T_{stg}$	-55 ~ +150						$^\circ\text{C}$

(1) Measured at 1 MHz and applied reverse voltage of 4 V D.C

(2) Mounted on glass epoxy PC board with 4x1.5"x1.5" (3.81x3.81 cm) copper pad.

**Fig.1 Reverse Recovery Time Characteristic And Test Circuit Diagram**

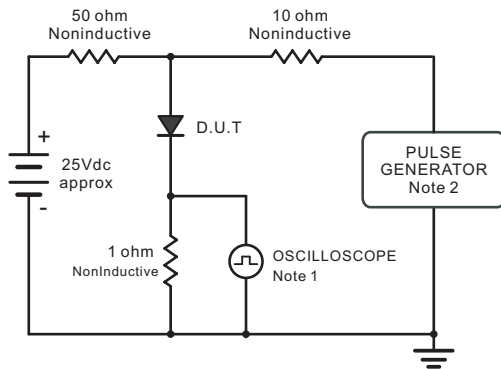

Note: 1. Rise Time = 7ns, max.  
Input Impedance = 1megohm, 22pF.  
2. Rise Time = 10ns, max.  
Source Impedance = 50 ohms.

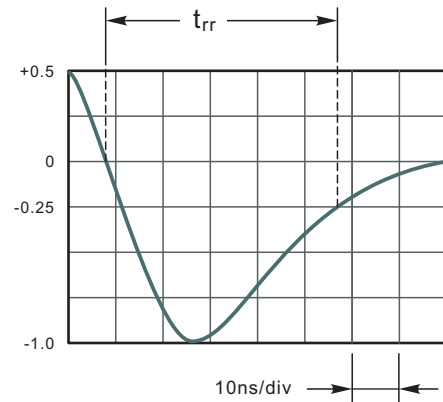

Set time Base for 10ns/div

**Fig.2 Maximum Average Forward Current Rating**

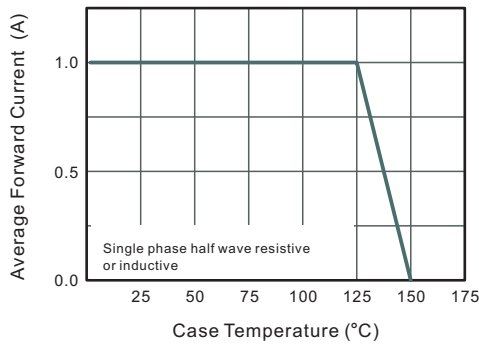

**Fig.3 Typical Reverse Characteristics**

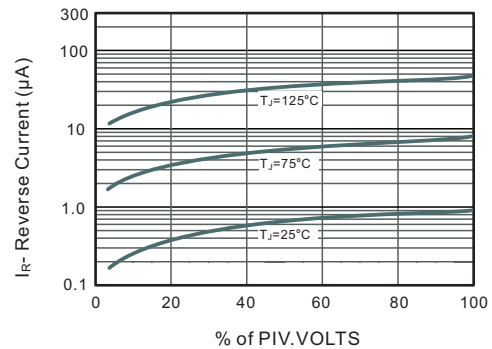

**Fig.3 Typical Instaneous Forward Characteristics**

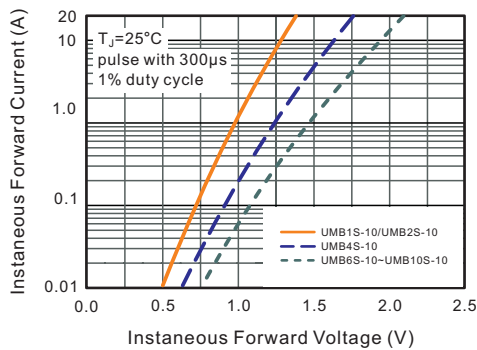

**Fig.4 Maximum Non-Repetitive Peak Forward Surge Current**

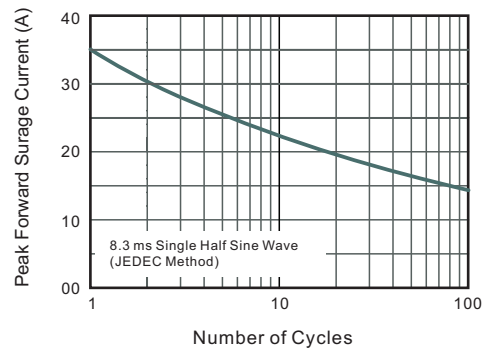

**Package Outline**

**MBS**

Plastic surface mounted package; 4 leads

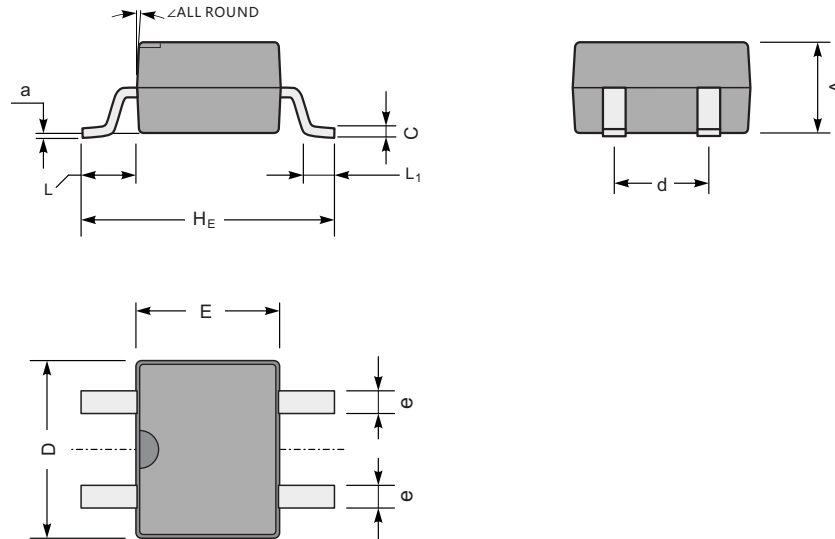

UNIT		A	C	D	E	HE	d	e	L	L1	a	∠
mm	max	2.6	0.22	5.0	4.1	7.0	2.7	0.7	1.7	1.1	0.2	7°
	min	2.2	0.15	4.5	3.6	6.4	2.3	0.5	1.3	0.5	—	
mil	max	102	8.7	197	161	276	106	28	67	43	8	
	min	94	5.9	177	142	252	91	20	51	20	—	

**The recommended mounting pad size**

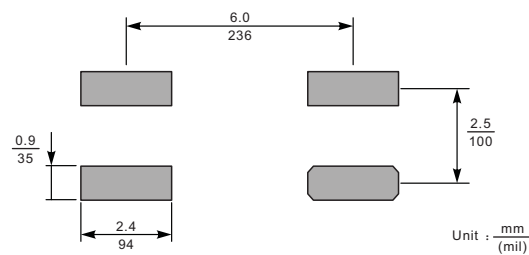

**Summary of Packing Options**

Package	Packing Description	Packing Quantity	Industry Standard
MBS	Tape/Reel, 13" reel	3000	EIA-481-1