

SOLIDWORKS GENERATED DRAWING, DO NOT CHANGE BY HAND

REV.	ECN. NO.	APPD.
A	BC-13-0069770	C.S Li
B	BC-14-0031202	C.S Li
C	BC-14-0038912	C.S Li
D	BC-14-0054778	C.S Li

- NOTES:
- ELECTRICAL CHARACTERISTICS:
    - CONTACT CURRENT RATING: 0.5 AMPERE MAX. PER PIN.
    - VOLTAGE RATING: 25V AC.
    - INSULATION RESISTANCE: 100 MEGAOHMS MIN. AT 500V DC.
    - DIELECTRIC WITHSTANDING VOLTAGE: 250V AC RMS AT 60Hz, FOR 1 MINUTE.
    - CONTACT RESISTANCE: 60 MILLIOHMS MAX. PER PIN INITIAL  
 $\Delta$ 10 MILLIOHMS PER PIN AFTER FULL ENVIRONMENTAL TESTING.
  - MECHANICAL CHARACTERISTICS: DURABILITY: 60 MATING CYCLES.
  - OPERATION TEMPERATURE: -55 °C TO +85 °C.
  - RECOMMENDED PROCESS CONDITION: SMT, PEAK TEMPERATURE: 260 °C 10~20S.
  - PLEASE CONTACT FOXCONN SALES REPRESENTATIVE TO VERIFY PRODUCT DETAILS & AVAILABILITY.

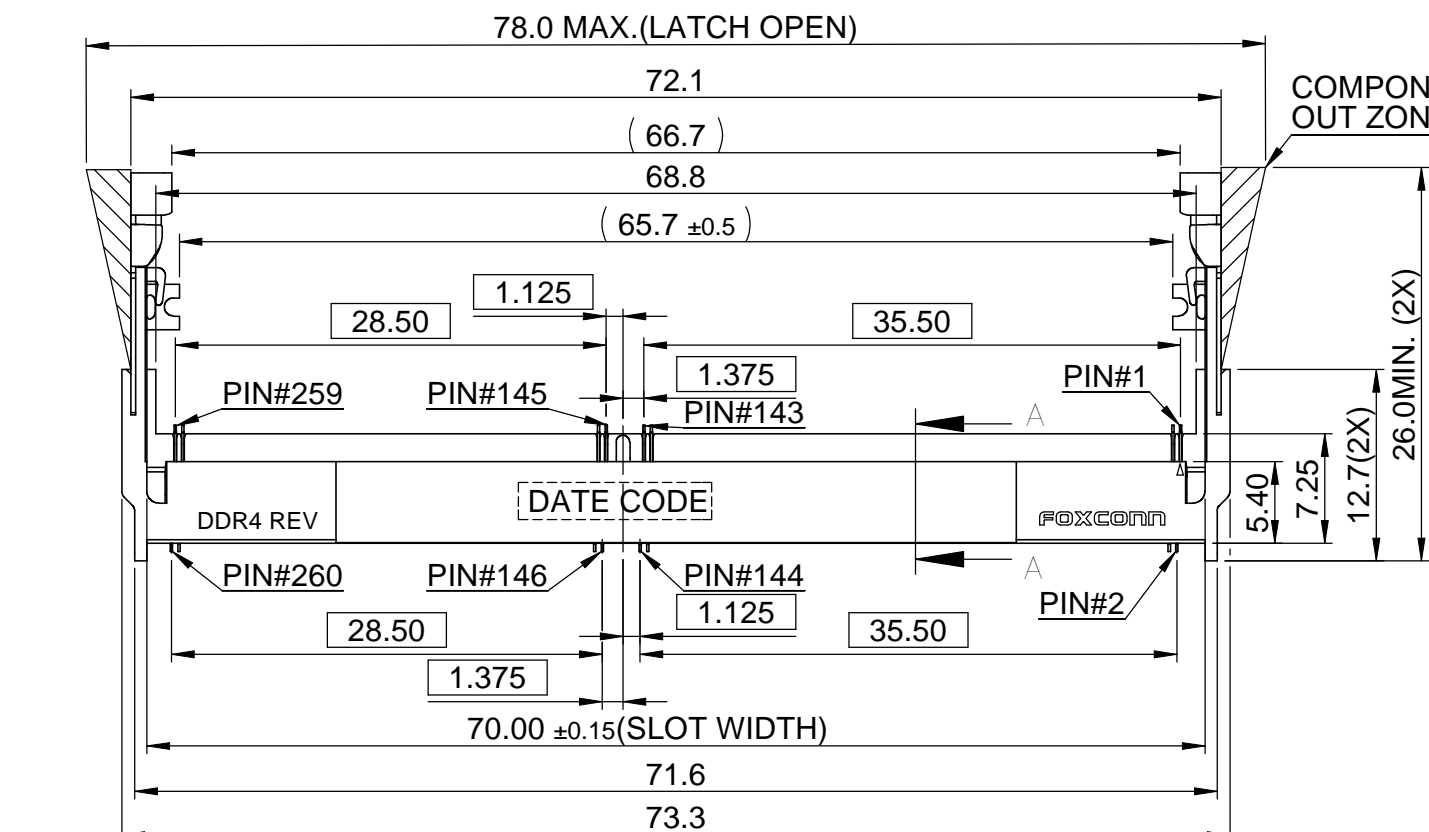
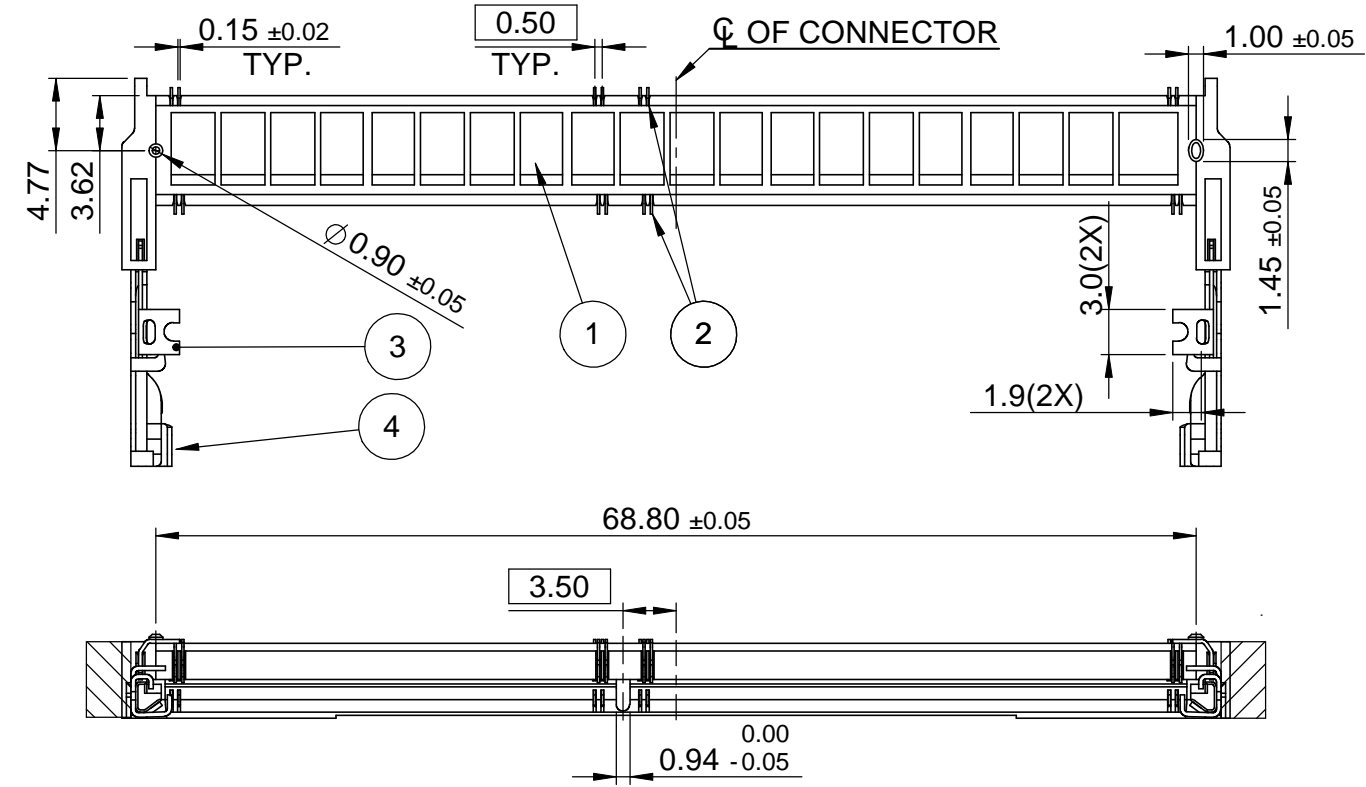

ITEM	DESCRIPTION	Q'TY	MATERIAL	TREATMENT
4	METAL SPRING	2	STAINLESS STEEL	ULTRASONIC CLEANING
3	METAL PAD	2	STAINLESS STEEL	10u" NICKEL UNDER PLATING 100u" MATTE TIN PLATING OVER SOLDER PAD AREA
2	CONTACT	260	COPPER ALLOY	50u" NICKEL UNDER PLATING GOLD FLASH OR 5u" OR 10u" OR 15u" OR 30u" GOLD PLATING AT CONTACT AREA; GOLD FLASH PLATING AT TAIL
1	HOUSING	1	THERMOPLASTIC	UL94V-0, HALOGEN FREE, BLACK COLOR

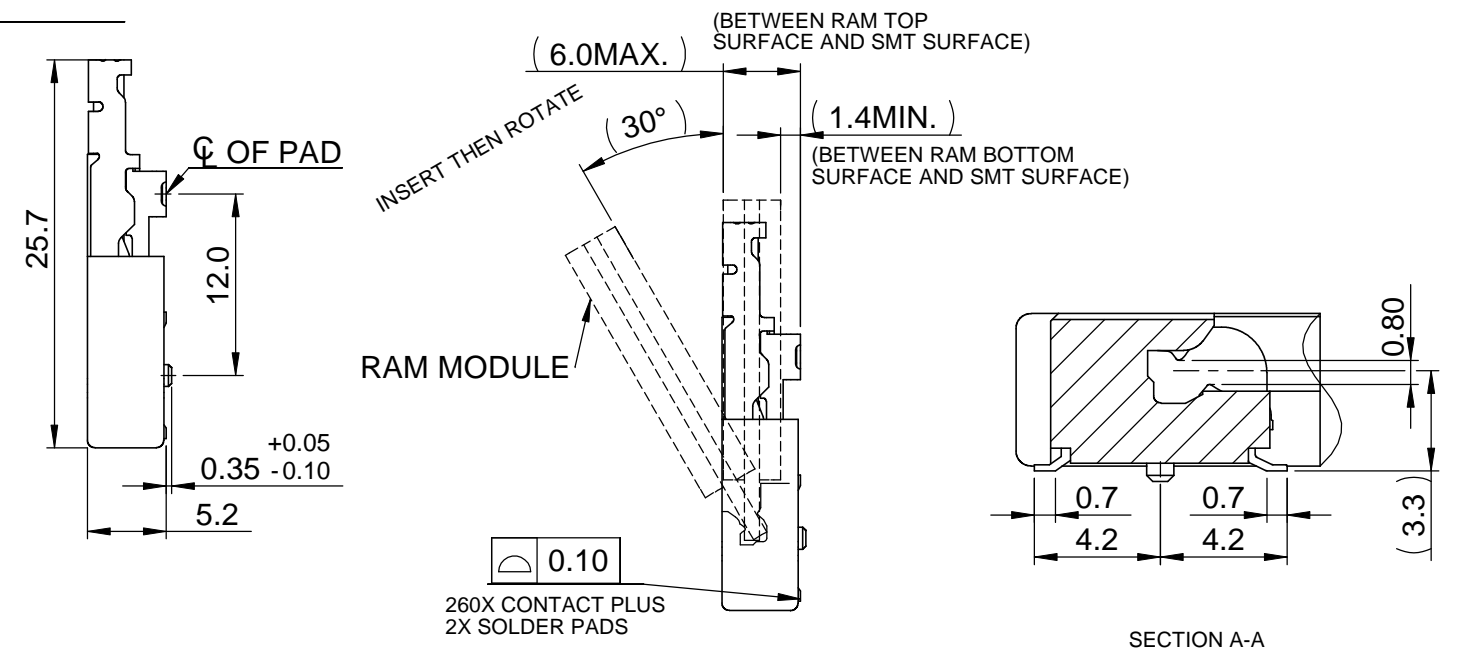
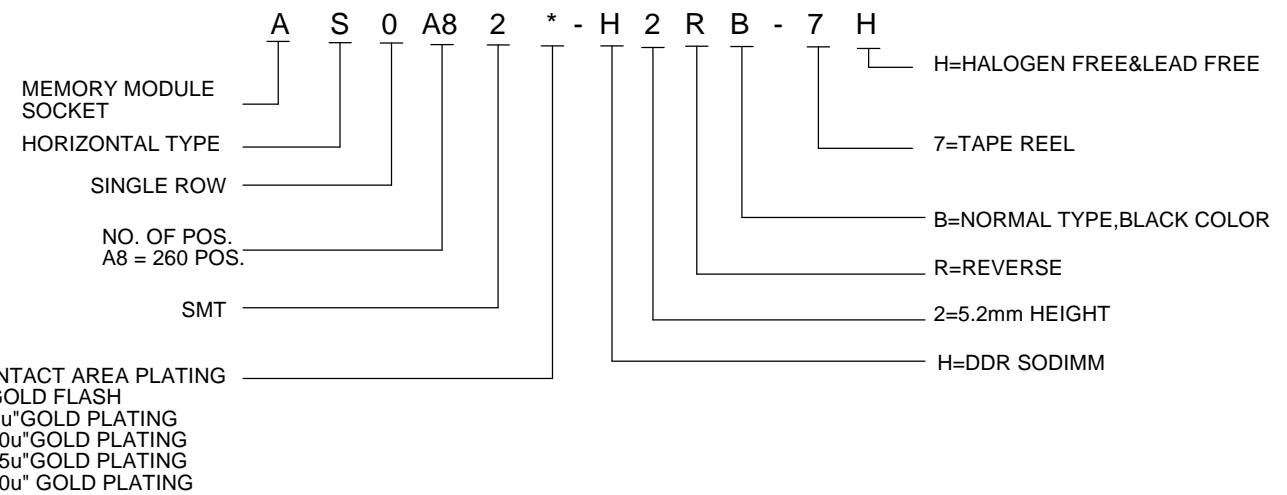

UNIT	VALUE	UNIT	VALUE	UNITS	mm	NAME (INTENDED USE)	FOXCONN®
X. ±	0.30	X. °		UNITS	mm	DDR4 SO DIMM CONN.	FOXCONN INTERCONNECT TECHNOLOGY LIMITED.
.X ±	0.25	.X °		MAT'L		PART NO. (INTENDED USE)	CLASS: <input type="checkbox"/> CONFIDENTIAL <input type="checkbox"/> SECRET <input checked="" type="checkbox"/> GENERAL
.XX ±	0.15	.XX °		FINISH		AS0A82*-H2RB-7H	TITLE: CUSTOMER DRAWING 260PIN SODDDR4 5.2 REV.
.XXX ±		.XXX °		Q'TY		APPD: C.S Li	DWG NO.: 317-0000-2253
THESE DRAWINGS AND SPECIFICATIONS ARE THE PROPERTY OF FOXCONN INTERCONNECT TECHNOLOGY LIMITED. AND SHALL NOT BE REPRODUCED, COPIED OR USED IN ANY MANNER WITHOUT THE PRIOR WRITTEN CONSENT OF FOXCONN INTERCONNECT TECHNOLOGY LIMITED.						CHKD: Alex Wang	
						DRAW: Gary Xu 2014/9/24	

REV.	ECN. NO.	APPD.

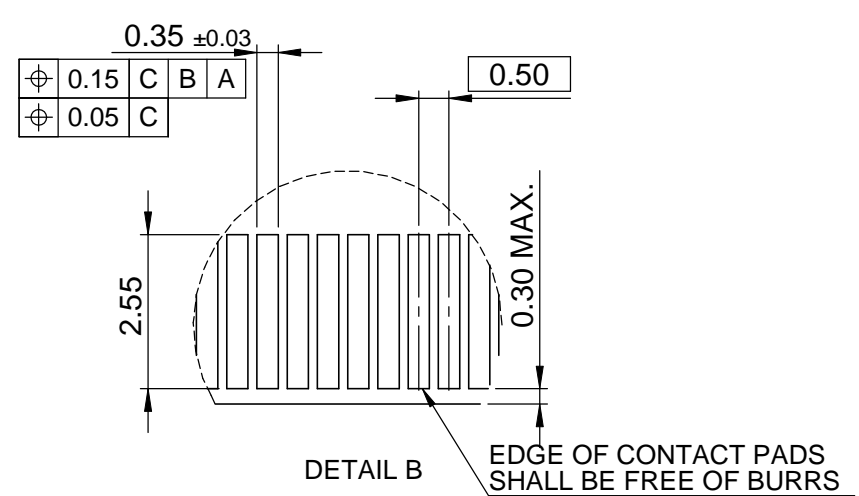
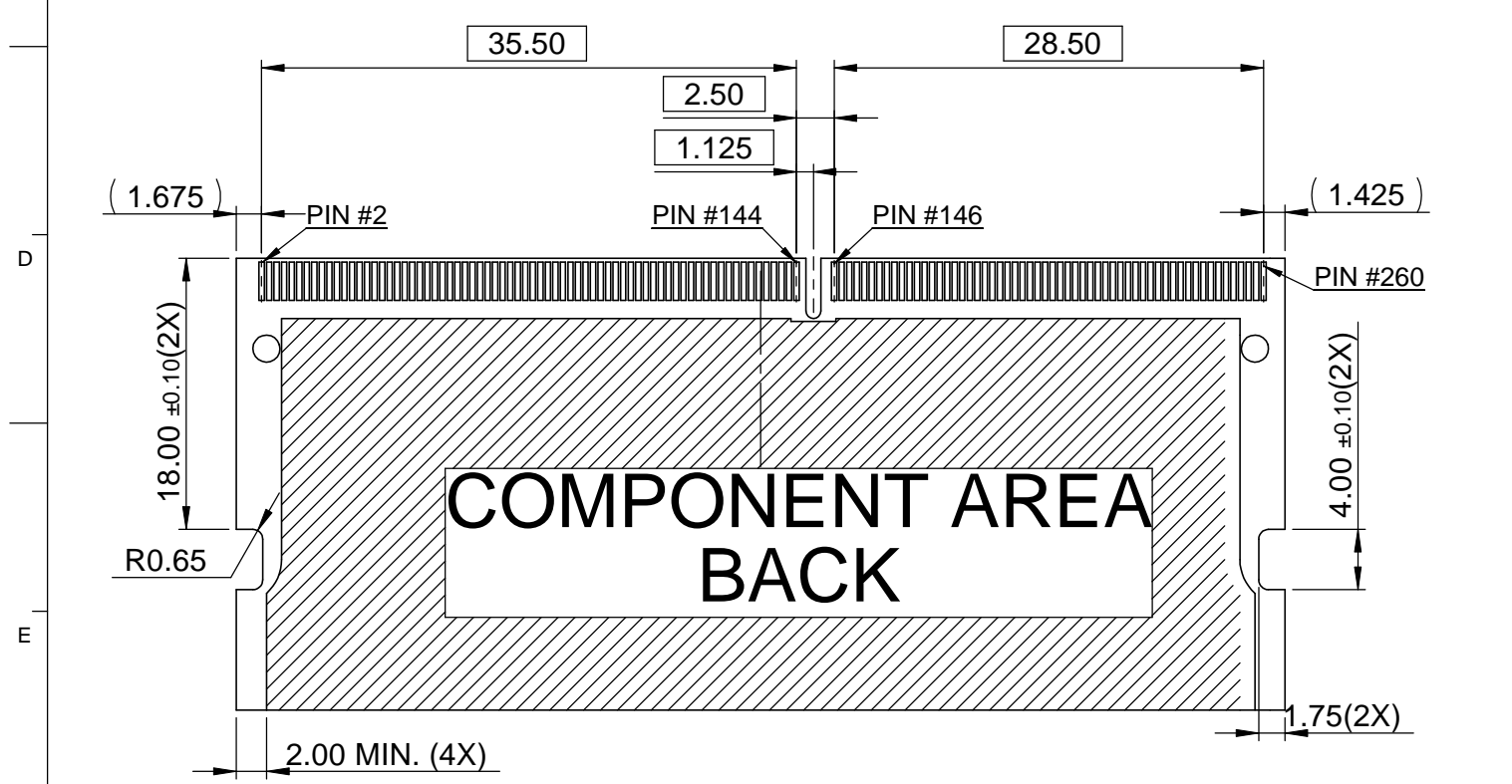
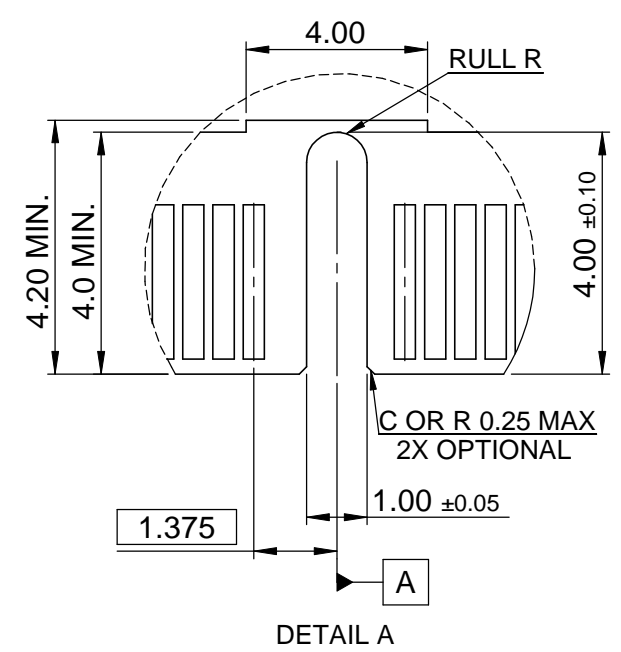
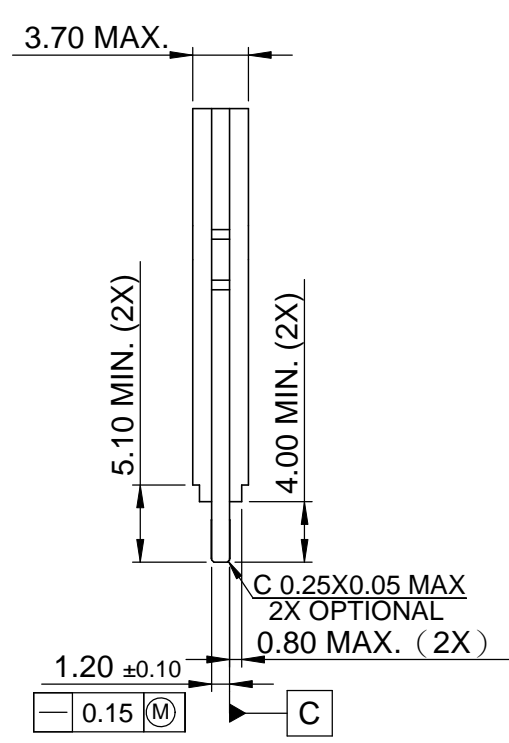
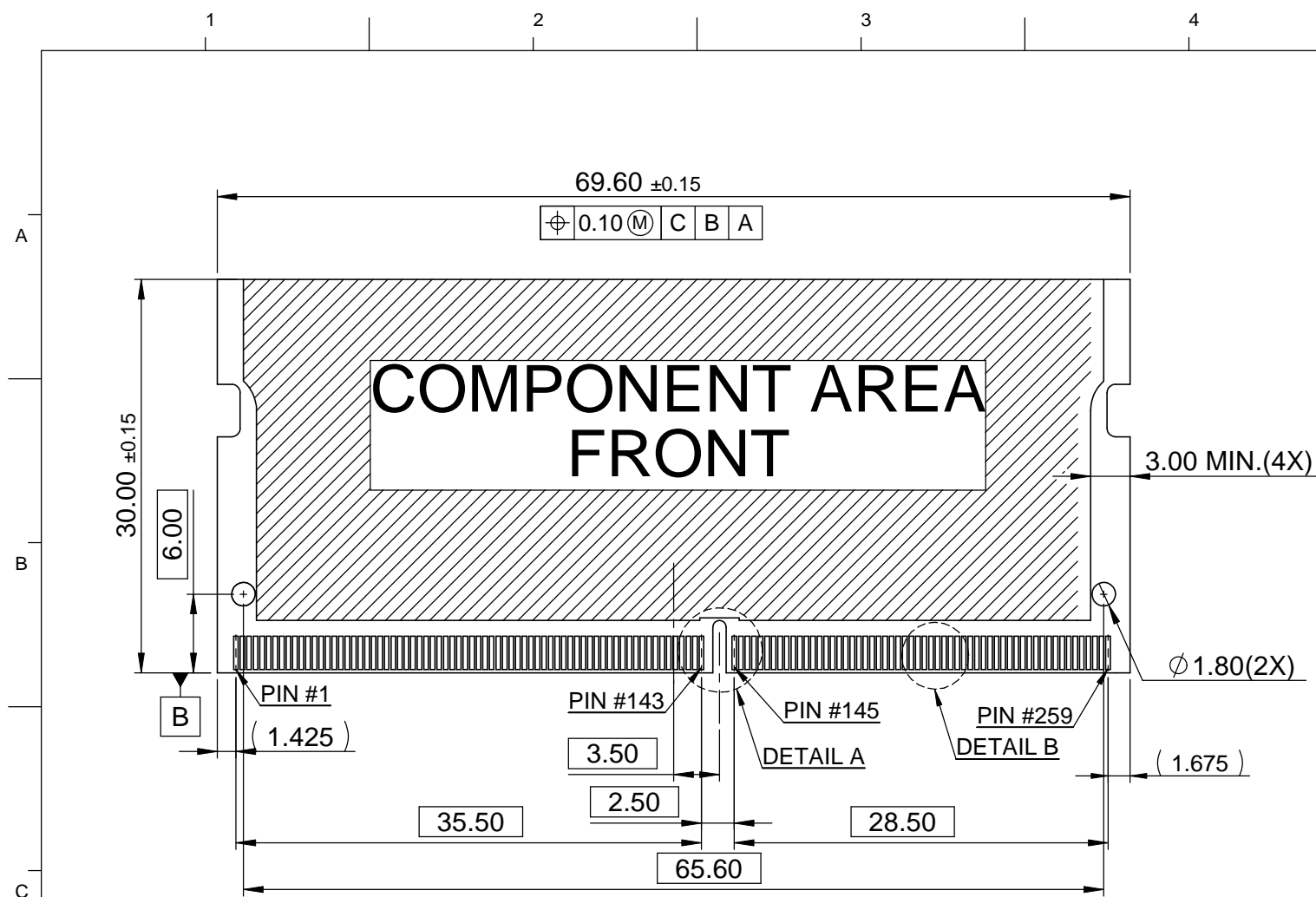

DDRIV SO DIMM MODULE BOARD LAYOUT

X.± 0.25	X° ±	UNITS mm	NAME (INTENDED USE)	<b>FOXCONN®</b> FOXCONN INTERCONNECT TECHNOLOGY LIMITED.						
.X± 0.10	.X° ±		DDR4 SO DIMM CONN.							
.XX ± 0.05	.XX° ±	MAT'L	PART NO. (INTENDED USE)	CLASS: <input type="checkbox"/> CONFIDENTIAL <input type="checkbox"/> SECRET <input checked="" type="checkbox"/> GENERAL						
.XXX ±	.XXX° ±		AS0A82*-H2RB-7H	TITLE: CUSTOMER DRAWING 260PIN SODDR4 5.2 REV.						
THESE DRAWINGS AND SPECIFICATIONS ARE THE PROPERTY OF FOXCONN INTERCONNECT TECHNOLOGY LIMITED. AND SHALL NOT BE REPRODUCED, COPIED OR USED IN ANY MANNER WITHOUT THE PRIOR WRITTEN CONSENT OF FOXCONN INTERCONNECT TECHNOLOGY LIMITED.		FINISH	APPD: C.S Li	DWG NO.: 317-0000-2253						
			QTY	CHKD: Alex Wang	<table border="1"> <tr> <td>SCALE</td> <td>SHEET</td> <td>REV.</td> </tr> <tr> <td>N/A</td> <td>2/5</td> <td>D</td> </tr> </table>	SCALE	SHEET	REV.	N/A	2/5
SCALE	SHEET	REV.								
N/A	2/5	D								
			DRAW: Gary Xu 2014/9/24							

REV.	ECN. NO.	APPD.

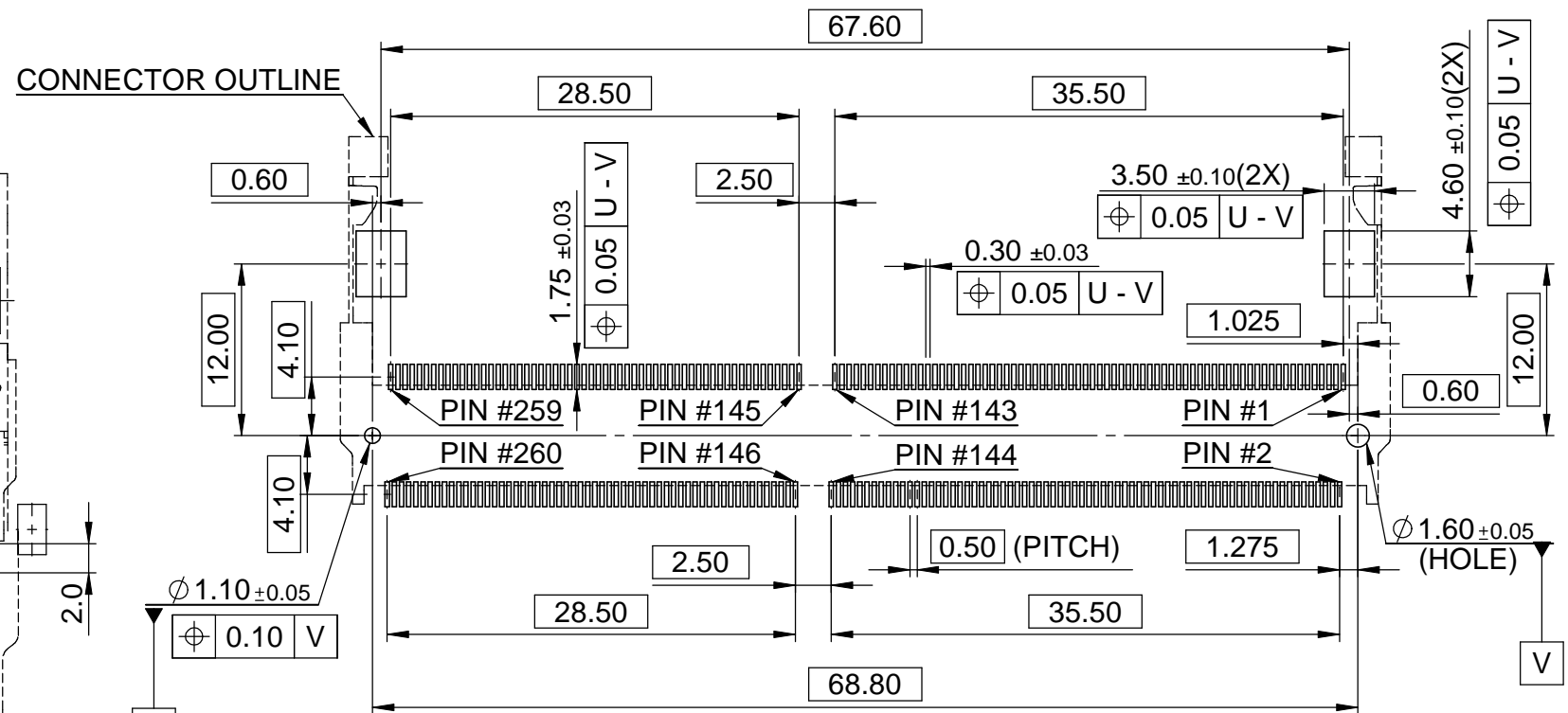
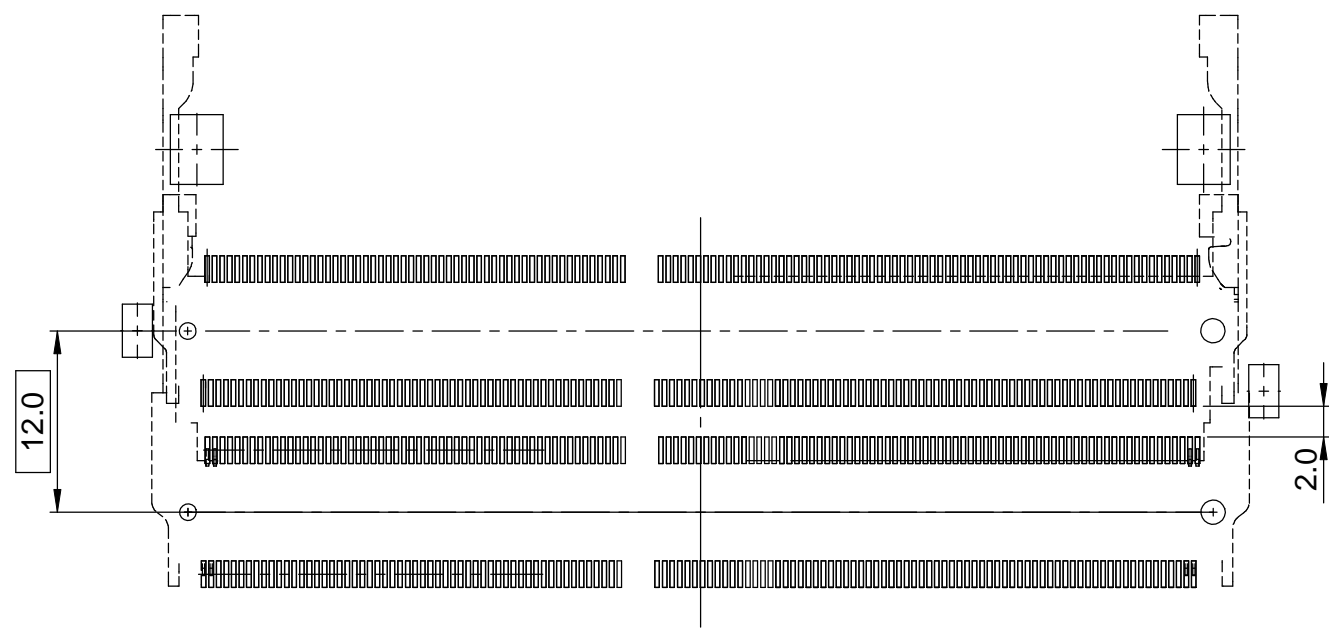
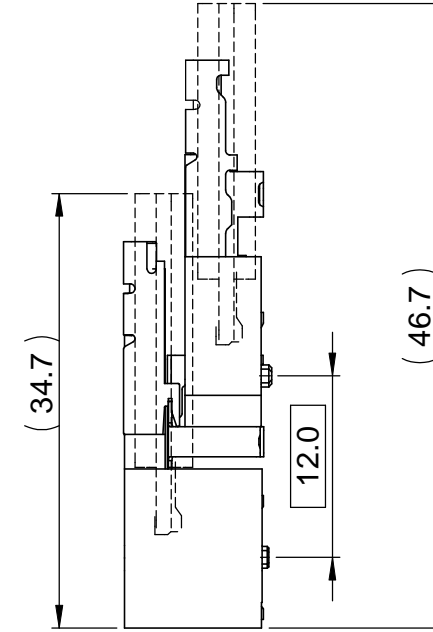

P.C.B. LAYOUT(STACKED ORIENTATION)

P.C.B. LAYOUT(RECOMMEND THICKNESS=1.40MM)

X.± 0.25	X° ±	UNITS mm	NAME (INTENDED USE)	<b>FOXCONN®</b> FOXCONN INTERCONNECT TECHNOLOGY LIMITED.
.X ± 0.10	.X° ±		DDR4 SO DIMM CONN.	
.XX ± 0.05	.XX° ±	MAT'L	PART NO. (INTENDED USE)	CLASS: <input type="checkbox"/> CONFIDENTIAL <input type="checkbox"/> SECRET <input checked="" type="checkbox"/> GENERAL
.XXX ±	.XXX° ±	FINISH	AS0A82*-H2RB-7H	TITLE: CUSTOMER DRAWING 260PIN SODDR4 5.2 REV.
THESE DRAWINGS AND SPECIFICATIONS ARE THE PROPERTY OF FOXCONN INTERCONNECT TECHNOLOGY LIMITED. AND SHALL NOT BE REPRODUCED, COPIED OR USED IN ANY MANNER WITHOUT THE PRIOR WRITTEN CONSENT OF FOXCONN INTERCONNECT TECHNOLOGY LIMITED.			APPD: C.S Li	DWG NO.: 317-0000-2253
			CHKD: Alex Wang	SCALE SHEET REV.
			DRAW: Gary Xu 2014/9/24	N/A 3/5 D

REV.	ECN. NO.	APPD.

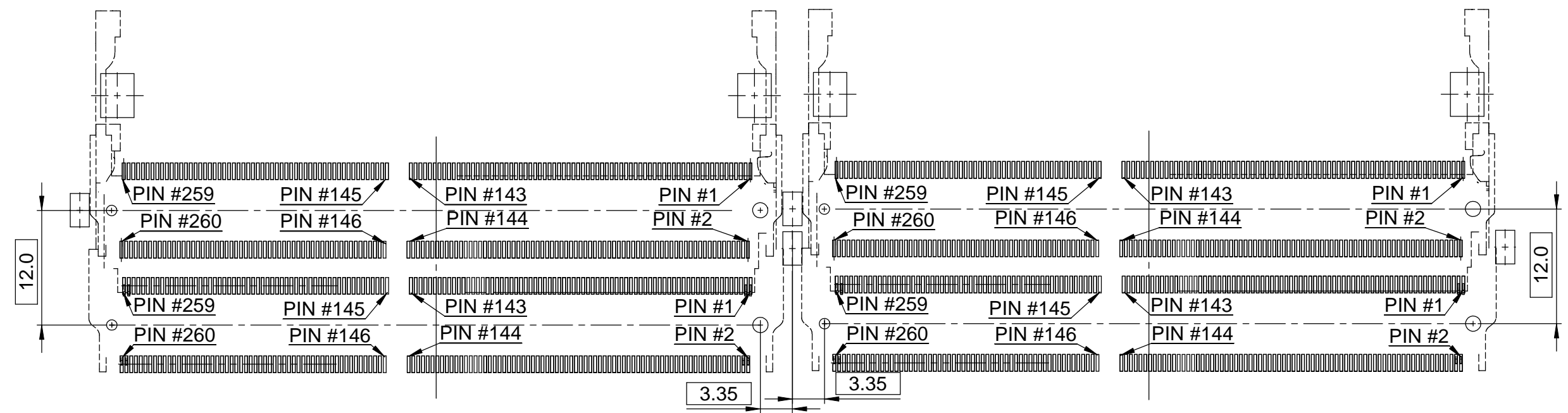
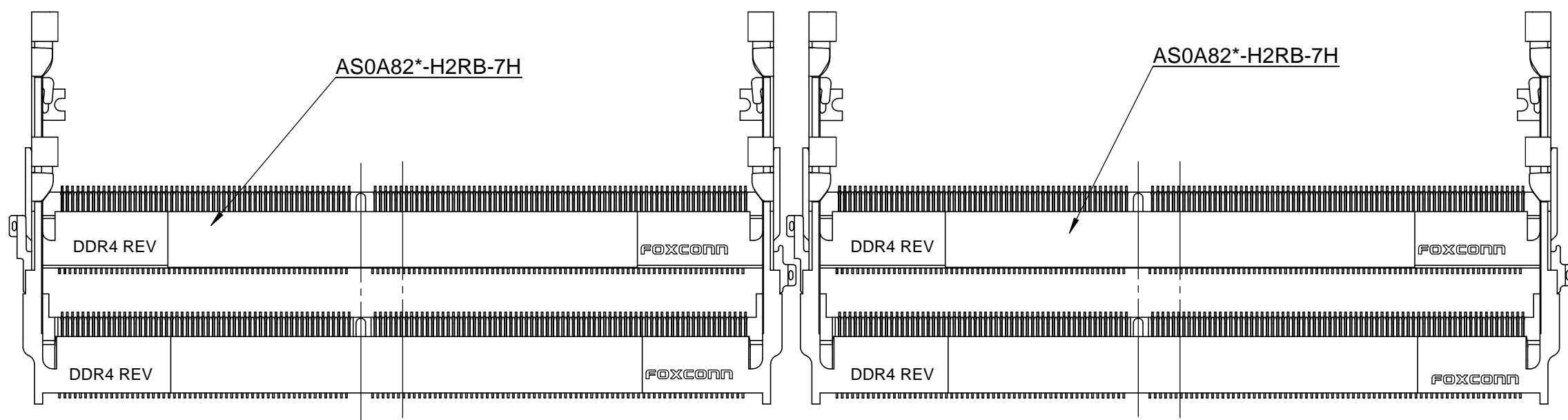

X.± 0.25	X° ±	UNITS mm	NAME (INTENDED USE)	<b>FOXCONN®</b> FOXCONN INTERCONNECT TECHNOLOGY LIMITED.						
.X ± 0.10	.X° ±		DDR4 SO DIMM CONN.							
.XX ± 0.05	.XX° ±		PART NO. (INTENDED USE)							
.XXX ±	.XXX° ±	FINISH	AS0A82*-H2RB-7H							
THESE DRAWINGS AND SPECIFICATIONS ARE THE PROPERTY OF FOXCONN INTERCONNECT TECHNOLOGY LIMITED. AND SHALL NOT BE REPRODUCED, COPIED OR USED IN ANY MANNER WITHOUT THE PRIOR WRITTEN CONSENT OF FOXCONN INTERCONNECT TECHNOLOGY LIMITED.		QTY	APPD: C.S Li		CLASS: <input type="checkbox"/> CONFIDENTIAL <input type="checkbox"/> SECRET <input checked="" type="checkbox"/> GENERAL TITLE: CUSTOMER DRAWING 260PIN SODDR4 5.2 REV.					
			CHKD: Alex Wang	DWG NO.: 317-0000-2253						
			DRAW: Gary Xu 2014/9/24	<table border="1"> <tr> <td>SCALE</td> <td>SHEET</td> <td>REV.</td> </tr> <tr> <td>N/A</td> <td>4/5</td> <td>D</td> </tr> </table>	SCALE	SHEET	REV.	N/A	4/5	D
SCALE	SHEET	REV.								
N/A	4/5	D								

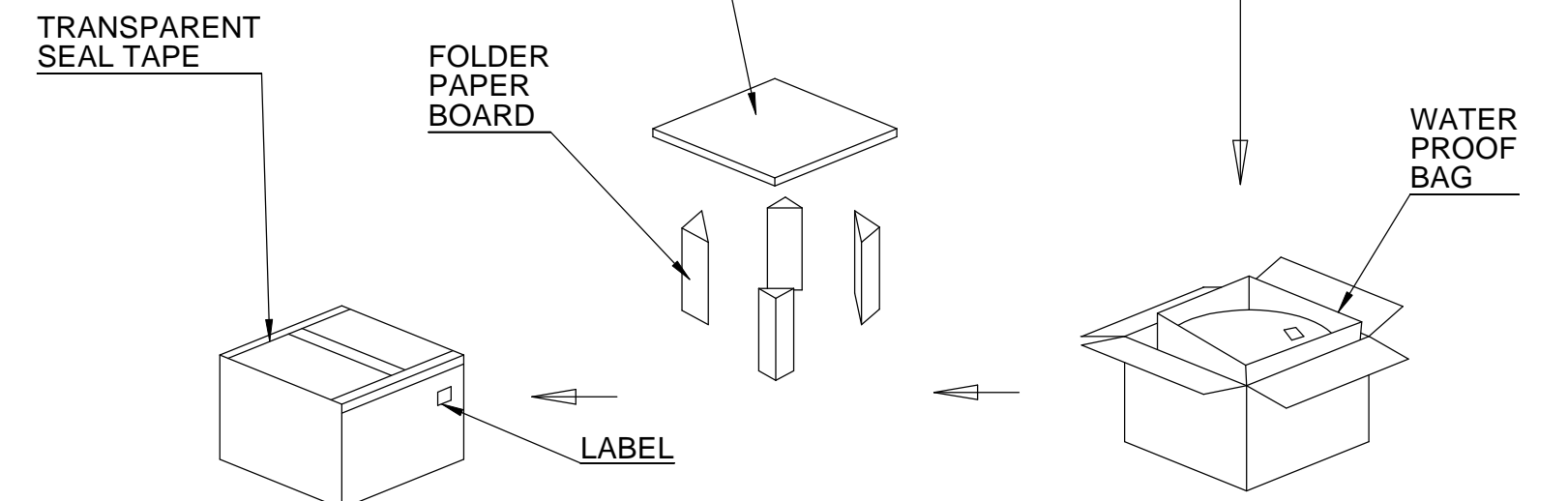
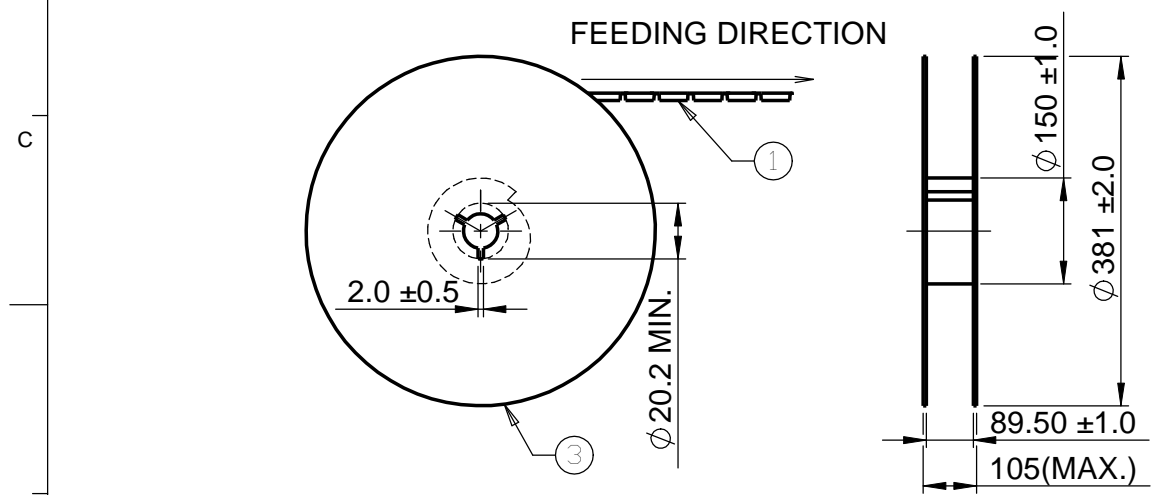
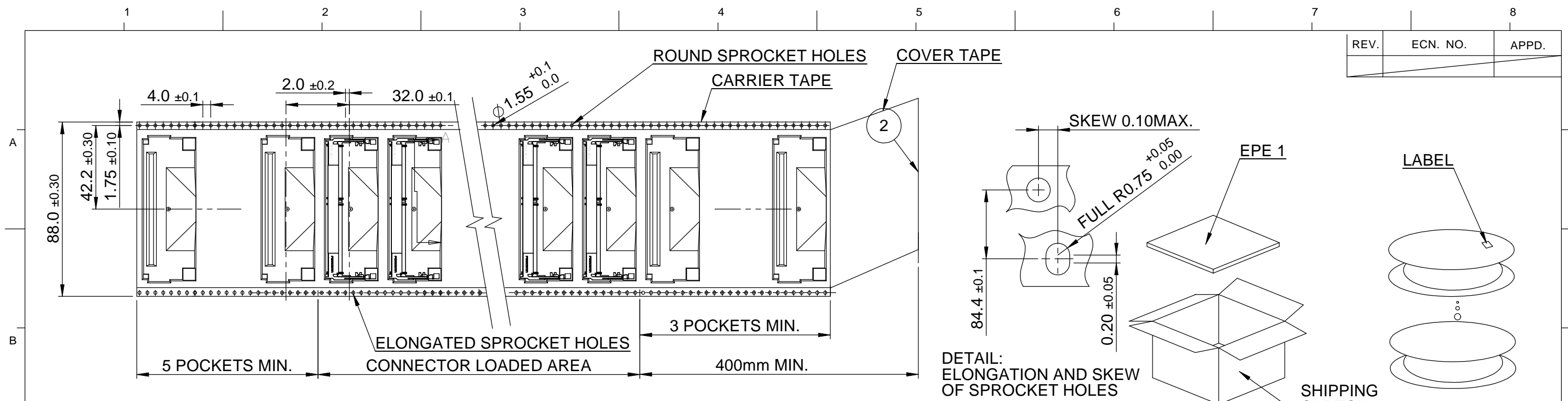

NOTES:  
 1. 10 POCKETS HOLE PITCH CUMULATIVE TOLERANCE  $\pm 0.20$ mm.  
 2. COVER TAPE PEELING STRENGTH : 0.01 kgf MIN. 0.15 kgf MAX. AT 300mm/min.

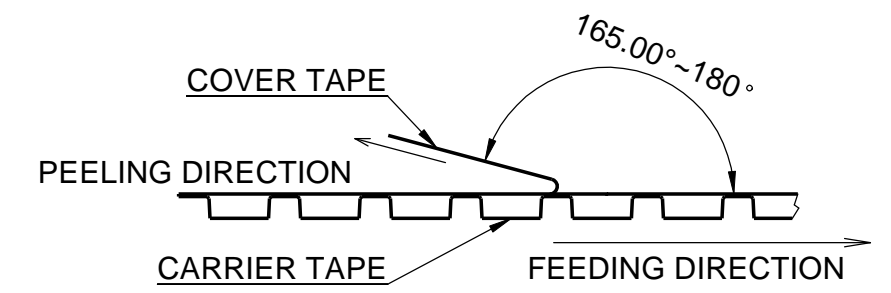

3. PACKING CAPACITY :310 PCS/REEL, 3 REELS/BOX, TOTAL 930 PCS/BOX.

CONNECTOR P/N AS0A82\*-H2RB-7H

ITEM	DESCRIPTION	MATERIAL
3	REEL	POLYSTYRENE
2	COVER TAPE	POLYESTER
1	CARRIER TAPE	POLYSTYRENE

UNITS	mm	NAME (INTENDED USE)	<b>FOXCONN</b> <sup>®</sup> FOXCONN INTERCONNECT TECHNOLOGY LIMITED.						
X. ± 1.5	X. °	DDR4 SO DIMM CONN.							
.X ± 1.0	.X °	PART NO. (INTENDED USE)	CLASS: <input type="checkbox"/> CONFIDENTIAL <input type="checkbox"/> SECRET <input checked="" type="checkbox"/> GENERAL						
.XX ± 0.2	.XX °	AS0A82*-H2RB-7H	TITLE: CUSTOMER DRAWING 260PIN SODDR4 5.2 REV.						
.XXX ±	.XXX °	APPD: C.S Li	DWG NO.: 317-0000-2253						
THESE DRAWINGS AND SPECIFICATIONS ARE THE PROPERTY OF FOXCONN INTERCONNECT TECHNOLOGY LIMITED. AND SHALL NOT BE REPRODUCED, COPIED OR USED IN ANY MANNER WITHOUT THE PRIOR WRITTEN CONSENT OF FOXCONN INTERCONNECT TECHNOLOGY LIMITED.		CHKD: Alex Wang	<table border="1"> <tr> <th>SCALE</th> <th>SHEET</th> <th>REV.</th> </tr> <tr> <td>N/A</td> <td>5/5</td> <td>D</td> </tr> </table>	SCALE	SHEET	REV.	N/A	5/5	D
SCALE	SHEET	REV.							
N/A	5/5	D							
		DRAW: Gary Xu 2014/9/24							