

Ten Output High Performance Clock Synchronizer, Jitter Cleaner, and Clock Distributor

FEATURES

- High Performance LVPECL, LVDS, LVC MOS PLL Clock Synchronizer
- Two Reference Clock Inputs (Primary and Secondary Clock) for Redundancy Support with Manual or Automatic Selection
- Accepts Two Differential Input (LVPECL or LVDS) References up to 500MHz (or Two LVC MOS Inputs up to 250MHz) as PLL Reference
- VCXO_IN Clock is Synchronized to One of Two Reference Clocks
- VCXO_IN Frequencies up to 1.5GHz (LVPECL) 800MHz for LVDS and 250MHz for LVC MOS Level Signaling
- Outputs Can be a Combination of LVPECL, LVDS, and LVC MOS (Up to 10 Differential LVPECL or LVDS Outputs or up to 20 LVC MOS Outputs), Output 9 can be Converted to an Auxiliary Input as a 2nd VC(X)O.
- Output Divider is Selectable to Divide by 1, 2, 3, 4, 5, 6, 8, 10, 12, 16, 18, 20, 24, 28, 30, 32, 36, 40, 42, 48, 50, 56, 60, 64, 70, or 80 On Each Output Individually up to Eight Dividers. (Except for Output 0 and 9, Output 0 Follows Output 1 Divider and Output 9 Follows Output 8 Divider)
- SPI Controllable Device Setting
- Individual Output Enable Control via SPI Interface
- Integrated On-Chip Non-Volatile Memory (EEPROM) to Store Settings without the Need to Apply High Voltage to the Device
- Optional Configuration Pins to Select Between Two Default Settings Stored in EEPROM
- Efficient Jitter Cleaning from Low PLL Loop Bandwidth
- Very Low Phase Noise PLL Core
- Programmable Phase Offset (Input Reference to Outputs)
- Wide Charge-Pump Current Range From 200 μ A to 3mA
- Dedicated Charge-Pump Supply for Wide Tuning Voltage Range VCOs
- Presets Charge-Pump to $V_{CC_CP}/2$ for Fast Center-Frequency Setting of VC(X)O, Controlled Via the SPI Bus
- SERDES Startup Mode (Depending on VCXO Range)
- Auxiliary Input: Output 9 can Serve as 2nd VCXO Input to Drive All Outputs or to Serve as PLL Feedback Signal
- \overline{RESET} or \overline{HOLD} Input Pin to Serve as Reset or Hold Functions
- REFERENCE SELECT for Manual Select Between Primary and Secondary Reference Clocks
- POWER DOWN (\overline{PD}) to Put Device in Standby Mode
- Analog and Digital PLL Lock Indicator
- Internally Generated VBB Bias Voltages for Single-Ended Input Signals
- Frequency Hold-Over Mode Activated by \overline{HOLD} Pin or SPI Bus to Improve Fail-Safe Operation
- Input to All Outputs Skew Control
- Individual Skew Control for Each Output with Each Output Divider
- Packaged in a QFN-64 Package
- ESD Protection Exceeds 2kV HBM
- Industrial Temperature Range of -40°C to 85°C

APPLICATIONS

- Low Jitter Clock Driver for High-End Telecom and Wireless Applications
- High Precision Test Equipment



These devices have limited built-in ESD protection. The leads should be shorted together or the device placed in conductive foam during storage or handling to prevent electrostatic damage to the MOS gates.



Please be aware that an important notice concerning availability, standard warranty, and use in critical applications of Texas Instruments semiconductor products and disclaimers thereto appears at the end of this data sheet.

DESCRIPTION

The CDCE72010 is a high-performance, low phase noise, and low skew clock synchronizer that synchronizes a VCXO (Voltage Controlled Crystal Oscillator) or VCO (Voltage Controlled Oscillator) frequency to one of two reference clocks. The clock path is fully programmable providing the user with a high degree of flexibility. The following relationship applies to the dividers:

$$\text{Frequency (VCXO_IN or AUX_IN)} / \text{Frequency (PRI_REF or SEC_REF)} = (R * M) / (P * N)$$

The VC(X)O_IN clock operates up to 1.5GHz through the selection of external VC(X)O and loop filter components. The PLL loop bandwidth and damping factor can be adjusted to meet different system requirements.

The CDCE72010 can lock to one of two reference clock inputs (PRI_REF and SEC_REF) and supports frequency hold-over mode for fail-safe and system redundancy. The outputs of the CDCE72010 are user definable and can be any combination of up to 10 LVPECL/LVDS outputs or up to 20 LVCMOS outputs. The built-in synchronization latches ensure that all outputs are synchronized for very low output skew.

All device settings, including output signaling, divider value selection, input selection, and many more, are programmable with the SPI (4-wire Serial Peripheral Interface). The SPI allows individual control of the device settings.

The device operates in a 3.3V environment and is characterized for operation from –40°C to +85°C.

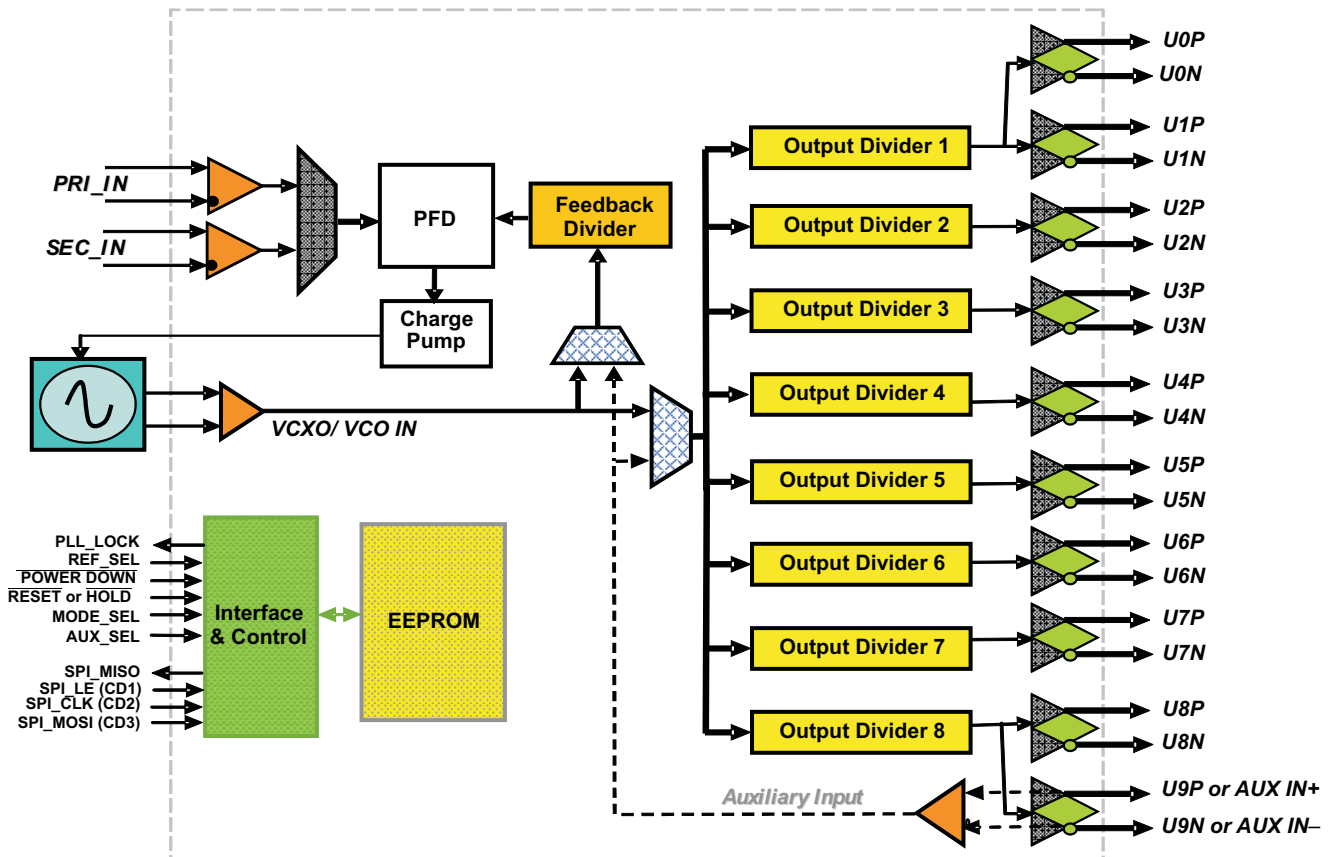

Figure 1. High Level Block Diagram of the CDCE72010

TERMINAL FUNCTIONS (continued)

TERMINAL		I/O	DESCRIPTION
NAME	NO.		
AUX_SEL	18	I	<i>This pin is used in CD mode only. If set to "1" or left unconnected, it disables output 9 and enables the AUXILIARY input to drive all outputs from output0 to output8 depending on the EEPROM configuration. If driven low in CD mode, it enables output 9 and makes all outputs driven by the VCXO Input depending on the internal EEPROM configuration.</i>
REF_SEL	47	I	If Auto Reference Select mode is OFF, this pin acts as an External Input Reference Select Pin; The REF_SEL signal selects one of two input clocks: REF_SEL [1]: PRI_REF is selected; REF_SEL [0]: SEC_REF is selected; The input has an internal 150-kΩ pull-up resistor and if left unconnected it will default to logic level "1". If Auto Reference Select mode in ON, this pin not used.
POWER_DOWN	17	I	This pin is active low and can be activated externally or by the corresponding bit in the SPI register (in case of logic high, the SPI setting is valid). This pin switches the device into powerdown mode The input has an internal 150-kΩ pull-up resistor and if left unconnected it will default to logic level "1".
RESET or HOLD	33	I	This LVC MOS input can be programmed (SPI) to act as HOLD or RESET. RESET is the default function. This pin is active low and can be activated external or via the corresponding bit in the SPI register. In the case of RESET, the CP (Charge Pump) is switched to 3-state and all counters are reset to zero. The LVPECL outputs are static low (N) and high (P) respectively, and the LVC MOS outputs are all low or high if inverted. In the case of HOLD, the CP (Charge Pump) is switched into 3-state mode only. After HOLD is released and with the next valid reference clock cycle, the charge pump is switched back into normal operation (CP stays in 3-state as long as no reference clock is valid). During HOLD, all outputs are at normal operation. This mode allows external control of "frequency hold-over" mode. The input has an internal 150-kΩ pull-up resistor.
VCXO IN+	53	I	VCXO input (+) for LVPECL+, LVDS+, and LVC MOS level inputs.
VCXO IN-	52	I	Complementary VCXO input for LVPECL-, LVDS- inputs. In the case of a LVC MOS level input on VCXO IN+, ground this pin.
PRI REF+	59	I	Universal input buffer (LVPECL, LVDS, LVC MOS) positive input for the Primary Reference Clock.
PRI REF-	58	I	Universal input buffer (LVPECL, LVDS) negative input for the Primary Reference Clock. In the case of LVC MOS signaling, ground this pin.
SEC REF+	62	I	Universal input buffer (LVPECL, LVDS, LVC MOS) positive input for the Secondary Reference Clock.
SEC REF-	61	I	Universal input buffer (LVPECL, LVDS,) negative input for the Secondary Reference Clock. In the case of LVC MOS signaling, ground this pin.
TESTOUTA	1	A	Analog Test Point for TI internal testing. Connect a 1kΩ pull-down resistor or leave unconnected.
STATUS	55	AO/O	LVC MOS output for TI internal testing. Leave unconnected unless it is configured as the IREF_CP pin. In this case it should be connected to a 12-kΩ resistor to GND.
CP_OUT	3	AO	Charge pump output
VBB	56	AO	Internal voltage bias analog output
PLL_LOCK	50	AI/O	LVC MOS output for PLL_LOCK information. This pin is set high if the PLL is in lock. This output can be programmed to be a digital lock detect or analog lock detect (see description of Analog Lock). The PLL is locked (set high), if the rising edge of either the PRI_REF or SEC_REF clock and the VCXO_IN clock at the PFD (Phase Frequency Detector) are inside the lock detect window for a predefined number of successive clock cycles. The PLL is out-of-lock (set low), if the rising edge of either the PRI_REF or SEC_REF clock and the VCXO_IN clock at the PFD are outside the lock detect window. The lock detect window and the number of successive clock cycles are user definable (via the SPI interface).

TERMINAL FUNCTIONS (continued)

TERMINAL		I/O	DESCRIPTION
NAME	NO.		
U0P:U0N U1P:U1N U2P:U2N U3P:U3N U4P:U4N U5P:U5N U6P:U6N U7P:U7N U8P:U8N	7,6 10,9 13,12 21,20 24,23 27,26 30,29 36,35 39,38	O	The main outputs of the CDCE72010 are user definable and can be any combination of up to 9 LVPECL outputs, 9 LVDS outputs, or up to 18 LVCMOS outputs. The outputs are selectable via the SPI interface. The power-up setting is EEPROM configurable.
U9P or AUXINP	42	I/O	Positive universal output buffer 9 can be 3-stated and used as a positive universal auxiliary input buffer (It requires external termination). The auxiliary input signal can be routed to drive the outputs or the feedback loop to the PLL.
U9N or AUXINN	41	I/O	Negative universal output buffer 9 can be 3-stated and used as a negative universal auxiliary input buffer (It requires external termination). The auxiliary input signal can be routed to drive the outputs or the feedback loop to the PLL.

PACKAGE THERMAL RESISTANCE FOR QFN (RGZ) PACKAGE ⁽¹⁾⁽²⁾

AIRFLOW (LFM)		θ_{JP} (°C/W) ⁽³⁾	θ_{JA} (°C/W)
0	JEDEC compliant board (6x6 VIAs on PAD)	1.5	28
100	JEDEC compliant board (6x6 VIAs on PAD)	1.5	17.6
0	Recommended layout (10x10 VIAs on PAD)	1.5	22.8
100	Recommended layout (10x10 VIAs on PAD)	1.5	13.8

(1) The package thermal impedance is calculated in accordance with JESD 51 and JEDEC2S2P (high-k board).

(2) Connected to GND with 9 thermal vias (0.3 mm diameter).

(3) θ_{JP} (Junction – Pad) is used for the QFN package, because the main heat flow is from the junction to the GND-pad of the QFN.

ABSOLUTE MAXIMUM RATINGS

over operating free-air temperature range (unless otherwise noted)

		MIN	MAX	UNIT
V_{CC} , AV_{CC} , V_{CC_CP}	Supply voltage range ⁽¹⁾	-0.5	4.6	V
V_I	Input voltage range ⁽²⁾	-0.5	$V_{CC} + 0.5$	V
V_O	Output voltage range ⁽²⁾	-0.5	$V_{CC} + 0.5$	V
	Input current	$V_I < 0, V_I > V_{CC}$		±20 mA
	Output current for LVPECL/LVCMOS Outputs	$0 < V_O < V_{CC}$		±50 mA
T_J	Junction temperature		125	°C
T_{stg}	Storage temperature range	-65	150	°C

(1) All supply voltages have to be supplied simultaneously.

(2) The input and output negative voltage ratings may be exceeded if the input and output clamp-current ratings are observed.

RECOMMENDED OPERATING CONDITIONS

for the CDCE72010 device for under the specified industrial temperature range of –40°C to 85°C

		MIN	NOM	MAX	UNIT
Power Supply					
V_{CC}	Supply voltage	3	3.3	3.6	V
V_{CC_PLL} , V_{CC_IN} , V_{CC_VCXO} , V_{CCA}	Analog supply voltage	3	3.3	3.6	
V_{CC_CP}		2.3		V_{CC}	V
P_{LVPECL}	REF at 30.72MHz VCXO at 491.52MHz Outputs are LVPECL-HS	Divider 1 set to divide by 8 (DCR 30%) Divider 2 set to divide by 4 (DCR 30%) Divider 3 set to divide by 2 (DCR 30%) Divider 4 set to divide by 2 (DCR 30%) Divider 5 set to divide by 1 (DCR 30%)		2.9	W
P_{LVDS}	REF at 30.72MHz VCXO at 491.52MHz Outputs are LVDS-HS	Divider 6 set to divide by 1 (DCR 0%) Divider 7 set to divide by 1 (DCR 0%) Divider 8 set to divide by 1 (DCR 0%) DCR: Divider Current Reduction Setting		2.0	W
P_{LVCMOS}	REF at 30.72MHz VCXO at 122.88MHz Outputs are LVCMOS	Divider 6 set to divide by 1 (DCR 0%) Divider 7 set to divide by 1 (DCR 0%) Divider 8 set to divide by 1 (DCR 0%) DCR: Divider Current Reduction Setting		2.2	W
P_{OFF}	REF at 30.72MHz VCXO at 491.52MHz	Dividers are disabled. Outputs are disabled.		775	mW
P_{PD}		Device is powered down		30	mW
Typical Operating Conditions at $V_{CC}=3.3V$ and 25°C unless otherwise specified.					
Differential Input Mode (PRI_REF, SEC_REF, VCXO_IN and AUX_IN)					
V_{INPP}	Input amplitude ⁽¹⁾	$(V_{INP} - V_{INN})$	0.1	1.3	V
V_{ICM}	Common-mode input voltage		1.0	$V_{CC} - 0.3$	V
I_{IH}	Differential input current high (No internal termination)	$V_I = V_{CC}, V_{CC} = 3.6 V$		20	μA
I_{IL}	Differential input current low(No internal termination)	$V_I = 0 V, V_{CC} = 3.6 V$	-20	20	μA
	Input capacitance on PRI_REF, SEC_REF and VCXO_REF			3	pF
	Input capacitance on AUX_IN			7	pF
LVCMOS Input Mode (SPI_CLK, SPI_MOSI, SPI_LE, PD, RESET, REF_SEL, MOD_SEL)					
V_{IL}	Low-level input voltage LVCMOS ⁽²⁾		0	$0.3 V_{CC}$	V
V_{IH}	High-level input voltage LVCMOS ⁽²⁾		$0.7 V_{CC}$	V_{CC}	V
V_{IK}	LVCMOS input clamp voltage	$V_{CC} = 3 V, I_I = -18 mA$		-1.2	V
I_{IH}	LVCMOS input current	$V_I = V_{CC}, V_{CC} = 3.6 V$		20	μA
I_{IL}	LVCMOS input	$V_I = 0 V, V_{CC} = 3.6 V$	-10	-40	μA
C_I	Input capacitance (LVCMOS signals)	$V_I = 0 V$ or V_{CC}		3	pF

- (1) V_{INPP} minimum and maximum is required to maintain ac specifications; the actual device function tolerates at a minimum V_{INPP} of 150mV.
- (2) V_{IL} and V_{IH} are required to maintain ac specifications; the actual device function tolerates a smaller input level of 1V, if an AC coupling to $V_{CC}/2$ is provided.

TIMING REQUIREMENTS

 over recommended ranges of supply voltage, load, and operating free-air temperature ⁽¹⁾⁽²⁾⁽³⁾⁽⁴⁾

PARAMETER		MIN	TYP	MAX	UNIT
PRI_REF/SEC_REFIN					
f_{REF_Single}	For single-ended inputs (LVCMOS) on PRI_REF and SEC_REF			250	MHz
f_{REF_Diff}	For differential inputs (LVDS and LVPECL) on PRI_REF and SEC_REF (R divider set to DIV2)			500	MHz
Duty Cycle Single	Duty cycle of PRI_REF or SEC_REF at $V_{CC}/2$	40%		60%	
Duty Cycle Diff	Duty cycle of PRI_REF or SEC_REF at $V_{CC}/2$	40%		60%	
VCXO_IN, AUX_IN					
f_{REF_Single}	For single-ended inputs (LVCMOS)			250	MHz
f_{REF_Diff}	For differential inputs (LVDS and LVPECL)			1500	MHz
Duty Cycle Single	Duty cycle of PRI_REF or SEC_REF at $V_{CC}/2$	40%		60%	
Duty Cycle Diff	Duty cycle of PRI_REF or SEC_REF at $V_{CC}/2$	40%		60%	
SPI/Control (SPI Bus Timing)					
f_{CTRL_CLK}	CTRL_CLK frequency			20	MHz
t ₂	SPI_MOSI to SPI_CLK setup time	10			ns
t ₃	SPI_MOSI to SPI_CLK hold time	10			ns
t ₄	SPI_CLK high duration	25			ns
t ₅	SPI_CLK low duration	25			ns
t ₁	SPI_LE to SPI_CLK setup time	10			ns
t ₆	SPI_CLK to SPI_LE setup time	10			ns
t ₇	SPI_LE pulse width	20			ns
t ₈	SPI_MISO to SPI_CLK data valid (first valid bit after LE)	10			ns
PD, RESET, Hold, REF_SEL					
t _r /t _f	Rise and fall time of the PD, RESET, Hold, REF_SEL signal from 20% to 80% of V_{CC}			4	ns

- (1) From 250MHz to 500MHz is achieved by setting the divide by 2 in P'
- (2) If the feedback clock (derived from the VCXO input) is less than 2MHz, the device stays in normal operation mode but the frequency detection circuitry resets the STATUS_VCXO signal and PLL_LOCK signal to low. Both status signals are no longer relevant. This affects the HOLD-Over-Function as well as the PLL_LOCK signal is no longer valid.
- (3) Use a square wave for lower frequencies (< 80 MHz).
- (4) Slew rate requirement

AC/DC CHARACTERISTICS

over the specified industrial temperature range of -40°C to 85°C

PARAMETER		TEST CONDITIONS		MIN	TYP ⁽¹⁾	MAX	UNIT
SPI Output (MISO) / PLL Digital (Output Mode)							
I_{OH}	High-level output current	$V_{CC} = 3.3\text{ V}$	$V_O = 1.65\text{ V}$		-30		mA
I_{OL}	Low-level output current	$V_{CC} = 3.3\text{ V}$	$V_O = 1.65\text{ V}$		33		mA
V_{OH}	High-level output voltage for LVCMOS outputs	$V_{CC} = 3\text{ V}$	$I_{OH} = -100\ \mu\text{A}$	$V_{CC}-0.5$			V
V_{OL}	Low-level output voltage for LVCMOS outputs	$V_{CC} = 3\text{ V}$	$I_{OL} = 100\ \mu\text{A}$			0.3	V
C_O	Output capacitance on MISO	$V_{CC} = 3.3\text{ V}; V_O = 0\text{ V}$ or V_{CC}			3		pF
I_{OZH}	3-state output current	$V_O = V_{CC}$			5		μA
I_{OZL}	3-state output current	$V_O = 0\text{ V}$			-5		μA
PLL Analog (Input Mode)							
$I_{OZH\text{ LOCK}}$	High-impedance state output current for PLL LOCK output ⁽²⁾	$V_O = 3.3\text{ V}$ ($\overline{\text{PD}}$ is set low)			22		μA
$I_{OZL\text{ LOCK}}$	High-impedance state output current for PLL LOCK output	$V_O = 0\text{ V}$ ($\overline{\text{PD}}$ is set low)			-22		μA
V_{T+}	Positive input threshold voltage	$V_{CC} = \text{min to max}$			$V_{CC} \times 0.55$		V
V_{T-}	Negative input threshold voltage	$V_{CC} = \text{min to max}$			$V_{CC} \times 0.35$		V
VBB							
VBB	VCXO termination voltage depends on the settings of the VCXO/AUX_IN input buffers	IBB = -0.2 mA Depending on the setting		0.9		1.9	V
Input Buffers Internal Termination Resistors (VCXO_IN, PRI_REF and SEC_REF)							
	Termination resistance ⁽³⁾	Single ended			53		Ω
Phase Detector							
$f_{CP\text{ max}}$	Maximum charge pump frequency	Default PFD pulse width delay				100	MHz
Charge Pump							
ICP3St	Charge pump 3-state current	$0.5\text{ V} < V_{CP} < V_{CC_CP} - 0.5\text{ V}$			15		nA
ICPA	ICP absolute accuracy	$V_{CP} = 0.5 V_{CC_CP}$; internal reference resistor			20		%
ICPA	ICP absolute accuracy	$V_{CP} = 0.5 V_{CC_CP}$; external reference resistor 12k Ω (1%)			5		%
ICPM	Sink/source current matching	$0.5\text{ V} < V_{CP} < V_{CC_CP} - 0.5\text{ V}$, SPI default settings			4		%
IVCPM	ICP vs VCP matching	$0.5\text{ V} < V_{CP} < V_{CC_CP} - 0.5\text{ V}$			6		%
$V_{I_REF_CP}$	Voltage on STATUS PIN when configured as I_REF_CP	12-k Ω resistor to GND (External current path for accurate charge pump current)			1.24		V

(1) All typical values are at $V_{CC} = 3.3\text{ V}$, $T_A = 25^{\circ}\text{C}$.

(2) 160-k Ω pull-down resistor

(3) Termination resistor can vary by 20%.

AC/DC CHARACTERISTICS (CONTINUED)

 over the specified industrial temperature range of -40°C to 85°C

PARAMETER		TEST CONDITIONS		MIN	TYP ⁽¹⁾	MAX	UNIT	
LVC MOS Output								
f_{clk}	Output frequency (see Figure 2)	Load = 5 pF to GND				250	MHz	
V_{OH}	High-level output voltage for LVC MOS outputs	$V_{\text{CC}} = \text{min to max}$	$I_{\text{OH}} = -100 \mu\text{A}$	$V_{\text{CC}} - 0.5$			V	
V_{OL}	Low-level output voltage for LVC MOS outputs	$V_{\text{CC}} = \text{min to max}$	$I_{\text{OL}} = 100 \mu\text{A}$			0.3	V	
I_{OH}	High-level output current	$V_{\text{CC}} = 3.3 \text{ V}$	$V_{\text{O}} = 1.65 \text{ V}$			-30	mA	
I_{OL}	Low-level output current	$V_{\text{CC}} = 3.3 \text{ V}$,	$V_{\text{O}} = 1.65 \text{ V}$			33	mA	
t_{pho}	Phase offset without using available delay adjustment	VCXO at 491.52MHz, Output 1 is divide by 16 and reference at 30.72MHz, M and N delays are fixed to one value (set to 0).				13	ns	
$t_{\text{pd(LH)}/t_{\text{pd(HL)}}$	Propagation delay from VCXO_IN to Outputs	Crosspoint to $V_{\text{CC}}/2$, load = 5 pF, (PLL bypass mode)				3.3	ns	
$t_{\text{sk(o)}}$	Skew, output-to-output LVC MOS single-ended output	Divide by 1 for all dividers				75	ps	
		Divide by 16 for all dividers				75		
		Divide by 1 for divider 1 divide by 16 for all other dividers				1400		
C_{O}	Output capacitance on Y0 to Y8	$V_{\text{CC}} = 3.3 \text{ V}; V_{\text{O}} = 0 \text{ V}$ or V_{CC}				5	pF	
C_{O}	Output capacitance on Y9	$V_{\text{CC}} = 3.3 \text{ V}; V_{\text{O}} = 0 \text{ V}$ or V_{CC}				5	pF	
I_{OZH}	3-state LVC MOS output current	$V_{\text{O}} = V_{\text{CC}}$				5	μA	
I_{OZL}	3-state LVC MOS output current	$V_{\text{O}} = 0\text{V}$				-5	μA	
I_{OPDH}	Power-down output current	$V_{\text{O}} = V_{\text{CC}}$				25	μA	
I_{OPDL}	Power-down output current	$V_{\text{O}} = 0\text{V}$				5	μA	
Duty cycle	LVC MOS	50% to 50%				45	55	%
$t_{\text{slew-rate}}$	Output rise/fall slew rate					3.6	5.2	V/ns

 (1) All typical values are at $V_{\text{CC}} = 3.3 \text{ V}$, $T_{\text{A}} = 25^{\circ}\text{C}$.

AC/DC CHARACTERISTICS (CONTINUED)over the specified industrial temperature range of -40°C to 85°C

PARAMETER		TEST CONDITIONS	MIN	TYP ⁽¹⁾	MAX	UNIT
LVDS Output						
f_{clk}	Output frequency	Open loop config. load, See Figure 2	0		800	MHz
$ V_{\text{OD}} $	Differential output voltage	$R_L = 100\ \Omega$	160		270	mV
ΔV_{OD}	LVDS VOD magnitude change				50	mV
V_{OS}	Offset voltage	-40°C to 85°C		1.24		V
ΔV_{OS}	V_{OS} magnitude change			40		mV
	Short circuit $V_{\text{OUT+}}$ to ground	$V_{\text{OUT}} = 0$			27	mA
	Short circuit $V_{\text{OUT-}}$ to ground	$V_{\text{OUT}} = 0$			27	mA
t_{pho} (2)	Reference to output phase offset without using available delay adjustment	VCXO at 491.52MHz, Output 1 is divide by 16 and reference at 30.72MHz, M and N delays are fixed to one value (set to 0), PFD: 240kHz, (M and N = 128)		14		ns
$t_{\text{pd(LH)}}$ / $t_{\text{pd(HL)}}$	Propagation delay time, VCXO_IN to output	Crosspoint to crosspoint, load, see Figure 2		3.0		ns
tsk(o) (3)	Skew, output to output LVDS output	Divide by 1 for all dividers		45		ps
		Divide by 16 for all dividers		50		
		Divide by 1 for divider 1 Divide by 16 for all other dividers		2800		
C_{O}	Output capacitance on Y0 to Y8	$V_{\text{CC}} = 3.3\ \text{V}$; $V_{\text{O}} = 0\ \text{V}$ or V_{CC}		5		pF
C_{O}	Output capacitance on Y9	$V_{\text{CC}} = 3.3\ \text{V}$; $V_{\text{O}} = 0\ \text{V}$ or V_{CC} 5		7		pF
I_{OPDH}	Power-down output current	$V_{\text{O}} = V_{\text{CC}}$			25	μA
I_{OPDL}	Power-down output current	$V_{\text{O}} = 0\ \text{V}$			5	μA
	Duty cycle		45		55	%
t_r/t_f	Rise and fall time	20% to 80% of V_{outpp}	110	140	160	ps
LVC MOS-TO-LVDS⁽⁴⁾						
tsk_{P_C}	Output skew between LVC MOS and LVDS outputs	Crosspoint to $V_{\text{CC}}/2$	0.9	1.4	1.9	ns

(1) All typical values are at $V_{\text{CC}} = 3.3\ \text{V}$, $T_A = 25^{\circ}\text{C}$.

(2) This is valid only for same REF_IN clock and Y output clock frequency. It can be adjusted by the SPI controller (reference delay M and VCXO delay N).

(3) The tsk(o) specification is only valid for equal loading of all outputs.

(4) Operating the LVC MOS or LVDS outputs above the maximum frequency will not cause a malfunction to the device, but the output signal swing may no longer meet the output specification. The phase of LVC MOS is lagging in reference to the phase of LVDS.

AC/DC CHARACTERISTICS (CONTINUED)

 over the specified industrial temperature range of -40°C to 85°C

PARAMETER		TEST CONDITIONS	MIN	TYP ⁽¹⁾	MAX	UNIT
LVDS Hi Swing Output						
f_{clk}	Output frequency	Open loop config. load, see Figure 3	0		800	MHz
$ V_{\text{OD}} $	Differential output voltage	$R_L = 100\ \Omega$	270		550	mV
ΔV_{OD}	LVDS VOD magnitude change				50	mV
V_{OS}	Offset voltage	-40°C to 85°C		1.24		V
ΔV_{OS}	V_{OS} magnitude change			40		mV
	Short Circuit $V_{\text{OUT+}}$ to ground	$V_{\text{OUT}} = 0$			27	mA
	Short Circuit $V_{\text{OUT-}}$ to ground	$V_{\text{OUT}} = 0$			27	mA
t_{pho} (2)	Reference to output phase offset without using available delay adjustment	VCXO at 491.52MHz, Output 1 is divide by 16 and reference at 30.72MHz. M and N delays are fixed to one value. (Set to 0) PFD: 240kHz, (M and N = 128)		14		ns
$t_{\text{pd(LH)}}$ / $t_{\text{pd(HL)}}$	Propagation delay time, VCXO_IN to output	Crosspoint to crosspoint, load Figure 3		3.0		ns
$t_{\text{sk(o)}}$ (3)	LVDS output skew	Divide by 1 for all dividers		45		ps
		Divide by 16 for all dividers		50		
		Divide by 1 for divider 1 Divide by 16 for all other dividers		2800		
C_{O}	Output capacitance on Y0 to Y8	$V_{\text{CC}} = 3.3\ \text{V}$; $V_{\text{O}} = 0\ \text{V}$ or V_{CC}		5		pF
C_{O}	Output capacitance on Y9	$V_{\text{CC}} = 3.3\ \text{V}$; $V_{\text{O}} = 0\ \text{V}$ or V_{CC}		7		pF
IOPDH	Power-down output current	$V_{\text{O}} = V_{\text{CC}}$			25	μA
IOPDL	Power-down output current	$V_{\text{O}} = 0\ \text{V}$			5	μA
Duty cycle			45		55	%
t_r/t_f	Rise and fall time	20% to 80% of V_{outpp}	110	160	190	ps
LVCMOS-TO-LVDS⁽⁴⁾						
$t_{\text{skP_C}}$	Output skew between LVCMOS and LVDS outputs	Crosspoint to $V_{\text{CC}}/2$	0.9	1.4	1.9	ns

(1) All typical values are at $V_{\text{CC}} = 3.3\ \text{V}$, $T_A = 25^{\circ}\text{C}$.

(2) This is valid only for same REF_IN clock and Y output clock frequency. It can be adjusted by the SPI controller (reference delay M and VCXO delay N).

(3) The $t_{\text{sk(o)}}$ specification is only valid for equal loading of all outputs.

(4) Operating the LVCMOS or LVPECL outputs above the maximum frequency will not cause a malfunction to the device, but the output signal swing may no longer meet the output specification. The phase of LVCMOS is lagging in reference to the phase of LVDS.

AC/DC CHARACTERISTICS (CONTINUED)

over the specified industrial temperature range of –40°C to 85°C

PARAMETER		TEST CONDITIONS	MIN	TYP ⁽¹⁾	MAX	UNIT
LVPECL Output						
f_{clk}	Output frequency	Open loop config.	0		1500	MHz
V_{OH}	LVPECL high-level output voltage	Load, see Figure 5	$V_{\text{CC}} - 1.06$		$V_{\text{CC}} - 0.88$	V
V_{OL}	LVPECL low-level output voltage	Load, see Figure 5	$V_{\text{CC}} - 2.02$		$V_{\text{CC}} - 1.58$	V
$ V_{\text{OD}} $	Differential output voltage	Load, see Figure 5	610		970	mV
$t_{\text{pho}}^{(2)}$	Reference to output phase offset without using available delay adjustment	VCXO at 491.52MHz, Output 1 is divide by 16 and reference at 30.72MHz, M and N delays are fixed to one value (set to 0), PFD: 240kHz, (M and N = 128)		14		ns
$t_{\text{pd(LH)}}$ / $t_{\text{pd(HL)}}$	Propagation delay time, VCXO_IN to output	Crosspoint to crosspoint, load, see Figure 5		3.4		ns
$t_{\text{sk(o)}}^{(3)}$	LVPECL output skew	Divide by 1 for all dividers		45		ps
		Divide by 16 for all dividers		50		
		Divide by 1 for divider 1 Divide by 16 for all other dividers		2700		
C_{O}	Output capacitance on Y0 to Y8	$V_{\text{CC}} = 3.3 \text{ V}$; $V_{\text{O}} = 0 \text{ V}$ or V_{CC}		5		pF
C_{O}	Output capacitance on Y9	$V_{\text{CC}} = 3.3 \text{ V}$; $V_{\text{O}} = 0 \text{ V}$ or V_{CC}		7		pF
IOPDH	Power-down output current	$V_{\text{O}} = V_{\text{CC}}$			25	μA
IOPDL	Power-down output current	$V_{\text{O}} = 0 \text{ V}$			5	μA
	Duty cycle		45		55	%
$t_{\text{r}}/t_{\text{f}}$	Rise and fall time	20% to 80% of V_{outpp}	55	75	135	ps
LVDS-TO-LVPECL						
tsk_{P_C}	Output skew between LVDS and LVPECL outputs	Crosspoint to $V_{\text{CC}}/2$;	0.9	1.1	1.3	ns
LVC MOS-TO-LVPECL						
tsk_{P_C}	Output skew between LVC MOS and LVPECL outputs ⁽⁴⁾	Crosspoint to $V_{\text{CC}}/2$;	–150	260	700	ps

(1) All typical values are at $V_{\text{CC}} = 3.3 \text{ V}$, $T_{\text{A}} = 25^{\circ}\text{C}$.

(2) This is valid only for same REF_IN clock and Y output clock frequency. It can be adjusted by the SPI controller (reference delay M and VCXO delay N).

(3) The tsk(o) specification is only valid for equal loading of all outputs. :

(4) Operating the LVC MOS or LVPECL outputs above the maximum frequency will not cause a malfunction to the device, but the output signal swing might no longer meet the output specification. The phase of LVC MOS is lagging in reference to the phase of LVDS.

AC/DC CHARACTERISTICS (CONTINUED)

over the specified industrial temperature range of –40°C to 85°C

PARAMETER		TEST CONDITIONS	MIN	TYP ⁽¹⁾	MAX	UNIT
LVPECL Hi Swing Output						
f_{clk}	Output frequency	Open loop config.	0		1500	MHz
V_{OH}	LVPECL high-level output voltage	Load, see Figure 5	$V_{CC} - 1.11$		$V_{CC} - 0.87$	V
V_{OL}	LVPECL low-level output voltage	Load, see Figure 5	$V_{CC} - 2.06$		$V_{CC} - 1.73$	V
$ VOD $	Differential output voltage	Load, see Figure 5	760		1160	mV
$t_{pho}^{(2)}$	Reference to output phase offset without using available delay adjustment	VCXO at 491.52MHz, Output 1 is divide by 16 and reference at 30.72MHz, M and N delays are fixed to one value (set to 0), PFD: 240kHz, (M and N = 128)		14		ns
$t_{pd(LH)}/t_{pd(HL)}$	Propagation delay time, VCXO_IN to output	Crosspoint to crosspoint, load, see Figure 5		3.4		ns
$t_{sk(o)}^{(3)}$	LVPECL output skew	Divide by 1 for all dividers		45		ps
		Divide by 16 for all dividers		50		
		Divide by 1 for divider 1 Divide by 16 for all other dividers		2700		
C_O	Output capacitance on Y0 to Y8	$V_{CC} = 3.3\text{ V}; V_O = 0\text{ V or }V_{CC}$		5		pF
C_O	Output capacitance on Y9	$V_{CC} = 3.3\text{ V}; V_O = 0\text{ V or }V_{CC}$		7		pF
IOPDH	Power-down output current	$V_O = V_{CC}$			25	μA
IOPDL	Power-down output current	$V_O = 0\text{ V}$			5	μA
	Duty cycle		45		55	%
t_r/t_f	Rise and fall time	20% to 80% of V_{outpp}	55	75	135	ps
LVDS-TO-LVPECL						
tsk_{P_C}	Output skew between LVDS and LVPECL outputs	Crosspoint to $V_{CC}/2$	0.9	1.1	1.3	ns
LVC MOS-TO-LVPECL						
tsk_{P_C}	Output skew between LVC MOS and LVPECL outputs ⁽⁴⁾	Crosspoint to $V_{CC}/2$	–150	260	700	ps

(1) All typical values are at $V_{CC} = 3.3\text{ V}$, $T_A = 25^\circ\text{C}$.

(2) This is valid only for same REF_IN clock and Y output clock frequency. It can be adjusted by the SPI controller (reference delay M and VCXO delay N).

(3) The $tsk(o)$ specification is only valid for equal loading of all outputs.

(4) Operating the LVC MOS or LVPECL output above the maximum frequency will not cause a malfunction to the device, but the output signal swing might no longer meet the output specification. The phase of LVC MOS is lagging in reference to the phase of LVDS and LVPECL.

PARAMETER MEASUREMENT INFORMATION

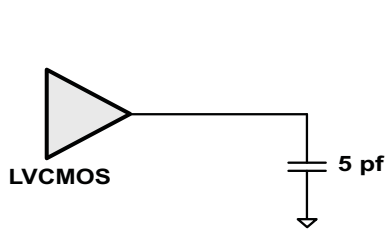

Figure 2. LVC MOS Output Termination Setup

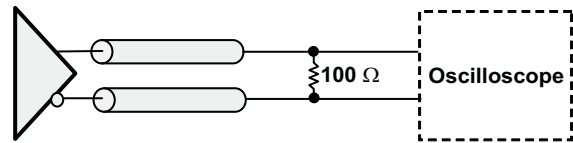

Figure 3. LVDS DC Termination Setup

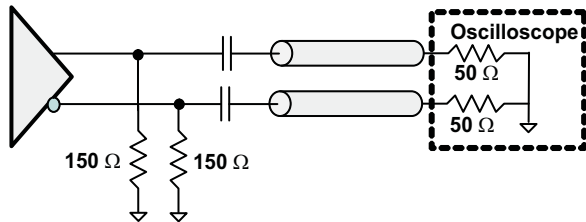

Figure 4. LVPECL AC Termination Setup

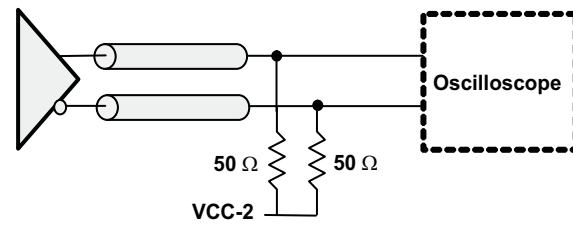

Figure 5. LVPECL DC Termination Setup

TYPICAL CHARACTERISTICS

LVPECL OUTPUT SWING
vs
FREQUENCY

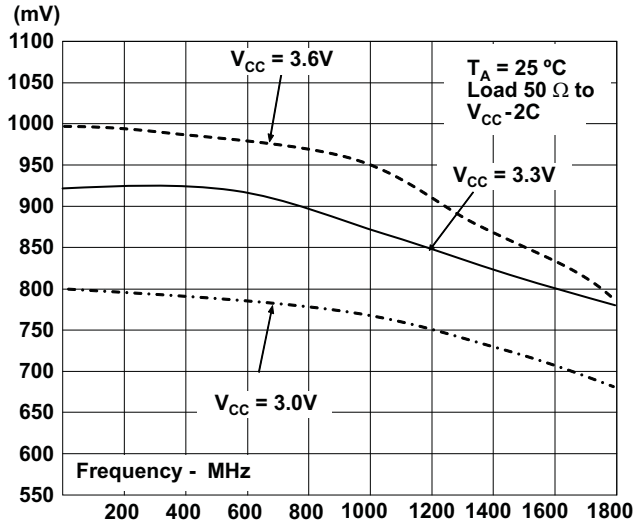

Figure 6.

Hi Swing LVPECL OUTPUT SWING
vs
FREQUENCY

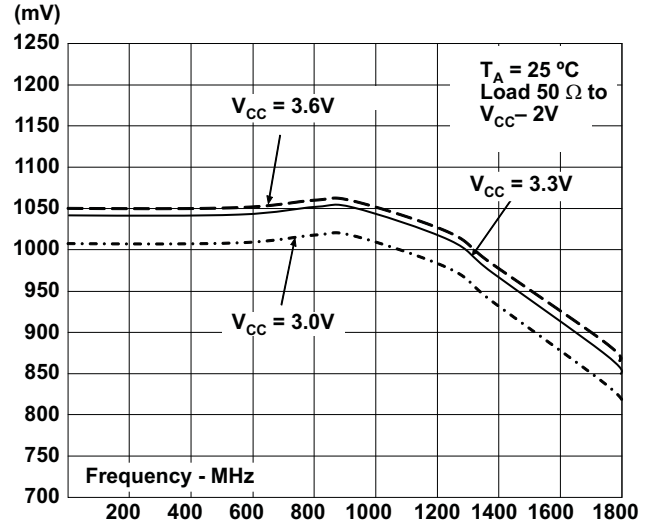

Figure 7.

LVDS OUTPUT SWING
vs
FREQUENCY

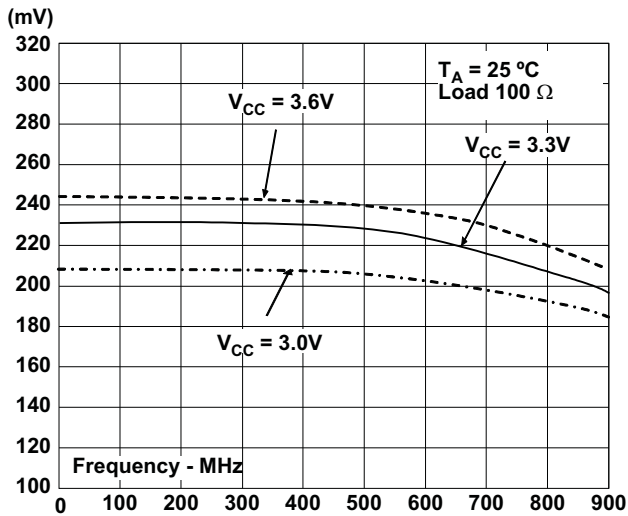

Figure 8.

Hi Swing LVDS OUTPUT SWING
vs
FREQUENCY

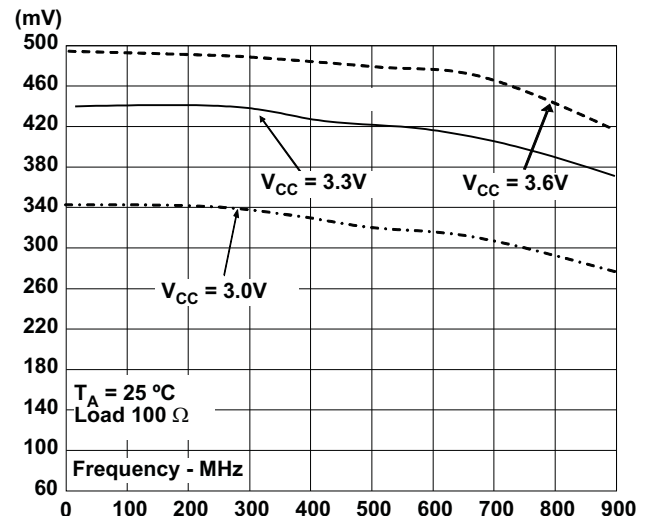

Figure 9.

TYPICAL CHARACTERISTICS (continued)

LVC MOS OUTPUT WING vs FREQUENCY

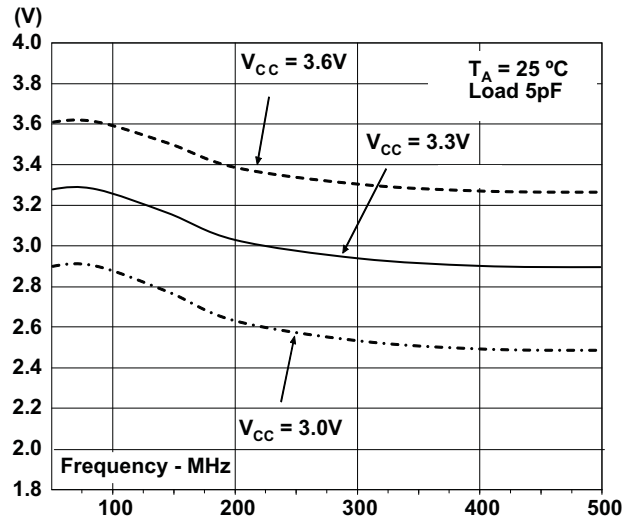

Figure 10.

APPLICATION INFORMATION

PHASE NOISE ANALYSIS

Phase noise is measured in a closed loop mode of 491.52MHz VCXO and 30.72MHz reference and a 100Hz loop. Output 1 is measured for divide by one, output 6 for divide by 4, and output 9 for divide by 16.

Table 1. Phase Noise for LVPECL High Swing

Phase Noise Specifications under following configuration: VCXO = 491.52MHz, REF = 30.72MHz, Divide by = 491.52MHz, Divide by 4 = 122.88MHz, Divide by 16 = 30.72MHz, PFD Frequency = 240KHz, Charge Pump Current = 2mA, Loop BW = 100Hz, Output 1 = 491.52 MHz, Output Buffer: LVPECL-HS						
PHASE NOISE AT OFFSET	VCXO OPEN LOOP	REFERENCE 30.72MHz	LVPECL-HS DIVIDE BY 1	LVPECL-HS DIVIDE BY 4	LVPECL-HS DIVIDE BY 16	UNIT
10Hz	-64	-107	-80	-92	-105	dBc/Hz
100Hz	-99	-123	-92	-104	-116	dBc/Hz
1kHz	-113	-134	-115	-127	-139	dBc/Hz
10kHz	-135	-153	-135	-145	-158	dBc/Hz
100kHz	-148	-156	-146	-155	-162	dBc/Hz
1MHz	-148	-158	-146	-155	-162	dBc/Hz
10MHz	-149		-147	-156		dBc/Hz

Table 2. Phase Noise for LVDS High Swing

Phase Noise Specifications under following configuration: VCXO = 491.52MHz, REF = 30.72MHz, Divide by = 491.52MHz, Divide by 4 = 122.88MHz, Divide by 16 = 30.72MHz, PFD Frequency = 240KHz, Charge Pump Current = 2mA Loop BW = 100Hz, Output 1 = 491.52 MHz, Output Buffer: LVDS-HS						
PARAMETER	VCXO OPEN LOOP	REFERENCE	LVDS-HS DIVIDE BY 1	LVDS-HS DIVIDE BY 4	LVDS-HS DIVIDE BY 16	UNIT
10Hz	-64	-107	-82	-94	-104	dBc/Hz
100Hz	-99	-123	-92	-105	-117	dBc/Hz
1kHz	-113	-134	-114	-127	-139	dBc/Hz
10kHz	-135	-153	-135	-145	-151	dBc/Hz
100kHz	-148	-156	-145	-152	-153	dBc/Hz
1MHz	-148	-158	-146	-152	-153	dBc/Hz
10MHz	-149		-146	-152		dBc/Hz

Table 3. Phase Noise for LVCMOS

Phase Noise Specifications under following configuration: VCXO = 491.52MHz, REF = 30.72MHz, Divide by = 491.52MHz, Divide by 4 = 122.88MHz, Divide by 16 = 30.72MHz, PFD Frequency = 240KHz, Charge Pump Current = 2mA, Loop BW = 100Hz, Output 1 = 491.52 MHz, Output Buffer: LVCMOS						
PARAMETER	VCXO OPEN LOOP	REFERENCE	N/A	LVCMOS DIVIDE BY 4	LVCMOS DIVIDE BY 16	UNIT
10Hz	-64	-107		-91	-105	dBc/Hz
100Hz	-99	-123		-104	-116	dBc/Hz
1kHz	-113	-134		-127	-139	dBc/Hz
10kHz	-135	-153		-140	-151	dBc/Hz
100kHz	-148	-156		-151	-159	dBc/Hz
1MHz	-148	-158		-153	-160	dBc/Hz
10MHz	-149			-154		dBc/Hz

SPI CONTROL INTERFACE

The serial interface of the CDCE72010 is a simple bidirectional SPI interface for writing and reading to and from the registers of the device. It consists of four control lines: SPI_CLK, SPI_MOSI, SPI_MISO, and SPI_LE. There are twelve 28-bit wide registers that can be saved to the EEPROM on-chip, and one status register that is a read only register. Those registers can be addressed by the four LSBs of a transferred word (bit 0, 1, 2, and bit 3). Every transmitted word must have 32 bits, starting with LSB first. Each word can be written separately. The transfer is initiated with the falling edge of SPI_LE; as long as SPI_LE is high, no data can be transferred. During SPI_LE low, data can be written. The data has to be applied at SPI_MOSI and has to be stable before the rising edge of SPI_CLK. The transmission is finished by a rising edge of SPI_LE.

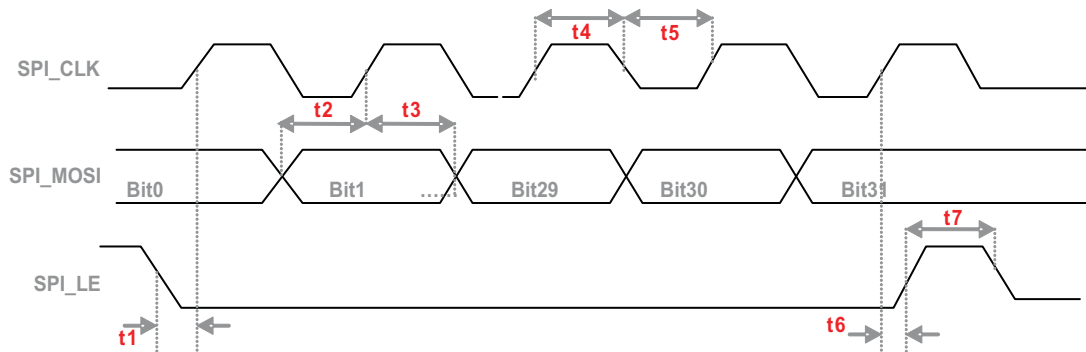

Figure 11. Timing Diagram for SPI Write Command

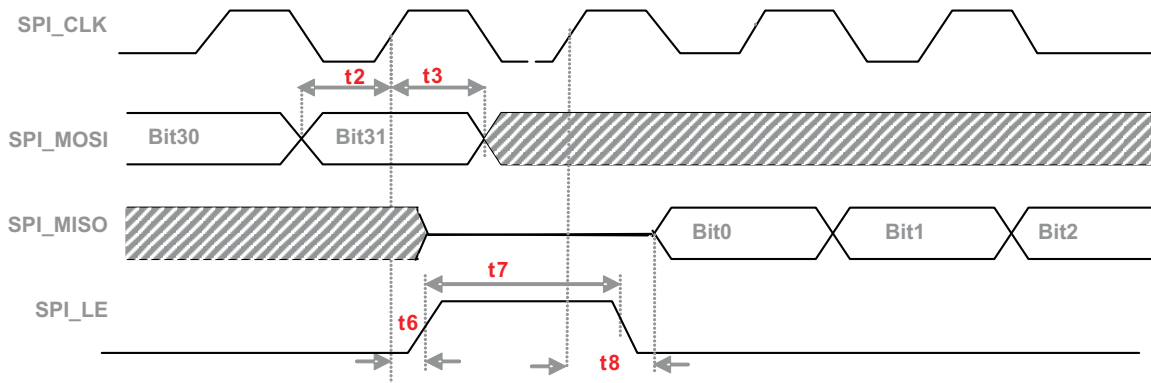

Figure 12. Timing Diagram for SPI Read Command

Table 4. Register Map

REGISTER	COMMENTS		WRITE PAYLOAD (DATA)	ADDRESS
WRITE COMMAND ON MOSI			31,30,29,28.....	4,3,2,1,0
Register0	Configuration	RAM/EEPROM	XXXX XXXX XXXX XXXX XXXX XXXX XXXX	0000
Register1	Configuration	RAM/EEPROM	XXXX XXXX XXXX XXXX XXXX XXXX XXXX	0001
Register2	Configuration	RAM/EEPROM	XXXX XXXX XXXX XXXX XXXX XXXX XXXX	0010
Register3	Configuration	RAM/EEPROM	XXXX XXXX XXXX XXXX XXXX XXXX XXXX	0011
Register4	Configuration	RAM/EEPROM	XXXX XXXX XXXX XXXX XXXX XXXX XXXX	0100
Register5	Configuration	RAM/EEPROM	XXXX XXXX XXXX XXXX XXXX XXXX XXXX	0101
Register6	Configuration	RAM/EEPROM	XXXX XXXX XXXX XXXX XXXX XXXX XXXX	0110
Register7	Configuration	RAM/EEPROM	XXXX XXXX XXXX XXXX XXXX XXXX XXXX	0111
Register8	Configuration	RAM/EEPROM	XXXX XXXX XXXX XXXX XXXX XXXX XXXX	1000
Register9	Configuration	RAM/EEPROM	XXXX XXXX XXXX XXXX XXXX XXXX XXXX	1001
Register10	Configuration	RAM/EEPROM	XXXX XXXX XXXX XXXX XXXX XXXX XXXX	1010
Register11	Configuration	RAM/EEPROM	XXXX XXXX XXXX XXXX XXXX XXXX XXXX	1011
Register12	Status/Control	RAM Only	XXXX XXXX XXXX XXXX XXXX XXXX XXXX	1100
Register13	Reserved		XXXX XXXX XXXX XXXX XXXX XXXX XXXX	1101
Instruction	Read command (address on 4 LSBs of payload)		XXXX XXXX XXXX XXXX XXXX XXXX AAAA	1110
Instruction	Write configuration to EEPROM - UNLOCKED		XXXX XXXX XXXX XXXX XXXX XXXX 0001	1111
Instruction	Write configuration to EEPROM – LOCKED		XXXX XXXX XXXX XXXX 1010 XXXX 0011	1111
READ COMMAND ON MISO			DATA PAYLOAD IN READ COMMAND	
	Payload after issuing a read command on MOSI		DDDD DDDD DDDD DDDD DDDD DDDD DDDD	XXXX

The SPI serial protocol accepts Word Write operation only. The 12 words include the register settings of the programmable functions of the device that can be modified to the customer application by changing one or more bits.

At powerup or if the Power Down (\overline{PD}) control signal is applied, the EEPROM loads its content into the registers. When issuing an EEPROM programming (LOCKED or UNLOCKED) instruction, a wait period of 50ms has to be inserted before another instruction is written to the device or power is removed.

CDCE72010 Default Configuration

The CDCE72010 on-board EEPROM has been factory preset to the default settings listed in [Table 5](#)

Table 5. CDCE72010 Default Configuration Settings

REGISTER	DEFAULT SETTING	REGISTER	DEFAULT SETTING
REG0000	002C0040	REG0007	EB040717
REG0001	83840051	REG0008	010C0158
REG0002	83400002	REG0009	01000049
REG0003	83400003	REG0010	0BFC07CA
REG0004	81800004	REG0011	C000058B
REG0005	81800005	REG0012	61E09B0C
REG0006	EB040006		

The default configuration programmed in the EEPROM is: a 10MHz primary reference single-ended, a 491.52MHz LVPECL VCXO running at 80kHz, and PFD with a 10Hz external loop filter. Reference Auto Select is off, M divider is set for 125, N divider is set to 768, charge pump current is set to 2.2mA, and feedback divider is set to divide by 8. Divider 1 is set to divide by 4, Dividers 2 and 3 are set to divide by 1, Dividers 4 and 5 are set to divide by 2, Dividers 6 and 7 are set to divide by 8, and Divider 8 is set to divide by 16. Output0:LVC MOS, Output1:Hi-LVPECL, Output2: Hi-LVPECL, Output3:Hi_LVPECL, Output4:LVPECL, Output5:LVPECL, Output6:Hi-LVDS, Output7:Hi-LVDS, Output8:LVC MOS and Output9:LVC MOS.

Register 0: SPI Mode

SPI Bit	RAM Bit	BIT NAME	RELATED BLOCK	DESCRIPTION/FUNCTION	POWER UP CONDITION										
0		A0		Address 0	0										
1		A1		Address 1	0										
2		A2		Address 2	0										
3		A3		Address 3	0										
4	0	INBUFSELX	Reference Input Buffers	Primary and secondary Buffer Type Select (LVPECL, LVDS or LVCMOS) XY(10) LVPECL, (11) LVDS, (00) LVCMOS- Input is Positive pin	EEPROM										
5	1	INBUFSELY													
6	2	PRISEL	Reference Input Buffer	When REFSELCTRL is set to 1, the following settings apply: If RAM Bits (2,3): 00 – No input buffer is selected/active If RAM Bits (2,3): 10 – PRI_BUF is selected, SEC_BUF is powered down If RAM Bits (2,3): 01 – SEC_BUF is selected, PRI_BUF is powered down If RAM Bits (2,3): 11 – Auto Select (PRI then SEC).	EEPROM										
7	3	SECSEL													
8	4	VCXOSEL	Divider START DETERM-Block	When set to 0, PRI- or SEC-clock is selected, depending on bits 2 and 3 (default) When set to 1, VCXO/AUX-clock is selected, overwrites bits 2 and 3	EEPROM										
9	5	REFSELCTRL	Reference Selection Control	Reference Select Control to select if the control of the reference is from the internal bit in Register 0 RAM bits 2 and 3 or from the external select pin. - When set to 0: the external pin REF_SEL takes over the selection between PRI and SEC. Autoselect is not available. - When set to 1: The external pin REF_SEL is ignored. The table in (Register 0 <2 and 3>) describes which reference input clock is selected and available (none, PRI, SEC or Autoselect). In autoselect mode, refer to the timing diagram.	EEPROM										
10	6	DELAY_PFD0	PFD	PFD pulse width PFD bit 0	EEPROM										
11	7	DELAY_PFD1		PFD pulse width PFD bit 1											
12	8	CP_MODE	Charge Pump	Selects 3V option [0] or 5V option [1]	EEPROM										
13	9	CP_DIR		Determines which direction CP current will regulate (Reference Clock leads to Feedback Clock, Positive CP output current [0], Negative CP output current [1])	EEPROM										
14	10	CP_SRC	Charge Pump Diagnostics	Switches the current source in the charge pump on when set to 1 (TI Test-GTME)	EEPROM										
15	11	CP_SNK		Switches the current sink in the charge pump on when set to 1 (TI Test-GTME)	EEPROM										
16	12	CP_OPA	Charge Pump	Switches the charge pump op-amp off when set to 1 (TI Test-GTME)	EEPROM										
17	13	CP_PRE		Preset charge pump output voltage to $V_{CC_CP}/2$, on [1], off [0]	EEPROM										
18	14	ICP0		CP current setting bit 0	EEPROM										
19	15	ICP1		CP current setting bit 1	EEPROM										
20	16	ICP2		CP current setting bit 2	EEPROM										
21	17	ICP3	CP current setting bit 3	EEPROM											
22	18	RESERVED			EEPROM										
23	19	RESERVED			EEPROM										
24	20	IREFRES	Charge Pump Diagnostics	Enables the 12-k Ω pull-down resistor at I_REF_CP pin when set to 1 (TI Test-GTME)	EEPROM										
25	21	PECL0HISWING	Output 0	High output voltage swing in LVPECL mode if set to 1	EEPROM										
26	22	CMOSMODE0PX	Output 0	LVCMOS mode select for OUTPUT 0 positive pin. (X,Y) = 00: Active, 10: Inverting, 11: Low, 01: 3-State	EEPROM										
27	23	CMOSMODE0PY													
28	24	CMOSMODE0NX	Output 0	LVCMOS mode select for OUTPUT 0 negative pin. (X,Y) = 00: Active, 10: Inverting, 11: Low, 01: 3-State	EEPROM										
29	25	CMOSMODE0NY													
30	26	OUTBUFSEL0X	Output 0	OUTPUT TYPE	RAM BITS										
				LVPECL	22	23	24	25	26	27	0	0	0	0	0
31	27	OUTBUFSELY	Output 0	LVDS	0	1	0	1	1	1					
				LVCMOS	See Settings Above ⁽¹⁾						0	0			
				All Outputs Disabled	0	1	0	1	1	0					

(1) Use description for bits 22, 23, 24, and 25 for setting the LVCMOS outputs.

Register 1: SPI Mode

SPI BIT	RAM BIT	BIT NAME	RELATED BLOCK	DESCRIPTION/FUNCTION	POWER UP CONDITION						
0		A0		Address 0	1						
1		A1		Address 1	0						
2		A2		Address 2	0						
3		A3		Address 3	0						
4	0	ACDCSEL	Input Buffers	If set to 0 AC Termination, If set to 1 DC termination	EEPROM						
5	1	HYSTEN	Input Buffers	If set to 1 Input Buffers Hysteresis enabled	EEPROM						
6	2	TERMSEL	Input Buffers	If set to 0 Input Buffer Internal Termination enabled	EEPROM						
7	3	PRIINVBB	Input Buffers	If set to 1 Primary Input Negative pin biased with internal VBB voltage	EEPROM						
8	4	SECINVBB	Input Buffers	If set to 1 Secondary Input Negative pin biased with internal VBB voltage	EEPROM						
9	5	FAILSAFE	Input Buffers	If set to 1 Fail Safe is enabled for all input buffers	EEPROM						
10	6	PH1ADJC0	Output 0 and 1	Coarse phase adjust select for Output Divider 1	EEPROM						
11	7	PH1ADJC1									
12	8	PH1ADJC2									
13	9	PH1ADJC3									
14	10	PH1ADJC4									
15	11	PH1ADJC5									
16	12	PH1ADJC6	Output 0 and 1	Output Divider 1 ratio select (see Table 7)	EEPROM						
17	13	OUT1DIVRSEL0									
18	14	OUT1DIVRSEL1									
19	15	OUT1DIVRSEL2									
20	16	OUT1DIVRSEL3									
21	17	OUT1DIVRSEL4									
22	18	OUT1DIVRSEL5	Output 0 and 1	When set to 0, the divider is disabled When set to 1, the divider is enabled	EEPROM						
23	19	OUT1DIVRSEL6									
24	20	EN01DIV	Output 0 and 1	When set to 0, the divider is disabled When set to 1, the divider is enabled	EEPROM						
25	21	PECL1HISWING	Output 1	High Output Voltage Swing in LVPECL Mode if set to 1	EEPROM						
26	22	CMOSMODE1PX	Output 1	LVCMOS mode select for OUTPUT 1 Positive Pin. (X,Y) = 00: Active, 10: Inverting, 11: Low, 01: 3-State	EEPROM						
27	23	CMOSMODE1PY									
28	24	CMOSMODE1NX	Output 1	LVCMOS mode select for OUTPUT 1 Negative Pin. (X,Y) = 00: Active, 10: Inverting, 11: Low, 01: 3-State	EEPROM						
29	25	CMOSMODE1NY									
30	26	OUTBUFSEL1X	Output 1	OUTPUT TYPE	RAM BITS						EEPROM
					22	23	24	25	26	27	
31	27	OUTBUFSEL1Y	Output 1	LVPECL	0	0	0	0	0	1	EEPROM
				LVDS	0	1	0	1	1	1	
				LVCMOS	See Settings Above ⁽¹⁾						
				All Outputs Disabled	0	1	0	1	1	0	

(1) Use description for bits 22, 23, 24, and 25 for setting the LVCMOS outputs.

Register 2: SPI Mode

SPI BIT	RAM BIT	BIT NAME	RELATED BLOCK	DESCRIPTION/FUNCTION	POWER UP CONDITION						
0		A0		Address 0	0						
1		A1		Address 1	1						
2		A2		Address 2	0						
3		A3		Address 3	0						
4	0	DLYM0	DELAY M	Reference phase delay M bit0	EEPROM						
5	1	DLYM1		Reference phase delay M bit1							
6	2	DLYM2		Reference phase delay M bit2							
7	3	DLYN0	DELAY N	Feedback phase delay N bit0	EEPROM						
8	4	DLYN1		Feedback phase delay N bit1							
9	5	DLYN2		Feedback phase delay N bit2							
10	6	PH2ADJC0	Output 2	Coarse phase adjust select for output divider 2	EEPROM						
11	7	PH2ADJC1									
12	8	PH2ADJC2									
13	9	PH2ADJC3									
14	10	PH2ADJC4									
15	11	PH2ADJC5									
16	12	PH2ADJC6									
17	13	OUT2DIVRSEL0	Output 2	Output Divider 2 ratio select (see Table 7)	EEPROM						
18	14	OUT2DIVRSEL1									
19	15	OUT2DIVRSEL2									
20	16	OUT2DIVRSEL3									
21	17	OUT2DIVRSEL4									
22	18	OUT2DIVRSEL5									
23	19	OUT2DIVRSEL6									
24	20	EN2DIV	Output 2	When set to 0, the divider is disabled When set to 1, the divider is enabled	EEPROM						
25	21	PECL2HISWING	Output 2	High Output Voltage Swing in LVPECL Mode if set to 1	EEPROM						
26	22	CMOSMODE2PX	Output 2	LVCMOS mode select for OUTPUT 2 Positive Pin. (X,Y) = 00: Active, 10: Inverting, 11: Low, 01: 3-State	EEPROM						
27	23	CMOSMODE2PY									
28	24	CMOSMODE2NX	Output 2	LVCMOS mode select for OUTPUT 2 Negative Pin. (X,Y) = 00: Active, 10: Inverting, 11: Low, 01: 3-State	EEPROM						
29	25	CMOSMODE2NY									
30	26	OUTBUFSEL2X	Output 2	OUTPUT TYPE	RAM BITS						
					22	23	24	25	26	27	
				LVPECL	0	0	0	0	0	1	EEPROM
				LVDS	0	1	0	1	1	1	
31	27	OUTBUFSEL2Y	Output 2	LVCMOS	See Settings Above ⁽¹⁾						
				All Outputs Disabled	0	1	0	1	1	0	

(1) Use description for bits 22, 23, 24, and 25 for setting the LVCMOS outputs.

Register 3: SPI Mode

SPI BIT	RAM BIT	BIT NAME	RELATED BLOCK	DESCRIPTION/FUNCTION	POWER UP CONDITION					
0		A0		Address 0	1					
1		A1		Address 1	1					
2		A2		Address 2	0					
3		A3		Address 3	0					
4	0	DIS_FDET_REF	PLL Freq. Detect	When set to 0, the REF-clock frequency detector is ON When set to 1, it is switched OFF	EEPROM					
5	1	DIS_FDET_FB	Diagnostics	When set to 1, the feedback path frequency detector is switched OFF (TI Test-GTME)	EEPROM					
6	2	BIAS_DIV01<0>	Output Divider 0 and 1	When BIAS_DIV01<1:0> = 00, No current reduction for all output-divider 01, Current reduction for all output-divider by about 20% 10, Current reduction for all output-divider by about 30%	EEPROM					
7	3	BIAS_DIV01<1>								
8	4	BIAS_DIV23<0>	Output Divider 2 and 3	When BIAS_DIV23<1:0> = 00, No current reduction for all output-divider 01, Current reduction for all output-divider by about 20% 10, Current reduction for all output-divider by about 30%	EEPROM					
9	5	BIAS_DIV23<1>								
10	6	PH3ADJC0	Output 3	Coarse phase adjust select for Output Divider 3	EEPROM					
11	7	PH3ADJC1								
12	8	PH3ADJC2								
13	9	PH3ADJC3								
14	10	PH3ADJC4								
15	11	PH3ADJC5								
16	12	PH3ADJC6								
17	13	OUT3DIVRSEL0	Output 3	Output Divider 3 ratio select (see Table 7)	EEPROM					
18	14	OUT3DIVRSEL1								
19	15	OUT3DIVRSEL2								
20	16	OUT3DIVRSEL3								
21	17	OUT3DIVRSEL4								
22	18	OUT3DIVRSEL5								
23	19	OUT3DIVRSEL6								
24	20	EN3DIV	Output 3	When set to 0, the divider is disabled When set to 1, the divider is enabled	EEPROM					
25	21	PECL3HISWING	Output 3	High Output Voltage Swing in LVPECL Mode if set to 1	EEPROM					
26	22	CMOSMODE3PX	Output 3	LVCMOS mode select for OUTPUT 3 Positive Pin. (X,Y) = 00: Active, 10: Inverting, 11: Low, 01: 3-State	EEPROM					
27	23	CMOSMODE3PY								
28	24	CMOSMODE3NX	Output 3	LVCMOS mode select for OUTPUT 3 Negative Pin. (X,Y) = 00: Active, 10: Inverting, 11: Low, 01: 3-State	EEPROM					
29	25	CMOSMODE3NY								
30	26	OUTBUFSEL3X	Output 3	OUTPUT TYPE	RAM BITS					
				LVPECL	0	0	0	0	0	1
31	27	OUTBUFSEL3Y	Output 3	LVDS	0	1	0	1	1	1
				LVCMOS	See Settings Above ⁽¹⁾			0	0	
				All Outputs Disabled	0	1	0	1	1	0

(1) Use description for bits 22, 23, 24, and 25 for setting the LVCMOS outputs

Register 4: SPI Mode

SPI BIT	RAM BIT	BIT NAME	RELATED BLOCK	DESCRIPTION/FUNCTION	POWER UP CONDITION					
0		A0		Address 0	0					
1		A1		Address 1	0					
2		A2		Address 2	1					
3		A3		Address 3	0					
4	0	RESERVED			EEPROM					
5	1	RESERVED			EEPROM					
6	2	RESERVED			EEPROM					
7	3	RESERVED			EEPROM					
8	4	HOLDONLOR	HOLD-Over	If set to 1 it will 3-state the charge pump to act as a HOLD on Loss of Reference Clocks (Primary and Secondary)	EEPROM					
9	5	RESERVED			EEPROM					
10	6	PH4ADJC0	Output 4	Coarse phase adjust select for Output Divider 4	EEPROM					
11	7	PH4ADJC1								
12	8	PH4ADJC2								
13	9	PH4ADJC3								
14	10	PH4ADJC4								
15	11	PH4ADJC5								
16	12	PH4ADJC6								
17	13	OUT4DIVRSEL0	Output 4	Output Divider 4 ratio select (see Table 7)	EEPROM					
18	14	OUT4DIVRSEL1								
19	15	OUT4DIVRSEL2								
20	16	OUT4DIVRSEL3								
21	17	OUT4DIVRSEL4								
22	18	OUT4DIVRSEL5								
23	19	OUT4DIVRSEL6								
24	20	EN4DIV	Output 4	When set to 0, the divider is disabled When set to 1, the divider is enabled	EEPROM					
25	21	PECL4HISWING	Output 4	High Output Voltage Swing in LVPECL Mode if set to 1	EEPROM					
26	22	CMOSMODE4PX	Output 4	LVCMOS mode select for OUTPUT 4 Positive Pin. (X,Y) = 00: Active, 10: Inverting, 11: Low, 01: 3-State	EEPROM					
27	23	CMOSMODE4PY								
28	24	CMOSMODE4NX	Output 4	LVCMOS mode select for OUTPUT 4 Negative Pin. (X,Y) = 00: Active, 10: Inverting, 11: Low, 01: 3-State	EEPROM					
29	25	CMOSMODE4NY								
30	26	OUTBUFSEL4X	Output 4	OUTPUT TYPE	RAM BITS					
					22	23	24	25	26	27
				LVPECL	0	0	0	0	0	1
31	27	OUTBUFSEL4Y	Output 4	LVDS	0	1	0	1	1	1
				LVC MOS	See Settings Above ⁽¹⁾					
				All Outputs Disabled	0	1	0	1	1	0

(1) Use description for bits 22, 23, 24, and 25 for setting the LVCMOS outputs

Register 5: SPI Mode

SPI BIT	RAM BIT	BIT NAME	RELATED BLOCK	DESCRIPTION/FUNCTION	POWER UP CONDITION						
0		A0		Address 0	1						
1		A1		Address 1	0						
2		A2		Address 2	1						
3		A3		Address 3	0						
4	0	BIAS_DIV45<0>	Output Divider 4 and 5	When BIAS_DIV45<1:0> = 00, No current reduction for all output-divider 01, Current reduction for all output-divider by about 20% 10, Current reduction for all output-divider by about 30%	EEPROM						
5	1	BIAS_DIV45<1>									
6	2	BIAS_DIV67<0>	Output Divider 6 and 7	When BIAS_DIV67<1:0> = 00, No current reduction for all output-divider 01, Current reduction for all output-divider by about 20% 10, Current reduction for all output-divider by about 30%	EEPROM						
7	3	BIAS_DIV67<1>									
8	4	RESERVED			EEPROM						
9	5	RESERVED			EEPROM						
10	6	PH5ADJC0	Output 5	Coarse phase adjust select for Output Divider 5	EEPROM						
11	7	PH5ADJC1									
12	8	PH5ADJC2									
13	9	PH5ADJC3									
14	10	PH5ADJC4									
15	11	PH5ADJC5									
16	12	PH5ADJC6									
17	13	OUT5DIVRSEL0	Output 5	Output Divider 5 ratio select (see Table 7)	EEPROM						
18	14	OUT5DIVRSEL1									
19	15	OUT5DIVRSEL2									
20	16	OUT5DIVRSEL3									
21	17	OUT5DIVRSEL4									
22	18	OUT5DIVRSEL5									
23	19	OUT5DIVRSEL6									
24	20	EN5DIV	Output 5	When set to 0, the divider is disabled When set to 1, the divider is enabled	EEPROM						
25	21	PECL5HISWING	Output 5	High Output Voltage Swing in LVPECL Mode if set to 1	EEPROM						
26	22	CMOSMODE5PX	Output 5	LVCMOS mode select for OUTPUT 5 Positive Pin. (X,Y) = 00: Active, 10: Inverting, 11: Low, 01: 3-State	EEPROM						
27	23	CMOSMODE5PY									
28	24	CMOSMODE5NX	Output 5	LVCMOS mode select for OUTPUT 5 Negative Pin. (X,Y) = 00: Active, 10: Inverting, 11: Low, 01: 3-State	EEPROM						
29	25	CMOSMODE5NY									
30	26	OUTBUFSEL5X	Output 5	OUTPUT TYPE	RAM BITS						
				LVPECL	22	23	24	25	26	27	EEPROM
31	27	OUTBUFSEL5Y	Output 5	LVDS	0	1	0	1	1	1	EEPROM
				LVCMOS	See Settings Above ⁽¹⁾						
				All Outputs Disabled	0	1	0	1	1	0	

(1) Use description for bits 22, 23, 24, and 25 for setting the LVCMOS outputs

Register 6: SPI Mode

SPI BIT	RAM BIT	BIT NAME	RELATED BLOCK	DESCRIPTION/FUNCTION	POWER UP CONDITION							
0		A0		Address 0	0							
1		A1		Address 1	1							
2		A2		Address 2	1							
3		A3		Address 3	0							
4	0	FB_FD_DESEL	LOCK-DET	0 Feedback Frequency Detector is connected to the Lock Detector 1 Feedback Frequency Detector is disconnected from the Lock Detector	EEPROM							
5	1	RESERVED		Set to 0								
6	2	FBDETERM_DIV_SEL	FB-Divider/Deterministic Blocks	0 FB-Deterministic Clock divided by 1 1 FB-Deterministic Clock divided by 2	EEPROM							
7	3	FBDETERM_DIV2_DIS		0 FB-Deterministic-DIV2-Block in normal operation 1 FB-Deterministic-DIV2 reset (here REG6_RB<2> == 0)								
8	4	FB_START_BYPASS		0 FB-Divider started with delay block (RC), normal operation 1 FB-Divider can be started with external REF_SEL-signal (pin)								
9	5	DET_START_BYPASS	All Output Dividers	0 Output-Dividers started with delay block (RC), normal operation 1 Output-Dividers can be started with external NRESET-signal (pin)	EEPROM							
10	6	PH6ADJC0	Output 6	Coarse phase adjust select for Output Divider 6	EEPROM							
11	7	PH6ADJC1										
12	8	PH6ADJC2										
13	9	PH6ADJC3										
14	10	PH6ADJC4										
15	11	PH6ADJC5										
16	12	PH6ADJC6										
17	13	OUT6DIVRSEL0	Output 6	Output Divider 6 ratio select (see Table 7)	EEPROM							
18	14	OUT6DIVRSEL1										
19	15	OUT6DIVRSEL2										
20	16	OUT6DIVRSEL3										
21	17	OUT6DIVRSEL4										
22	18	OUT6DIVRSEL5										
23	19	OUT6DIVRSEL6										
24	20	EN6DIV	Output 6	When set to 0, the divider is disabled When set to 1, the divider is enabled	EEPROM							
25	21	PECL6HISWING	Output 6	High Output Voltage Swing in LVPECL Mode if set to 1	EEPROM							
26	22	CMOSMODE6PX	Output 6	LVCMOS mode select for OUTPUT 6 Positive Pin. (X,Y) = 00: Active, 10: Inverting, 11: Low, 01: 3-State	EEPROM							
27	23	CMOSMODE6PY										
28	24	CMOSMODE6NX	Output 6	LVCMOS mode select for OUTPUT 6 Negative Pin. (X,Y) = 00: Active, 10: Inverting, 11: Low, 01: 3-State	EEPROM							
29	25	CMOSMODE6NY										
30	26	OUTBUFSEL6X	Output 6	OUTPUT TYPE	RAM BITS							
				LVPECL	22	23	24	25	26	27	0	0
31	27	OUTBUFSEL6Y	Output 6	LVDS	0	1	0	1	1	1	0	0
				LVCMOS	See Settings Above ⁽¹⁾						0	0
				All Outputs Disabled	0	1	0	1	1	0		

(1) Use description for bits 22,23,24, and 25 for setting the LVCMOS outputs

Register 7: SPI Mode

SPI BIT	RAM BIT	BIT NAME	RELATED BLOCK	DESCRIPTION/FUNCTION	POWER UP CONDITION					
0		A0		Address 0	1					
1		A1		Address 1	1					
2		A2		Address 2	1					
3		A3		Address 3	0					
4	0	LOCKW 0	LOCK-DET	Lock-detect window Bit 0 (Refer to Reg 9 RAM Bits 6 and 7)	EEPROM					
5	1	LOCKW 1		Lock-detect window Bit 1 (Refer to Reg 9 RAM Bits 6 and 7)	EEPROM					
6	2	RESERVED		Set to 0						
7	3	LOCKC0		Number of coherent lock events Bit 0						
8	4	LOCKC1		Number of coherent lock events Bit 1						
9	5	ADLOCK		Selects Digital PLL_LOCK 0, Selects Analog PLL_LOCK 1						
10	6	PH7ADJC0	Output 7	Coarse phase adjust select for Output Divider 7	EEPROM					
11	7	PH7ADJC1								
12	8	PH7ADJC2								
13	9	PH7ADJC3								
14	10	PH7ADJC4								
15	11	PH7ADJC5								
16	12	PH7ADJC6	Output 7	Output Divider 7 ratio select (see Table 7)	EEPROM					
17	13	OUT7DIVRSEL0								
18	14	OUT7DIVRSEL1								
19	15	OUT7DIVRSEL2								
20	16	OUT7DIVRSEL3								
21	17	OUT7DIVRSEL4								
22	18	OUT7DIVRSEL5	Output 7	When set to 0, the divider is disabled When set to 1, the divider is enabled	EEPROM					
23	19	OUT7DIVRSEL6								
24	20	EN7DIV	Output 7	High Output Voltage Swing in LVPECL Mode if set to 1	EEPROM					
25	21	PECL7HISWING	Output 7	LVC MOS mode select for OUTPUT 7 Positive Pin (X,Y) = 00: Active, 10: Inverting, 11: Low, 01: 3-State	EEPROM					
26	22	CMOSMODE7PX	Output 7	LVC MOS mode select for OUTPUT 7 Negative Pin. (X,Y) = 00: Active, 10: Inverting, 11: Low, 01: 3-State	EEPROM					
27	23	CMOSMODE7PY								
28	24	CMOSMODE7NX	Output 7	LVC MOS mode select for OUTPUT 7 Negative Pin. (X,Y) = 00: Active, 10: Inverting, 11: Low, 01: 3-State	EEPROM					
29	25	CMOSMODE7NY								
30	26	OUTBUFSEL7X	Output 7	OUTPUT TYPE	RAM BITS					
					22	23	24	25	26	27
31	27	OUTBUFSEL7Y	Output 7	LVPECL	0	0	0	0	0	1
				LVDS	0	1	0	1	1	1
				LVC MOS	See Settings Above ⁽¹⁾					
				All Outputs Disabled	0	1	0	1	1	0

(1) Use description for bits 22, 23, 24, and 25 for setting the LVC MOS outputs

Register 8: SPI Mode

SPI BIT	RAM BIT	BIT NAME	RELATED BLOCK	DESCRIPTION/FUNCTION	POWER UP CONDITION					
0		A0		Address 0	0					
1		A1		Address 1	0					
2		A2		Address 2	0					
3		A3		Address 3	1					
4	0	VCXOBUFSELX	VCXO and AUX Input Buffers	VCXO and AUX Input Buffer Type Select (LVPECL, LVDS or LVCMOS) XY(10) LVPECL, (11) LVDS, (00) LVCMOS- Input is Positive Pin	EEPROM					
5	1	VCXOBUFSELY								
6	2	VCXOACDCSEL				If Set to 0 AC Termination, If set to 1 DC Termination				
7	3	VCXOHYSTEN				If Set to 1 Input Buffers Hysteresis enabled				
8	4	VCXOTERMSEL		If Set to 0 Input Buffer Internal Termination enabled						
9	5	VCXOINVB	VCXO Input Buffer	If Set to 1 It Biases VCXO Input negative pin with internal VCXOVBB Voltage	EEPROM					
10	6	PH8ADJC0	Output 8 and 9	Coarse phase adjust select for Output Divider 8	EEPROM					
11	7	PH8ADJC1								
12	8	PH8ADJC2								
13	9	PH8ADJC3								
14	10	PH8ADJC4								
15	11	PH8ADJC5								
16	12	PH8ADJC6								
17	13	OUT8DIVRSEL0	Output 8 and 9	Output Divider 8 ratio select (see Table 7)	EEPROM					
18	14	OUT8DIVRSEL1								
19	15	OUT8DIVRSEL2								
20	16	OUT8DIVRSEL3								
21	17	OUT8DIVRSEL4								
22	18	OUT8DIVRSEL5								
23	19	OUT8DIVRSEL6								
24	20	EN89DIV	Output 8 and 9	When set to 0, the divider is disabled When set to 1, the divider is enabled	EEPROM					
25	21	PECL8HISWING	Output 8	High Output Voltage Swing in LVPECL Mode if set to 1	EEPROM					
26	22	CMOSMODE8PX	Output 8	LVCMOS mode select for OUTPUT 8 Positive Pin. (X,Y) = 00: Active, 10: Inverting, 11: Low, 01: 3-State	EEPROM					
27	23	CMOSMODE8PY								
28	24	CMOSMODE8NX	Output 8	LVCMOS mode select for OUTPUT 8 Negative Pin. (X,Y) = 00: Active, 10: Inverting, 11: Low, 01: 3-State	EEPROM					
29	25	CMOSMODE8NY								
30	26	OUTBUFSEL8X	Output 8	OUTPUT TYPE	RAM BITS					
					22	23	24	25	26	27
				LVPECL	0	0	0	0	0	1
31	27	OUTBUFSEL8Y	Output 8	LVDS	0	1	0	1	1	1
				LVCMOS	See Settings Above ⁽¹⁾					
				All Outputs Disabled	0	1	0	1	1	0

(1) Use description for bits 22, 23, 24, and 25 for setting the LVCMOS outputs

Register 9: SPI Mode

SPI BIT	RAM BIT	BIT NAME	RELATED BLOCK	DESCRIPTION/FUNCTION	POWER UP CONDITION					
0		A0		Address 0	1					
1		A1		Address 1	0					
2		A2		Address 2	0					
3		A3		Address 3	1					
4	0	HOLDF	HOLD-Over	Enables the Frequency Hold-Over (External Hold Over Function based on the external circuitry) on 1, off 0	EEPROM					
5	1	RESERVED								
6	2	HOLD		3-State Charge Pump 0 - (equal to HOLD pin function)						
7	3	HOLDTR		HOLD function always activated 1 (recommended for test purposes, only) Triggered by analog PLL Lock detect outputs If analog PLL Lock Signal is [1] (PLL locked), HOLD is activated If analog PLL Lock Signal is [0] (PLL not lock), HOLD is deactivated						
8	4	HOLD_CNT0		HOLD1 Function is reactivated after X Ref Clock Cycles. Defined by (HOLD_CNT0,HOLD_CNT1) : X = Number of Clock Cycles.						
9	5	HOLD_CNT1		For (00) : X = 64, (01) : X = 128, (10) : X = 256, (11) : X = 512 Clock Cycles						
10	6	LOCKW 2	LOCK-DET	Extended Lock-detect window Bit 2 (also refer to Reg 7 RAM Bits 0 and 1)	EEPROM					
11	7	LOCKW 3		Extended Lock-detect window Bit 3 (also refer to Reg 7 RAM Bits 0 and 1)						
12	8	NOINV_RESOL_INT	Chip CORE	When set to 0, SPI/HOLD_INT and SPI/RESET_INT inverted (default) When set to 1, SPI/HOLD_INT and SPI/RESET_INT not inverted	EEPROM					
13	9	DIVSYNC_DIS	<i>Diagnostic: PLL N/M Divider</i>	When GTME = 0, this Bit has no functionality, But when GTME = 1, then: When set to 0, START-Signal is synchronized to N/M Divider Input Clocks When set to 1, START-Sync N/M Divider in PLL are bypassed	EEPROM					
14	10	START_BYPASS	Divider START DETERM-Block	When set to 0, START-Signal is synchronized to VCXO-Clock When set to 1, START-Sync Block is bypassed	EEPROM					
15	11	INDET_BP	Divider START DETERM-Block	When set to 0, Sync Logic active when VCXO/AUX-Clocks are available When set to 1, Sync Logic is independent from VCXO- and/or AUX-Clocks	EEPROM					
16	12	PLL_LOCK_BP	Divider START DETERM-Block	When set to 0, Sync Logic waits for 1st PLL_LOCK state When set to 1, Sync Logic independent from 1st PLL_LOCK	EEPROM					
17	13	LOW_FD_FB_EN	Divider START DETERM-Block	When set to 0, Sync Logic is independent from VCXO/DIV_FB freq. (PLL-FD) When set to 1, Sync Logic is started for VCXO/DIV_FB > -600KHz, stopped for VCXO/DIV_FB < -600KHz	EEPROM					
18	14	NPRESET_MDIV	PLL M/FB-Divider	When set to 0, M-Divider uses NHOLD as NPRESET When set to 1, M-Divider NOT preseted by NHOLD	EEPROM					
19	15	BIAS_DIV_FB<0>	Feedback Divider	When BIAS_DIV_FB<1:0> = 00, No current reduction for FB-Divider 01, Current reduction for FB-Divider by about 20% 10, Current reduction for FB-Divider by about 30%	EEPROM					
20	16	BIAS_DIV_FB<1>								
21	17	BIAS_DIV89<0>	Output Divider 8 and 9	When BIAS_DIV89<1:0> = 00, No current reduction for all output-rivider 01, Current reduction for all output-divider by about 20% 10, Current reduction for all output-divider by about 30%	EEPROM					
22	18	BIAS_DIV89<1>								
23	19	AUXINVBB	AUX Input Buffer	If set to 1 it biases AUX Input Negative pin with internal VCXOVBB voltage.	EEPROM					
24	20	DIS_AUX_Y9		If set to 1 AUX in Input Mode Buffer Is disabled. If set to 0 it follows the behavior of FB_MUX_SEL and OUT_MUX_SEL bits settings.						
25	21	PECL9HISWING	Output 9	High output voltage swing in LVPECL Mode if set to 1	EEPROM					
26	22	CMOSMODE9PX	Output 9	LVCMOS mode select for OUTPUT 9 Positive pin. (X,Y) = 00: Active, 10: Inverting, 11: Low, 01: 3-State	EEPROM					
27	23	CMOSMODE9PY								
28	24	CMOSMODE9NX	Output 9	LVCMOS mode select for OUTPUT 9 Negative pin. (X,Y) = 00: Active, 10: Inverting, 11: Low, 01: 3-State	EEPROM					
29	25	CMOSMODE9NY								
30	26	OUTBUFSEL9X	Output 9	OUTPUT TYPE	RAM BITS					
				LVPECL	22	23	24	25	26	27
31	27	OUTBUFSEL9Y	Output 9	LVDS	0	1	0	1	1	1
				LVCMOS	See Settings Above ⁽¹⁾			0	0	
				All Outputs Disabled	0	1	0	1	1	0

(1) Use description for bits 22, 23, 24, and 25 for setting the LVCMOS outputs

Register 10: SPI Mode

SPI BIT	RAM BIT	BIT NAME	RELATED BLOCK	DESCRIPTION/FUNCTION	POWER UP CONDITION
0		A0		Address 0	0
1		A1		Address 1	1
2		A2		Address 2	0
3		A3		Address 3	1
4	0	M0	Reference (PRI/SEC) Divider M	Reference Divider M Bit 0	EEPROM
5	1	M1		Reference Divider M Bit 1	
6	2	M2		Reference Divider M Bit 2	
7	3	M3		Reference Divider M Bit 3	
8	4	M4		Reference Divider M Bit 4	
9	5	M5		Reference Divider M Bit 5	
10	6	M6		Reference Divider M Bit 6	
11	7	M7		Reference Divider M Bit 7	
12	8	M8		Reference Divider M Bit 8	
13	9	M9		Reference Divider M Bit 9	
14	10	M10		Reference Divider M Bit 10	
15	11	M11		Reference Divider M Bit 11	
16	12	M12		Reference Divider M Bit 12	
17	13	M13		Reference Divider M Bit 13	
18	14	N0	VCXO/AUX/SEC Divider N	VCXO Divider N Bit 0	EEPROM
19	15	N1		VCXO Divider N Bit 1	
20	16	N2		VCXO Divider N Bit 2	
21	17	N3		VCXO Divider N Bit 3	
22	18	N4		VCXO Divider N Bit 4	
23	19	N5		VCXO Divider N Bit 5	
24	20	N6		VCXO Divider N Bit 6	
25	21	N7		VCXO Divider N Bit 7	
26	22	N8		VCXO Divider N Bit 8	
27	23	N9		VCXO Divider N Bit 9	
28	24	N10		VCXO Divider N Bit 10	
29	25	N11		VCXO Divider N Bit 11	
30	26	N12		VCXO Divider N Bit 12	
31	27	N13		VCXO Divider N Bit 13	

Register 11: SPI Mode

SPI BIT	RAM BIT	BIT NAME	RELATED BLOCK	DESCRIPTION/FUNCTION	POWER UP CONDITION
0		A0		Address 0	1
1		A1		Address 1	1
2		A2		Address 2	0
3		A3		Address 3	1
4	0	PRI_DIV2	Input Buffers	If set to 1 enables Primary Reference Divide by 2	EEPROM
5	1	SEC_DIV2	Input Buffers	If set to 1 enables Secondary Reference Divide by 2	EEPROM
6	2	FB_DIS	FB Path Integer Counter 32	When set to 0, FB divider is active When set to 1, FB divider is disabled	EEPROM
7	3	FB_CML_SEL	FB Path Integer Counter 32	When set to 0, FB clock is CMOS type When set to 1, FB clock is CML type and uses CML2CMOS converter in PLL	EEPROM
8	4	FB_INCLK_INV	FB-Divider/ Deterministic Blocks	When set to 0, Input clock for FB not inverted (normal mode, low speed) When set to 1, Input clock for FB inverted (higher speed mode)	EEPROM
9	5	FB_COUNT32_0	FB Path Integer Counter 32	Feedback Counter Bit0	EEPROM
10	6	FB_COUNT32_1		Feedback Counter Bit1	
11	7	FB_COUNT32_2		Feedback Counter Bit2	
12	8	FB_COUNT32_3		Feedback Counter Bit3	
13	9	FB_COUNT32_4		Feedback Counter Bit4	
14	10	FB_COUNT32_5		Feedback Counter Bit5	
15	11	FB_COUNT32_6		Feedback Counter Bit6	
16	12	FB_PHASE0	FB Path Integer Counter 32	Feedback Phase Adjust Bit0	EEPROM
17	13	FB_PHASE1		Feedback Phase Adjust Bit1	
18	14	FB_PHASE2		Feedback Phase Adjust Bit2	
19	15	FB_PHASE3		Feedback Phase Adjust Bit3	
20	16	FB_PHASE4		Feedback Phase Adjust Bit4	
21	17	FB_PHASE5		Feedback Phase Adjust Bit5	
22	18	FB_PHASE6		Feedback Phase Adjust Bit6	
23	19	PD_PLL	PLL	If set to 0, PLL is in normal mode If set to 1, PLL is powered down	EEPROM
24	20	FB_MUX_SEL See Table 6	Clock Tree and Deterministic Block	When set to 0, the VCXO Clock is selected for the Clock Tree and FB-Div and Det When set to 1, the AUX Clock is selected for the Clock Tree and FB-Div and Det	EEPROM
25	21	OUT_MUX_SEL See Table 6	Clock Tree	If Set to 0 it selects the VCXO Clock and if Set to 1 it selects the AUX Clock	EEPROM
26	22	FB_SEL	Diagnostics	<i>Feed Back Path Selects FB/VCXO-Path when set to 0 (TI Test-GTME) The Secondary Reference clock input is selected when set to 1 (TI Test-GTME)</i>	EEPROM
27	23	NRESHAPE1	Reference Selection Control	Reshapes the Reference Clock Signal 0, Disable Reshape 1	EEPROM
28	24	SEL_DEL1		If set to 0 it enables short delay for fast operation If Set to 1 Long Delay recommended for Input References below 150Mhz	EEPROM
29	25	RESET_HOLD	Reset Circuitry	If set to 1 the RESET or HOLD pin acts as $\overline{\text{HOLD}}$, set to 0 it acts as $\overline{\text{RESET}}$	EEPROM
30	26	EPUNLOCK	Status	EEPROM Unlock	EEPROM
31	27	EPSTATUS	Status	EEPROM Status	EEPROM

Table 6. Output Buffers Source Feed, PLL Source Feed, and AUX IN/OUTPUT 9 Selection

FB_MUX_SEL	OUT_MUX_SEL	PLL FEED AND OUTPUTS FEED	AUX INPUT OR OUTPUT 9
0	0	VCXO::PLL, VCXO::Y0...Y9 and Deterministic Block	OUTPUT 9 is enabled
1	0	AUXIN::PLL, VCXO::Y0...Y8 and Deterministic Block	AUX IN is enabled
0	1	VCXO::PLL, AUXIN::Y0...Y8 and Deterministic Block	AUX IN is enabled
1	1	AUXIN::PLL, AUXIN::Y0...Y8 and Deterministic Block	AUX IN is enabled

Register 12: SPI Mode (RAM only Register)

SPI BIT	RAM BIT	BIT NAME	RELATED BLOCK	DESCRIPTION/FUNCTION	POR DEFAULT	
0		A0		Address 0		0
1		A1		Address 1		0
2		A2		Address 2		1
3		A3		Address 3		1
4	0	RESERVED				RAM
5	1	RESERVED				RAM
6	2	RESERVED				RAM
7	3	RESERVED				RAM
8	4	INDET_AUX	Status (Read Only)	It indicates that a clock is present at AUX-input (Y9) , when set to 1		RAM
9	5	INDET_VCXO	Status (Read Only)	It indicates that a clock is present at VCXO-input , when set to 1		RAM
10	6	PLL_LOCK	Status (Read Only)	It indicates that the PLL is locked when set to 1		RAM
11	7	\overline{PD}	Power Down	Power-down mode on when set to 0, Off when set to 1	1	RAM
12	8	\overline{RESET} or \overline{HOLD}	Reset	If set to 0 this bit forces " \overline{RESET} or \overline{HOLD} " depending on the setting of RESET_HOLD bit in Register 11. If set to 0 \overline{RESET} or \overline{HOLD} are asserted. Set for 1 for normal operation.	1	RAM
13	9	GTME	Diagnostics	General Test Mode Enable, Test Mode is only enabled, if this bit is set to 1 This bit controls many test modes on the device.	0	RAM
14	10	REVISION0	Status	Read only: Revision Control Bit 0		RAM
15	11	REVISION1	Status	Read only: Revision Control Bit 1		RAM
16	12	REVISION2	Status	Read only: Revision Control Bit 2		RAM
17	13	PD_IO	Diagnostics	When set to 0, all blocks are on. (TI Test-GTME) When set to 1, the VCXO Input, AUX Input and all output buffers and divider blocks are disabled. This test is done to measure the effect of the I/O circuitry on the Charge Pump. (TI Test-GTME)	0	RAM
18	14	SXOIREF	Diagnostics	If set to 0 that Status pin is used as CMOS output to enable TI test modes. Set to 1 when IREFRES is set to 1 and 12-K Ω resistor is connected. (TI Test-GTME)	0	RAM
19	15	SHOLD	Diagnostics	Routes the HOLD signal to the PLL_LOCK pin when set to 1 (TI Test-GTME)	0	RAM
20	16	RESERVED			0	RAM
21	17	STATUS0	Diagnostics	TI test registers. For TI use only Route internal signals to external STATUS pin. STATUS3, STATUS2, STATUS1, STATUS0 (S3, S2, S1, S0) will select that internal status signal that will be routed to the external STATUS pin.	1	RAM
22	18	STATUS1				
23	19	STATUS2				
24	20	STATUS3				
25	21	TITSTCFG0	Diagnostics	TI test registers. For TI use only	0	RAM
26	22	TITSTCFG1	Diagnostics	TI test registers. For TI use only	0	RAM
27	23	TITSTCFG2	Diagnostics	TI test registers. For TI use only	0	RAM
28	24	TITSTCFG3	Diagnostics	TI test registers. For TI use only	0	RAM
29	25	PRIACTIVITY	Status	It indicates activity on the Primary when set to - (read only bit)		RAM
30	26	SECACTIVITY	Status	It indicates activity on the Secondary when set to - (read only bit)		RAM
31	27	RESERVED				RAM

NOTE:

If TI test bits (Register 12< RAM bits 17,18,19, 20> are set to 1000, Reference Select from the Smart Mux will show on the STATUS pin (Low = Primary REF is selected and High = Secondary REF is selected).

OUTPUT DIVIDERS SETTINGS

The CDCE72010 has a complex multi stage output divider. The table below describes the setting of Bits 13:19 of Register 1 to 8 and the setting for the feedback divider bits 5:11 of register 11. The table below describes divider settings and the phase relation of the outputs with respect to divide by one clock. To calculate the phase relation between 2 different dividers see Output Divider and Phase Adjust Section in this document.

Table 7. Output Dividers and Feedback Divide Settings and Phase Output

FOR REGISTER 1 TO 8 RAM BITS {19[BIT6] TO 13[BIT0]} FOR REGISTER 11 RAM BITS {11[BIT6] TO 5[BIT0]}							DIVIDE BY TOTAL	PHASE LAG FROM DIVIDE BY 1	
[Bit 6]	[Bit 5]	[Bit 4]	[Bit 3]	[Bit 2]	[Bit 1]	[Bit 0]		Cycle	Degree
0	1	0	0	0	0	0	1	0	0
1	0	0	0	0	0	0	2	0.5	180
1	0	0	0	0	0	1	3	0	0
1	0	0	0	0	1	0	4	0.5	180
1	0	0	0	0	1	1	5	0	0
0	0	0	0	0	0	0	4'	14.5	5220
0	0	0	0	0	0	1	6	21	7560
0	0	0	0	0	1	0	8	28.5	10260
0	0	0	0	0	1	1	10	35	12600
0	0	0	0	1	0	0	8'	16.5	5940
0	0	0	0	1	0	1	12	24	8640
0	0	0	0	1	1	0	16	32.5	11700
0	0	0	0	1	1	1	20	40	14400
0	0	0	1	0	0	0	12'	18.5	6660
0	0	0	1	0	0	1	18	27	9720
0	0	0	1	0	1	0	24	36.5	13140
0	0	0	1	0	1	1	30	45	16200
0	0	0	1	1	0	0	16'	20.5	7380
0	0	0	1	1	0	1	24'	30	10800
0	0	0	1	1	1	0	32	40.5	14580
0	0	0	1	1	1	1	40	50	18000
0	0	1	0	0	0	0	20'	22.5	8100
0	0	1	0	0	0	1	30'	33	11880
0	0	1	0	0	1	0	40'	44.5	16020
0	0	1	0	0	1	1	50	55	19800
0	0	1	0	1	0	0	24'	24.5	8820
0	0	1	0	1	0	1	36	36	12960
0	0	1	0	1	1	0	48	48.5	17460
0	0	1	0	1	1	1	60	60	21600
0	0	1	1	0	0	0	28	26.5	9540
0	0	1	1	0	0	1	42	39	14040
0	0	1	1	0	1	0	56	52.5	18900
0	0	1	1	0	1	1	70	65	23400
0	0	1	1	1	0	0	32'	28.5	10260
0	0	1	1	1	0	1	48'	42	15120
0	0	1	1	1	1	0	64	56.5	20340
0	0	1	1	1	1	1	80	70	25200

CONFIGURATION DEFAULT MODE

The CDCE72010 has two modes of operation, SPI Interface and Configuration Default Mode. The Configuration Default mode is selected when MODE_SELECT Pin is driven low and it is used where SPI interface is not available. In the CD Mode configuration, the SPI interface Pins become static control pins CD1, CD2, CD3 and AUX_SEL as shown in the Pin description. The CD Mode signals are sampled only at power up or after Power Down are asserted.

In CD Mode BYPASS, CD1 and CD2 are used to switch between EEPROM saved configurations. -CD1 allows swapping Divider and Phase Adjust value between output couples.

- CD2 allows changing the output type for each output.
- AUX_SEL Controls the Output Mux between VCXO and AUX Input.
- CD3 must be grounded in CD Mode.

Without any interface a single device with a single program can have multiple configurations that can be implemented on more than one socket.

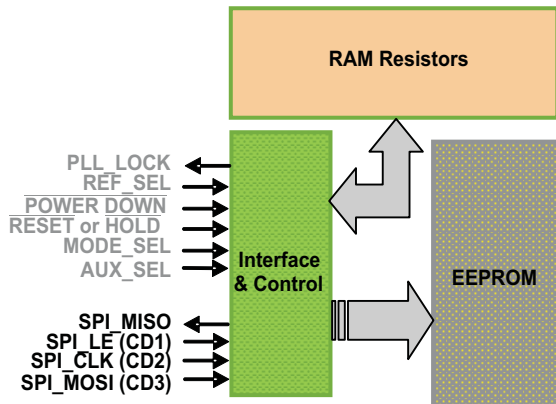

Figure 13. Writing to EEPROM via SPI Bus in Manufacturing, 3rd Party Vendor or at TI Test

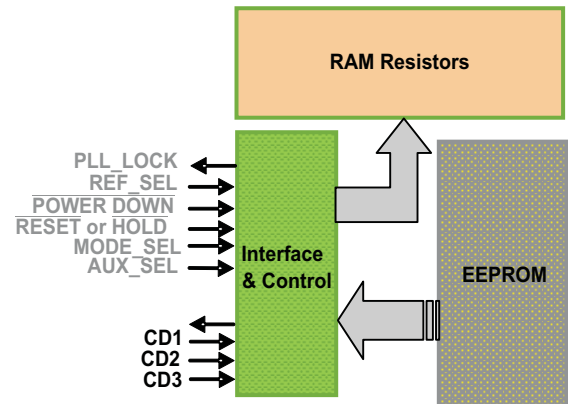

Figure 14. Using CD1, CD2 to Control What is Copied From EEPROM Into RAM Registers at Power Up

Register 0: CD Mode

SPI BIT	RAM BIT	BIT NAME	RELATED BLOCK	DESCRIPTION/FUNCTION	POWER UP CONDITION
0		A0		Address 0	0
1		A1		Address 1	0
2		A2		Address 2	0
3		A3		Address 3	0
4	0	INBUFSELX	Reference Input Buffers	Primary and Secondary Buffer Type Select (LVPECL, LVDS or LVCMOS) XY(10) LVPECL, (11) LVDS, (00) LVCMOS- Input is Positive Pin	EEPROM
5	1	INBUFSELY			
6	2	PRISEL	Reference Input Buffer	When REFSELCTRL is set to 1 the following settings apply: If RAM Bit (2,3): 00 – no Input Buffer is selected/active If RAM Bit (2,3): 10 – PRI_BUF is selected, SEC_BUF is powered down If RAM Bit (2,3): 01 – SEC_BUF is selected, PRI_BUF is powered down If RAM Bit (2,3): 11 – Auto Select (PRI then SEC).	EEPROM
7	3	SECSEL			
8	4	VCXOSEL	Divider START DETERM-Block	When set to 0, PRI- or SEC-Clocks are selected, depending on Bits 2 and 3 (default) When set to 1, VCXO/AUX-clock selected, overwrites Bits 2 and 3	EEPROM
9	5	REFSELCTRL	Reference Selection Control	Reference Select Control to select if the control of the reference is from the internal bit in Register 0 RAM bits 2 and 3 or from the external select pin. - When set to 0: The external pin REF_SEL takes over the selection between PRI and SEC. Autoselect is not available. - When set to 1: The external pin REF_SEL is ignored. The Table in (Register 0 <2 and 3>) describes, which reference input clock is selected and available at (none, PRI, SEC or Autoselect). In autoselect mode, refer to the timing diagram	EEPROM
10	6	DELAY_PFD0	PFD	PFD Pulse Width PFD Bit 0	EEPROM
11	7	DELAY_PFD1	PFD	PFD Pulse Width PFD Bit 1	EEPROM
12	8	CP_MODE	Charge Pump	Selects 3V option [0] or 5V option [1]	EEPROM
13	9	CP_DIR		Determines in which direction CP current will regulate (Reference Clock leads to Feedback Clock; Positive CP output current [0]; Negative CP output current [1])	EEPROM
14	10	CP_SRC	Diagnostics	Switches the current source in the Charge Pump on when set to 1 (TI Test-GTME)	EEPROM
15	11	CP_SNK		Switches the current sink in the Charge Pump on when set to 1 (TI Test-GTME)	EEPROM
16	12	CP_OPA		Switches the Charge Pump op-amp off when set to 1 (TI Test-GTME)	EEPROM
17	13	CP_PRE	Charge Pump	Preset Charge Pump output voltage to $V_{CC_CP}/2$, on [1], off [0]	EEPROM
18	14	ICP0		CP Current Setting Bit 0	EEPROM
19	15	ICP1		CP Current Setting Bit 1	EEPROM
20	16	ICP2		CP Current Setting Bit 2	EEPROM
21	17	ICP3		CP Current Setting Bit 3	EEPROM
22	18	RESERVED			EEPROM
23	19	RESERVED			EEPROM
24	20	IREFRES	Diagnostics	Enables the 12k pull-down resistor at I_REF_CP Pin when set to 1 (TI Test-GTME)	EEPROM
25	21	PECL0HISWING	Output 0	High output voltage swing in LVPECL Mode if set to 1	EEPROM
26	22	RESERVED			EEPROM
27	23	RESERVED			EEPROM
28	24	OUTBUF0CD2LX	CD2 Low	Output Buffer 0 Signaling Selection when CD2 In low (X,Y) = 01: LVPECL, 11: LVDS, 00: LVCMOS, 10: Output Disable	EEPROM
29	25	OUTBUF0CD2LY			
30	26	OUTBUF0CD2HX	CD2 High	Output Buffer 0 Signaling Selection when CD2 in high (X,Y) = 01: LVPECL, 11: LVDS, 00: LVCMOS, 10: output disable	EEPROM
31	27	OUTBUF0CD2HY			

Register 1: CD Mode

SPI BIT	RAM BIT	BIT NAME	RELATED BLOCK	DESCRIPTION/FUNCTION	POWER UP CONDITION
0		A0		Address 0	1
1		A1		Address 1	0
2		A2		Address 2	0
3		A3		Address 3	0
4	0	ACDCSEL	Input Buffers	If Set to 0 AC Termination, If set to 1 DC termination	EEPROM
5	1	HYSTEN	Input Buffers	If Set to 1 Input Buffers Hysteresis enabled	EEPROM
6	2	TERMSEL	Input Buffers	If Set to 0 Input Buffer Internal Termination enabled	EEPROM
7	3	PRIINVBB	Input Buffers	If Set to 1 Primary Input Negative Pin biased with internal VBB voltage.	EEPROM
8	4	SECINVBB	Input Buffers	If Set to 1 Secondary Input Negative Pin biased with internal VBB voltage	EEPROM
9	5	FAILSAFE	Input Buffers	If Set to 1 Fail Safe is enabled for all input buffers.	EEPROM
10	6	PH1ADJC0	Output 0 and 1	Coarse phase adjust select for output divider 1	EEPROM
11	7	PH1ADJC1			
12	8	PH1ADJC2			
13	9	PH1ADJC3			
14	10	PH1ADJC4			
15	11	PH1ADJC5			
16	12	PH1ADJC6			
17	13	OUT1DIVRSEL0	Output 0 and 1	OUTPUT DIVIDER 1 Ratio Select (See Table 7)	EEPROM
18	14	OUT1DIVRSEL1			
19	15	OUT1DIVRSEL2			
20	16	OUT1DIVRSEL3			
21	17	OUT1DIVRSEL4			
22	18	OUT1DIVRSEL5			
23	19	OUT1DIVRSEL6			
24	20	EN01DIV	Output 0 and 1	When set to 0, the divider is disabled When set to 1, the divider is enabled	EEPROM
25	21	PECL1HISWING	Output 1	High output voltage swing in LVPECL Mode if set to 1	EEPROM
26	22	DIVPHA1CD1H	CD1 High	CD1 PIN is high and DIVPHA1CD1H is set to low Loads Output Divider 1 and Phase Adjust 1 into OUTPUT 1 CD1 PIN is high and DIVPHA1CD1H is set to high Loads Output Divider 2 and Phase Adjust 2 into OUTPUT 1	EEPROM
27	23	DIVPHA1CD1L	CD1 Low	CD1 PIN is low and DIVPHA1CD1L is set to low Loads Output Divider 1 and Phase Adjust 1 into OUTPUT 1 CD1 PIN is low and DIVPHA1CD1L is set to high Loads Output Divider 2 and Phase Adjust 2 into OUTPUT 1	EEPROM
28	24	OUTBUF1CD2LX	CD2 Low	Output Buffer 1 Signaling Selection when CD2 in low (X,Y) = 01: LVPECL, 11: LVDS, 00: LVCMOS, 10: Output Disable	EEPROM
29	25	OUTBUF1CD2LY			
30	26	OUTBUF1CD2HX	CD2 High	Output Buffer 1 Signaling Selection when CD2 in high (X,Y) = 01: LVPECL, 11: LVDS, 00: LVCMOS, 10: Output Disable	EEPROM
31	27	OUTBUF1CD2HY			

Register 2: CD Mode

SPI BIT	RAM BIT	BIT NAME	RELATED BLOCK	DESCRIPTION/FUNCTION	POWER UP CONDITION
0		A0		Address 0	0
1		A1		Address 1	1
2		A2		Address 2	0
3		A3		Address 3	0
4	0	DLYM0	DELAY M	Reference Phase Delay M Bit0	EEPROM
5	1	DLYM1		Reference Phase Delay M Bit1	
6	2	DLYM2		Reference Phase Delay M Bit2	
7	3	DLYN0	DELAY N	Feedback Phase Delay N Bit0	EEPROM
8	4	DLYN1		Feedback Phase Delay N Bit1	
9	5	DLYN2		Feedback Phase Delay N Bit2	
10	6	PH2ADJC0	Output 2	Coarse phase adjust select for output divider 2	EEPROM
11	7	PH2ADJC1			
12	8	PH2ADJC2			
13	9	PH2ADJC3			
14	10	PH2ADJC4			
15	11	PH2ADJC5			
16	12	PH2ADJC6	Output 2	OUTPUT DIVIDER 2 Ratio Select (See Table 7)	EEPROM
17	13	OUT2DIVRSEL0			
18	14	OUT2DIVRSEL1			
19	15	OUT2DIVRSEL2			
20	16	OUT2DIVRSEL3			
21	17	OUT2DIVRSEL4			
22	18	OUT2DIVRSEL5	Output 2	When set to 0, the divider is disabled When set to 1, the divider is enabled	EEPROM
23	19	OUT2DIVRSEL6			
24	20	EN2DIV	Output 2	When set to 0, the divider is disabled When set to 1, the divider is enabled	EEPROM
25	21	PECL2HISWING	Output 2	High output voltage swing in LVPECL Mode if set to 1	EEPROM
26	22	DIVPHA2CD1H	CD1 High	CD1 PIN is high and DIVPHA2CD1H is set to low Loads Output Divider 2 and Phase Adjust 2 into OUTPUT 2 CD1 PIN is high and DIVPHA2CD1H is set to high Loads Output Divider 1 and Phase Adjust 1 into OUTPUT 2	EEPROM
27	23	DIVPHA2CD1L	CD1 Low	CD1 PIN is low and DIVPHA2CD1L is set to low Loads Output Divider 2 and Phase Adjust 2 into OUTPUT 2 CD1 PIN is low and DIVPHA2CD1L is set to high Loads Output Divider 1 and Phase Adjust 1 into OUTPUT 2	EEPROM
28	24	OUTBUF2CD2LX	CD2 Low	Output Buffer 2 Signaling Selection when CD2 in low (X,Y) = 01: LVPECL, 11: LVDS, 00: LVCMOS, 10: Output Disable	EEPROM
29	25	OUTBUF2CD2LY			
30	26	OUTBUF2CD2HX	CD2 High	Output Buffer 2 Signaling Selection when CD2 in high (X,Y) = 01: LVPECL, 11: LVDS, 00: LVCMOS, 10: Output Disable	EEPROM
31	27	OUTBUF2CD2HY			

Register 3: CD Mode

SPI BIT	RAM BIT	BIT NAME	RELATED BLOCK	DESCRIPTION/FUNCTION	POWER UP CONDITION
0		A0		Address 0	1
1		A1		Address 1	1
2		A2		Address 2	0
3		A3		Address 3	0
4	0	DIS_FDET_REF	PLL Freq. Detect	When set to 0, the REF-clock frequency detector is ON When set to 1, it is switched OFF	EEPROM
5	1	DIS_FDET_FB	Diagnostics	When set to 1, the feedback path frequency detector is switched OFF (TI Test-GTME)	EEPROM
6	2	BIAS_DIV01<0>	Output Divider 0 and 1	When BIAS_DIV01<1:0> = 00, No current reduction for all output-divider 01, Current reduction for all output-divider by about 20% 10, Current reduction for all output-divider by about 30%	EEPROM
7	3	BIAS_DIV01<1>			EEPROM
8	4	BIAS_DIV23<0>	Output Divider 2 and 3	When BIAS_DIV23<1:0> = 00, No current reduction for all output-divider 01, Current reduction for all output-divider by about 20% 10, Current reduction for all output-divider by about 30%	EEPROM
9	5	BIAS_DIV23<1>			EEPROM
10	6	PH3ADJC0	Output 3	Coarse phase adjust select for output divider 3	EEPROM
11	7	PH3ADJC1			
12	8	PH3ADJC2			
13	9	PH3ADJC3			
14	10	PH3ADJC4			
15	11	PH3ADJC5			
16	12	PH3ADJC6			
17	13	OUT3DIVRSEL0	Output 3	OUTPUT DIVIDER 3 Ratio Select (See Table 7)	EEPROM
18	14	OUT3DIVRSEL1			
19	15	OUT3DIVRSEL2			
20	16	OUT3DIVRSEL3			
21	17	OUT3DIVRSEL4			
22	18	OUT3DIVRSEL5			
23	19	OUT3DIVRSEL6			
24	20	EN3DIV	Output 3	When set to 0, the divider is disabled When set to 1, the divider is enabled	EEPROM
25	21	PECL3HISWING	Output 3	High Output Voltage Swing in LVPECL Mode if set to 1	EEPROM
26	22	DIVPHA3CD1H	CD1 High	CD1 PIN is high and DIVPHA3CD1H is set to low Loads Output Divider 3 and Phase Adjust 3 into OUTPUT 3 CD1 PIN is high and DIVPHA3CD1H is set to high Loads Output Divider 4 and Phase Adjust 4 into OUTPUT 3	EEPROM
27	23	DIVPHA3CD1L	CD1 Low	CD1 PIN is Low and DIVPHA3CD1L is set to low Loads Output Divider 3 and Phase Adjust 3 into OUTPUT 3 CD1 PIN is Low and DIVPHA3CD1L is set to high Loads Output Divider 4 and Phase Adjust 4 into OUTPUT 3	EEPROM
28	24	OUTBUF3CD2LX	CD2 Low	Output Buffer 3 Signaling Selection when CD2 in low (X,Y) = 01:LVPECL, 11: LVDS, 00: LVCMOS, 10: Output Disable	EEPROM
29	25	OUTBUF3CD2LY			
30	26	OUTBUF3CD2HX	CD2 High	Output Buffer 3 Signaling Selection when CD2 in high (X,Y) = 01: LVPECL, 11: LVDS, 00: LVCMOS, 10: Output Disable	EEPROM
31	27	OUTBUF3CD2HY			

Register 4: CD Mode

SPI BIT	RAM BIT	BIT NAME	RELATED BLOCK	DESCRIPTION/FUNCTION	POWER UP CONDITION
0		A0		Address 0	0
1		A1		Address 1	0
2		A2		Address 2	1
3		A3		Address 3	0
4	0	RESERVED			EEPROM
5	1	RESERVED			EEPROM
6	2	RESERVED			EEPROM
7	3	RESERVED			EEPROM
8	4	HOLDONLOR	HOLD- Over	If set to 1 it will 3-state the charge pump to act as a HOLD on Loss of Reference Clocks (Primary and Secondary)	EEPROM
9	5	RESERVED			EEPROM
10	6	PH4ADJC0	Output 4	Coarse phase adjust select for output divider 4	EEPROM
11	7	PH4ADJC1			
12	8	PH4ADJC2			
13	9	PH4ADJC3			
14	10	PH4ADJC4			
15	11	PH4ADJC5			
16	12	PH4ADJC6			
17	13	OUT4DIVRSEL0	Output 4	OUTPUT DIVIDER 4 Ratio Select (See Table 7)	EEPROM
18	14	OUT4DIVRSEL1			
19	15	OUT4DIVRSEL2			
20	16	OUT4DIVRSEL3			
21	17	OUT4DIVRSEL4			
22	18	OUT4DIVRSEL5			
23	19	OUT4DIVRSEL6			
24	20	EN4DIV	Output 4	When set to 0, the divider is disabled When set to 1, the divider is enabled	EEPROM
25	21	PECL4HISWING	Output 4	High Output Voltage Swing in LVPECL Mode if set to 1	EEPROM
26	22	DIVPHA4CD1H	CD1 High	CD1 PIN is high and DIVPHA4CD1H is set to low Loads Output Divider 4 and Phase Adjust 4 into OUTPUT 4 CD1 PIN is high and DIVPHA4CD1H is set to high Loads Output Divider 3 and Phase Adjust 3 into OUTPUT 4	EEPROM
27	23	DIVPHA4CD1L	CD1 Low	CD1 PIN is low and DIVPHA4CD1L is set to low Loads Output Divider 4 and Phase Adjust 4 into OUTPUT 4 CD1 PIN is low and DIVPHA4CD1L is set to high Loads Output Divider 3 and Phase Adjust 3 into OUTPUT 4	EEPROM
28	24	OUTBUF4CD2LX	CD2 Low	Output Buffer 4 Signaling Selection when CD2 in low (X,Y) = 01: LVPECL, 11: LVDS, 00: LVCMOS, 10: Output Disable	EEPROM
29	25	OUTBUF4CD2LY			
30	26	OUTBUF4CD2HX	CD2 High	Output Buffer 4 Signaling Selection when CD2 in high (X,Y) = 01: LVPECL, 11: LVDS, 00: LVCMOS, 10: Output Disable	EEPROM
31	27	OUTBUF4CD2HY			

Register 5: CD Mode

SPI BIT	RAM BIT	BIT NAME	RELATED BLOCK	DESCRIPTION/FUNCTION	POWER UP CONDITION
0		A0		Address 0	1
1		A1		Address 1	0
2		A2		Address 2	1
3		A3		Address 3	0
4	0	BIAS_DIV45<0>	Output Divider 4 and 5	When BIAS_DIV45<1:0> = 00, No current reduction for all output-divider 01, Current reduction for all output-divider by about 20% 10, Current reduction for all output-divider by about 30%	EEPROM
5	1	BIAS_DIV45<1>			
6	2	BIAS_DIV67<0>	Output Divider 6 and 7	When BIAS_DIV67<1:0> = 00, No current reduction for all output-divider 01, Current reduction for all output-divider by about 20% 10, Current reduction for all output-divider by about 30%	EEPROM
7	3	BIAS_DIV67<1>			
8	4	RESERVED			EEPROM
9	5	RESERVED			EEPROM
10	6	PH5ADJC0	Output 5	Coarse phase adjust select for output divider 5	EEPROM
11	7	PH5ADJC1			
12	8	PH5ADJC2			
13	9	PH5ADJC3			
14	10	PH5ADJC4			
15	11	PH5ADJC5			
16	12	PH5ADJC6			
17	13	OUT5DIVRSEL0	Output 5	OUTPUT DIVIDER 5 Ratio Select (See Table 7)	EEPROM
18	14	OUT5DIVRSEL1			
19	15	OUT5DIVRSEL2			
20	16	OUT5DIVRSEL3			
21	17	OUT5DIVRSEL4			
22	18	OUT5DIVRSEL5			
23	19	OUT5DIVRSEL6			
24	20	EN5DIV	Output 5	When set to 0, the divider is disabled When set to 1, the divider is enabled	EEPROM
25	21	PECL5HISWING	Output 5	High Output Voltage Swing in LVPECL Mode if set to 1	EEPROM
26	22	DIVPHA5CD1H	CD1 High	CD1 PIN is high and DIVPHA5CD1H is set to low Loads Output Divider 5 and Phase Adjust 5 into OUTPUT 5 CD1 PIN is high and DIVPHA5CD1H is set to high Loads Output Divider 6 and Phase Adjust 6 into OUTPUT 5	EEPROM
27	23	DIVPHA5CD1L	CD1 Low	CD1 PIN is low and DIVPHA5CD1L is set to low Loads Output Divider 5 and Phase Adjust 5 into OUTPUT 5 CD1 PIN is low and DIVPHA5CD1L is set to high Loads Output Divider 6 and Phase Adjust 6 into OUTPUT 5	EEPROM
28	24	OUTBUF5CD2LX	CD2 Low	Output Buffer 5 Signaling Selection when CD2 in low (X,Y) = 01: LVPECL, 11: LVDS, 00: LVCMOS, 10: Output Disable	EEPROM
29	25	OUTBUF5CD2LY			
30	26	OUTBUF5CD2HX	CD2 High	Output Buffer 5 Signaling Selection when CD2 in high (X,Y) = 01: LVPECL, 11: LVDS, 00: LVCMOS, 10: Output Disable	EEPROM
31	27	OUTBUF5CD2HY			

Register 6: CD Mode

SPI BIT	RAM BIT	BIT NAME	RELATED BLOCK	DESCRIPTION/FUNCTION	POWER UP CONDITION
0		A0		Address 0	0
1		A1		Address 1	1
2		A2		Address 2	1
3		A3		Address 3	0
4	0	FB_FD_DESEL	LOCK-DET	0 Feedback Frequency Detector is connected to the Lock Detector 1 Feedback Frequency Detector is disconnected from the Lock Detector	EEPROM
5	1	RESERVED		Set to "0"	
6	2	FBDETERM_DIV_SEL	FB-Divider / Deterministic Blocks	0 FB-Deterministic Clock divided by 1 1 FB- Deterministic Clock divided by 2	EEPROM
7	3	FBDETERM_DIV2_DIS		0 FB-Deterministic-DIV2-Block in normal operation 1 FB-Deterministic-DIV2 reset (here REG6_RB<2> == "0")	
8	4	FB_START_BYPASS		0 FB-Divider started with delay block (RC), normal operation 1 FB-Divider can be started with external REF_SEL-signal (pin)	
9	5	DET_START_BYPASS	All Output Dividers	0 Output-Dividers started with delay block (RC), normal operation 1 Output-Dividers can be started with external NRESET-signal (pin)	EEPROM
10	6	PH6ADJC0	Output 6	Coarse phase adjust select for output divider 6	EEPROM
11	7	PH6ADJC1			
12	8	PH6ADJC2			
13	9	PH6ADJC3			
14	10	PH6ADJC4			
15	11	PH6ADJC5			
16	12	PH6ADJC6			
17	13	OUT6DIVRSEL0	Output 6	OUTPUT DIVIDER 6 Ratio Select (See Table 7)	EEPROM
18	14	OUT6DIVRSEL1			
19	15	OUT6DIVRSEL2			
20	16	OUT6DIVRSEL3			
21	17	OUT6DIVRSEL4			
22	18	OUT6DIVRSEL5			
23	19	OUT6DIVRSEL6			
24	20	EN6DIV	Output 6	When set to 0, the divider is disabled When set to 1, the divider is enabled	EEPROM
25	21	PECL6HISWING	Output 6	High Output Voltage Swing in LVPECL Mode if set to 1	EEPROM
26	22	DIVPHA6CD1H	CD1 High	CD1 PIN is high and DIVPHA6CD1H is set to low Loads Output Divider 6 and Phase Adjust 6 into OUTPUT 6 CD1 PIN is high and DIVPHA6CD1H is set to high Loads Output Divider 5 and Phase Adjust 5 into OUTPUT 6	EEPROM
27	23	DIVPHA6CD1L	CD1 Low	CD1 PIN is low and DIVPHA6CD1L is set to low Loads Output Divider 6 and Phase Adjust 6 into OUTPUT 6 CD1 PIN is low and DIVPHA6CD1L is set to high Loads Output Divider 5 and Phase Adjust 5 into OUTPUT 6	EEPROM
28	24	OUTBUF6CD2LX	CD2 Low	Output Buffer 6 Signaling Selection when CD2 in low (X,Y) = 01: LVPECL, 11: LVDS, 00: LVCMOS, 10: Output Disable	EEPROM
29	25	OUTBUF6CD2LY			
30	26	OUTBUF6CD2HX	CD2 High	Output Buffer 6 Signaling Selection when CD2 in high (X,Y) = 01: LVPECL, 11: LVDS, 00: LVCMOS, 10: Output Disable	EEPROM
31	27	OUTBUF6CD2HY			

Register 7: CD Mode

SPI BIT	RAM BIT	BIT NAME	RELATED BLOCK	DESCRIPTION/FUNCTION	POWER UP CONDITION
0		A0		Address 0	1
1		A1		Address 1	1
2		A2		Address 2	1
3		A3		Address 3	0
4	0	LOCKW 0	LOCK-DET	Lock-detect window bit 0 (Refer to Reg 9 RAM Bits 6 and 7)	EEPROM
5	1	LOCKW 1		Lock-detect window bit 1 (Refer to Reg 9 RAM Bits 6 and 7)	
6	2	RESERVED		Set to 0	
7	3	LOCKC0		Number of coherent lock events bit 0	
8	4	LOCKC1		Number of coherent lock events bit 1	
9	5	ADLOCK		Selects Digital PLL_LOCK 0 ,Selects Analog PLL_LOCK 1	
10	6	PH7ADJC0	Output 7	Coarse phase adjust select for output divider 7	EEPROM
11	7	PH7ADJC1			
12	8	PH7ADJC2			
13	9	PH7ADJC3			
14	10	PH7ADJC4			
15	11	PH7ADJC5			
16	12	PH7ADJC6	Output 7	OUTPUT DIVIDER 7 Ratio Select (See Table 7)	EEPROM
17	13	OUT7DIVRSEL0			
18	14	OUT7DIVRSEL1			
19	15	OUT7DIVRSEL2			
20	16	OUT7DIVRSEL3			
21	17	OUT7DIVRSEL4			
22	18	OUT7DIVRSEL5	Output 7	When set to 0, the divider is disabled When set to 1, the divider is enabled	EEPROM
23	19	OUT7DIVRSEL6			
24	20	EN7DIV	Output 7	When set to 0, the divider is disabled When set to 1, the divider is enabled	EEPROM
25	21	PECL7HISWING	Output 7	High Output Voltage Swing in LVPECL Mode if set to 1	EEPROM
26	22	DIVPHA7CD1H	CD1 High	CD1 PIN is high and DIVPHA7CD1H is set to low Loads Output Divider 7 and Phase Adjust 7 into OUTPUT 7 CD1 PIN is high and DIVPHA7CD1H is set to high Loads Output Divider 8 and Phase Adjust 8 into OUTPUT 7	EEPROM
27	23	DIVPHA7CD1L	CD1 Low	CD1 PIN is low and DIVPHA7CD1L is set to low Loads Output Divider 7 and Phase Adjust 7 into OUTPUT 7 CD1 PIN is low and DIVPHA7CD1L is set to high Loads Output Divider 8 and Phase Adjust 8 into OUTPUT 7	EEPROM
28	24	OUTBUF7CD2LX	CD2 Low	Output Buffer 7 Signaling Selection when CD2 in low (X,Y) = 01: LVPECL, 11: LVDS, 00: LVCMOS, 10: Output Disable	EEPROM
29	25	OUTBUF7CD2LY			
30	26	OUTBUF7CD2HX	CD2 High	Output Buffer 7 Signaling Selection when CD2 in high (X,Y) = 01: LVPECL, 11: LVDS, 00: LVCMOS, 10: Output Disable	EEPROM
31	27	OUTBUF7CD2HY			

Register 8: CD Mode

SPI BIT	RAM BIT	BIT NAME	RELATED BLOCK	DESCRIPTION/FUNCTION	POWER UP CONDITION
0		A0		Address 0	0
1		A1		Address 1	0
2		A2		Address 2	0
3		A3		Address 3	1
4	0	VCXOBUFSELX	VCXO and AUX Input Buffers VCXO Input Buffer	VCXO and AUX Input Buffer Type Select (LVPECL, LVDS or LVCMOS)	EEPROM
5	1	VCXOBUFSELY		XY(10) LVPECL, (11) LVDS, (00) LVCMOS- Input is Positive Pin	
6	2	VCXOACDCSEL		If Set to 0 AC Termination, If set to 1 DC Termination	
7	3	VCXOHYSTEN		If Set to 1 Input Buffers Hysteresis enabled	
8	4	VCXOTERMSEL		If Set to 0 Input Buffer Internal Termination enabled	
9	5	VCXOINVB	VCXO Input Buffer	If Set to 1 It biases VCXO Input negative pin with internal VCXOVBB voltage	EEPROM
10	6	PH8ADJC0	Output 8 and 9	Coarse phase adjust select for output divider 8 and 9	EEPROM
11	7	PH8ADJC1			
12	8	PH8ADJC2			
13	9	PH8ADJC3			
14	10	PH8ADJC4			
15	11	PH8ADJC5			
16	12	PH8ADJC6			
17	13	OUT8DIVRSEL0	Output 8 and 9	OUTPUT DIVIDER 8 and 9 Ratio Select (See Table 7)	EEPROM
18	14	OUT8DIVRSEL1			
19	15	OUT8DIVRSEL2			
20	16	OUT8DIVRSEL3			
21	17	OUT8DIVRSEL4			
22	18	OUT8DIVRSEL5			
23	19	OUT8DIVRSEL6			
24	20	EN89DIV	Output 8 and 9	When set to 0, the divider is disabled When set to 1, the divider is enabled	EEPROM
25	21	PECL8HISWING	Output 8	High Output Voltage Swing in LVPECL Mode if set to 1	EEPROM
26	22	DIVPHA8CD1H	CD1 High	CD1 PIN is high and DIVPHA8CD1H is set to low Loads Output Divider 8 and Phase Adjust 8 into OUTPUT 8 CD1 PIN is high and DIVPHA8CD1H is set to high Loads Output Divider 7 and Phase Adjust 7 into OUTPUT 8	EEPROM
27	23	DIVPHA8CD1L	CD1 Low	CD1 PIN is low and DIVPHA8CD1L is set to low Loads Output Divider 8 and Phase Adjust 8 into OUTPUT 8 CD1 PIN is low and DIVPHA8CD1L is set to high Loads Output Divider 7 and Phase Adjust 7 into OUTPUT 8	EEPROM
28	24	OUTBUF8CD2LX	CD2 Low	Output Buffer 8 Signaling Selection when CD2 in low (X,Y) = 01: LVPECL, 11: LVDS, 00: LVCMOS, 10: Output Disable	EEPROM
29	25	OUTBUF8CD2LY			
30	26	OUTBUF8CD2HX	CD2 High	Output Buffer 8 Signaling Selection when CD2 in high (X,Y) = 01: LVPECL, 11: LVDS, 00: LVCMOS, 10: Output Disable	EEPROM
31	27	OUTBUF8CD2HY			

Register 9: CD Mode

SPI BIT	RAM BIT	BIT NAME	RELATED BLOCK	DESCRIPTION/FUNCTION	POWER UP CONDITION
0		A0		Address 0	1
1		A1		Address 1	0
2		A2		Address 2	0
3		A3		Address 3	1
4	0	HOLDF1	HOLD- Over	Enables the Frequency Hold-Over Function 1 on 1, off 0	EEPROM
5	1	HOLDF2		Enables the Frequency Hold-Over Function 2 on 1, off 0	
6	2	HOLD		3-State Charge Pump 0 - (equal to HOLD-Pin function)	
7	3	HOLDTR		HOLD function always activated "1" (recommended for test purposes, only) Triggered by analog PLL Lock detect outputs If analog PLL Lock Signal is [1] (PLL locked), HOLD is activated If analog PLL Lock Signal is [0] (PLL not lock), HOLD is deactivated	
8	4	HOLD_CNT0		HOLD1 Function is reactivated after X Ref Clock Cycles. Defined by (HOLD_CNT0,HOLD_CNT1)::X= Number of Clock Cycles. For (00)::X=64, (01)::X=128, (10)::X=256, (11)::X=512 Clock Cycles.	
9	5	HOLD_CNT1			
10	6	LOCKW 2	LOCK-DET	Extended Lock-detect window Bit 2 (Also refer to Reg 7 RAM Bits 0 and 1)	EEPROM
11	7	LOCKW 3		Extended Lock-detect window Bit 3 (Also refer to Reg 7 RAM Bits 0 and 1)	
12	8	NOINV_RESHTOL_INT	Chip CORE	When set to 0, SPI/HOLD_INT and SPI/RESET_INT inverted (default) When set to 1, SPI/HOLD_INT and SPI/RESET_INT not inverted	EEPROM
13	9	DIVSYNC_DIS	<i>Diagnostic: PLL N/M Divider</i>	<i>When GTME = 0, this bit has no functionality, But when GTME = 1, then: When set to 0, START-Signal is synchronized to N/M Divider Input Clocks When set to 1, START-Sync N/M Divider in PLL are bypassed</i>	EEPROM
14	10	START_BYPASS	Divider START DETERM-Block	When set to 0, START-Signal is synchronized to VCXO-Clock When set to 1, START-Sync Block is bypassed	EEPROM
15	11	INDET_BP	Divider START DETERM-Block	When set to 0, Sync Logic active when VCXO/AUX-Clocks are available When set to 1, Sync Logic is independent from VCXO- and/or AUX-Clocks	EEPROM
16	12	PLL_LOCK_BP	Divider START DETERM-Block	When set to 0, Sync Logic waits for 1st PLL_LOCK state When set to 1, Sync Logic independent from 1st PLL_LOCK	EEPROM
17	13	LOW_FD_FB_EN	Divider START DETERM-Block	When set to 0, Sync Logic is independent from VCXO/DIV_FB freq. (PLL-FD) When set to 1, Sync Logic is started for VCXO/DIV_FB > ~600KHz, stopped for VCXO/DIV_FB < ~600KHz	EEPROM
18	14	NPRESET_MDIV	PLL M/FB-Divider	When set to 0, M-Divider uses NHOLD1 as NPRESET When set to 1, M-Divider NOT preset by NHOLD1	EEPROM
19	15	BIAS_DIV_FB<0>	Feedback Divider	When BIAS_DIV_FB<1:0> = 00, No current reduction for FB-Divider 01, Current reduction for FB-Divider by about 20% 10, Current reduction for FB-Divider by about 30%	EEPROM
20	16	BIAS_DIV_FB<1>			
21	17	BIAS_DIV89<0>	Output Divider 8 and 9	When BIAS_DIV89<1:0> = 00, No current reduction for all output-divider 01, Current reduction for all output-divider by about 20% 10, Current reduction for all output-divider by about 30%	EEPROM
22	18	BIAS_DIV89<1>			
23	19	AUXINVBB	AUX Buffer	If Set to 1 it Biases AUX Input Negative Pin with internal VCXOVBB voltage.	EEPROM
24	20	DIS_AUX_Y9		If Set to 1 AUX in input Mode Buffer is disabled. If Set to 0 it follows the behavior of FB_MUX_SEL and OUT_MUX_SEL bits settings.	
25	21	PECL9HISWING	Output 9	High Output Voltage Swing in LVPECL Mode if set to 1	EEPROM
26	22	RESERVED			EEPROM
27	23	RESERVED			EEPROM
28	24	OUTBUF9CD2LX	CD2 Low	Output Buffer 9 Signaling Selection when CD2 in low (X,Y) = 01: LVPECL, 11: LVDS, 00: LVCMOS, 10: Output Disable	EEPROM
29	25	OUTBUF9CD2LY			
30	26	OUTBUF9CD2HX	CD2 High	Output Buffer 9 Signaling Selection when CD2 in high (X,Y) = 01: LVPECL, 11: LVDS, 00: LVCMOS, 10: Output Disable	EEPROM
31	27	OUTBUF9CD2HY			

Register 10: CD Mode

SPI BIT	RAM BIT	BIT NAME	RELATED BLOCK	DESCRIPTION/FUNCTION	POWER UP CONDITION
0		A0		Address 0	0
1		A1		Address 1	1
2		A2		Address 2	0
3		A3		Address 3	1
4	0	M0	Reference (PRI/SEC) Divider M	Reference Divider M bit 0	EEPROM
5	1	M1		Reference Divider M bit 1	
6	2	M2		Reference Divider M bit 2	
7	3	M3		Reference Divider M bit 3	
8	4	M4		Reference Divider M bit 4	
9	5	M5		Reference Divider M bit 5	
10	6	M6		Reference Divider M bit 6	
11	7	M7		Reference Divider M bit 7	
12	8	M8		Reference Divider M bit 8	
13	9	M9		Reference Divider M bit 9	
14	10	M10		Reference Divider M bit 10	
15	11	M11		Reference Divider M bit 11	
16	12	M12		Reference Divider M bit 12	
17	13	M13		Reference Divider M bit 13	
18	14	N0	VCXO/AUX/SEC Divider N	VCXO Divider N bit 0	EEPROM
19	15	N1		VCXO Divider N bit 1	
20	16	N2		VCXO Divider N bit 2	
21	17	N3		VCXO Divider N bit 3	
22	18	N4		VCXO Divider N bit 4	
23	19	N5		VCXO Divider N Bit 5	
24	20	N6		VCXO Divider N Bit 6	
25	21	N7		VCXO Divider N Bit 7	
26	22	N8		VCXO Divider N Bit 8	
27	23	N9		VCXO Divider N Bit 9	
28	24	N10		VCXO Divider N Bit 10	
29	25	N11		VCXO Divider N Bit 11	
30	26	N12		VCXO Divider N Bit 12	
31	27	N13		VCXO Divider N Bit 13	

Register11: CD Mode

SPI BIT	RAM BIT	BIT NAME	RELATED BLOCK	DESCRIPTION/FUNCTION	POWER UP CONDITION
0		A0		Address 0	1
1		A1		Address 1	1
2		A2		Address 2	0
3		A3		Address 3	1
4	0	PRI_DIV2	Input Buffers	If set to 1 Enables Primary Reference Divide by 2	EEPROM
5	1	SEC_DIV2	Input Buffers	If set to 1 Enables Secondary Reference Divide by 2	EEPROM
6	2	FB_DIS	FB Path Integer Counter 32	When set to 0, FB divider is active When set to 1, FB divider is disabled	EEPROM
7	3	FB_CML_SEL	FB Path Integer Counter 32	When set to 0, FB clock is CMOS type When set to 1, FB clock is CML type and uses CML2CMOS converter in PLL	EEPROM
8	4	FB_INCLK_INV	FB-Divider / Deterministic Blocks	When set to 0, Input clock for FB not inverted (normal mode, low speed) When set to 1, Input clock for FB inverted (higher speed mode)	EEPROM
9	5	FB_COUNT32_0	FB Path Integer Counter 32 (P divider)	Feedback Counter Bit0	EEPROM
10	6	FB_COUNT32_1		Feedback Counter Bit1	
11	7	FB_COUNT32_2		Feedback Counter Bit2	
12	8	FB_COUNT32_3		Feedback Counter Bit3	
13	9	FB_COUNT32_4		Feedback Counter Bit4	
14	10	FB_COUNT32_5		Feedback Counter Bit5	
15	11	FB_COUNT32_6		Feedback Counter Bit6	
16	12	FB_PHASE0	FB Path Integer Counter 32 (P Divider)	Feedback Phase Adjust Bit0	EEPROM
17	13	FB_PHASE1		Feedback Phase Adjust Bit1	
18	14	FB_PHASE2		Feedback Phase Adjust Bit2	
19	15	FB_PHASE3		Feedback Phase Adjust Bit3	
20	16	FB_PHASE4		Feedback Phase Adjust Bit4	
21	17	FB_PHASE5		Feedback Phase Adjust Bit5	
22	18	FB_PHASE6		Feedback Phase Adjust Bit6	
23	19	PD_PLL	PLL	If set to 0, PLL is in normal mode If set to 1, PLL is powered down	EEPROM
24	20	FB_MUX_SEL Table 8	Clock Tree and Deterministic Block	When set to 0, the VCXO Clock is selected for the Clock Tree and FB-Div/Det When set to 1, the AUX Clock is selected for the Clock Tree and FB-Div/Det.	EEPROM
25	21	OUT_MUX_SEL Table 8		If Set to 0 it selects the VCXO Clock and if Set to 1 it selects the AUX Clock	EEPROM
26	22	FB_SEL	Diagnostics	<i>Feed Back Path Selects FB/VCXO-Path when set to 0 (TI Test-GTME) The Secondary Reference clock input is selected when set to 1 (TI Test-GTME)</i>	EEPROM
27	23	NRESHAPE1	Reference Selection Control	Reshapes the Reference Clock Signal 0, Disable Reshape 1	EEPROM
28	24	SEL_DEL1		If set to 0 it enables short delay for fast operation If Set to 1 Long Delay recommended for input references below 150Mhz.	
29	25	RESET_HOLD	Reset Circuitry	If set to 1 the RESET or HOLD pin acts as $\overline{\text{HOLD}}$, set to 0 it acts as $\overline{\text{RESET}}$.	EEPROM
30	26	EPUNLOCK	Status	EEPROM Unlock	EEPROM
31	27	EPSTATUS	Status	EEPROM Status	EEPROM

Table 8. Output Buffers Source Feed, PLL Source Feed, and AUX IN/OUTPUT 9 Selection

FB_MUX_SEL	OUT_MUX_SEL	PLL FEED AND OUTPUT FEED	AUX INPUT OR OUTPUT 9
0	0	VCXO::PLL, VCXO::Y0...Y9 and Deterministic Block	OUTPUT 9 is Enabled ⁽¹⁾
1	0	AUXIN::PLL, VCXO::Y0...Y8 and Deterministic Block	AUX IN is Enabled
0	1	VCXO::PLL, AUXIN::Y0...Y8 and Deterministic Block	AUX IN is Enabled
1	1	AUXIN::PLL, AUXIN::Y0...Y8 and Deterministic Block	AUX IN is Enabled

(1) Default

INTERFACE, CONFIGURATION, AND CONTROL

The CDCE72010 is designed to support various applications with SPI bus interface and without. In the case where systems lack the SPI bus or a Boot up configuration is required at start up before the management layer is up the built in EEPROM is used to provide this function.

The Interface bus takes the serialized address and data and writes to the specified RAM bits. The content of the RAM bits are connected to logical functions in the device. Changing the content of the RAM bits (high or low) instantly changes the logical functions inside the device.

At power up or after power down is de-asserted the contents of the EEPROM bits are copied to their corresponding RAM bits. After that the content of RAM can be changed via the SPI bus. When writing to EEPROM commands are detected on the SPI bus the control logic begins writing the content of the RAM bits into the corresponding EEPROM bits. This process takes about 50ms. During this time the power supply should be above 3.2V.

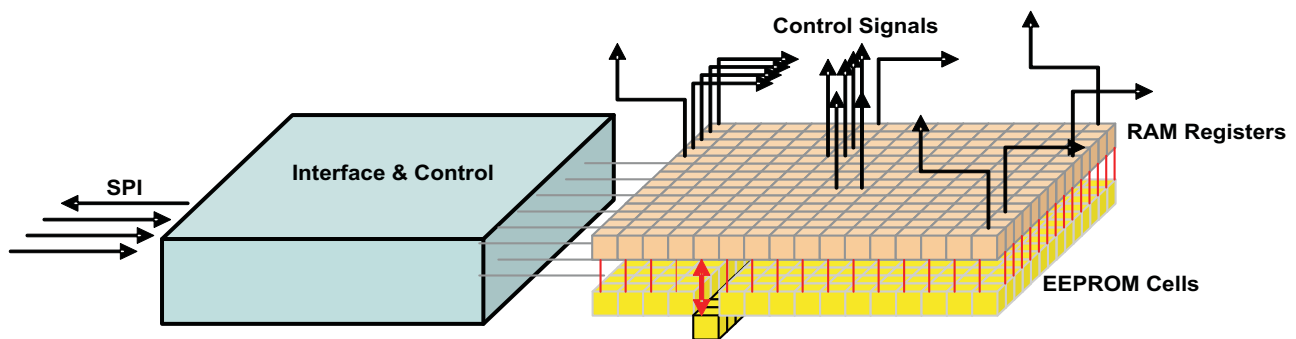

Figure 15. Interface Control

UNIVERSAL INPUT AND REFERENCE CLOCK BUFFERS

The CDCE72010 is designed to support what is referred to as a Universal Input Buffer structure. This type of buffer is designed to accept Differential or single ended inputs and it is sensitive enough to act as a LVPECL or LVDS in differential mode and LVCMOS in Single ended mode. With the proper external termination various types of inputs signals can be supported. Those inputs will be discussed in a separate document (application Notes).

The CDCE72010 has two internal voltage biasing circuitries. One to set the termination voltage for references (PRI_REF and SEC_REF) and the second biasing circuitry is to set the termination voltage to the VCXO_IN and AUX_IN. This means that we can only have one type of differential signal on PRI_REF and SEC_REF and only one type of differential signal on VCXO_IN and AUX_IN.

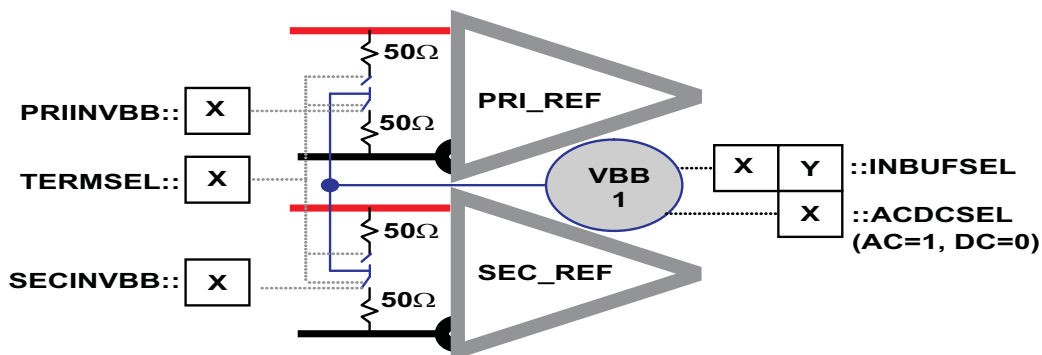

Figure 16. PRI_REF AND SEC_REF Voltage Biasing Circuitry

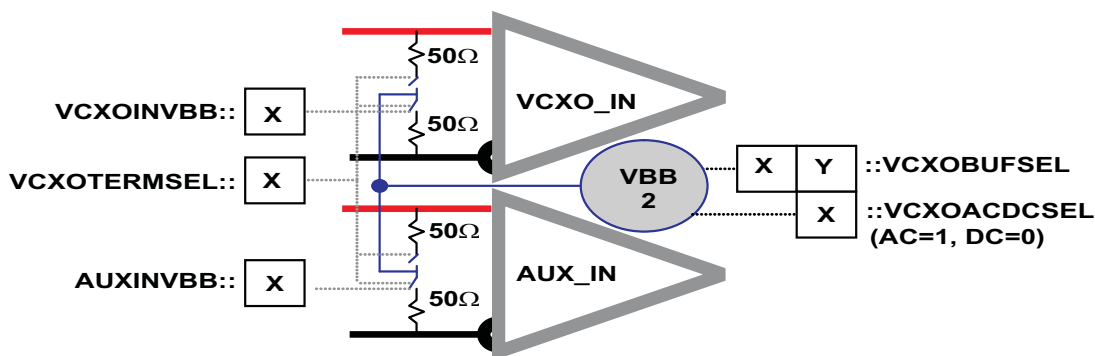

Figure 17. VCXO_IN and AUX_IN Voltage Biasing Circuitry

AUTOMATIC/MANUAL REFERENCE CLOCK SWITCHING (SMART MUX)

The CDCE72010 supports two reference clock inputs, the primary clock input, PRI_REF, and the secondary clock input, SEC_REF. The clocks can be selected manually or automatically. The respective mode is selected by the dedicated SPI register. In the manual mode the external REF_SEL signal selects one of the two input clocks

In the automatic mode the primary clock is selected by default even if both clocks are available. In case the primary clock is not available or fails, then the input switches to the secondary clock until the primary clock is back. The figure below shows the automatic clock selection.

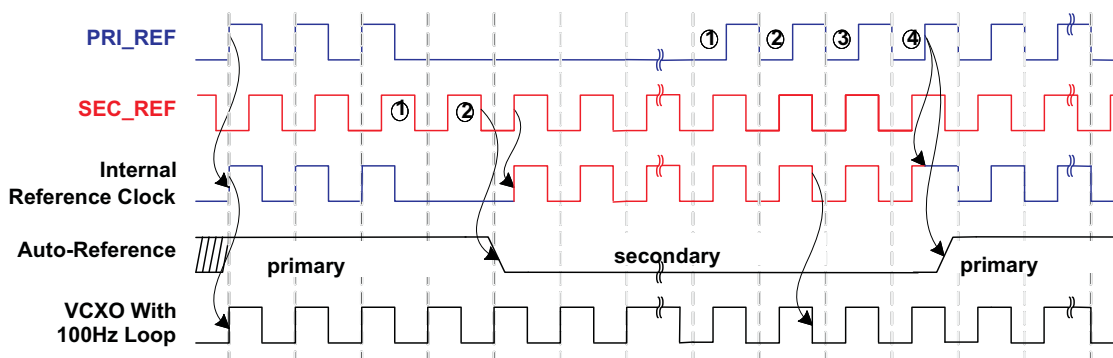

Figure 18. Automatic Clock Select Timing

In the automatic mode the frequencies of both clock signals has to be similar but may differ by up to 20%. There is no limitation placed on the phase relationship between the two inputs.

The clock input circuitry is designed to suppress glitches during switching between the primary and secondary clock in the manual and automatic mode. This insures that the clock outputs continue to clock reliably when a transition from a clock input occurs.

The phase of the output clock will slowly follow the new input phase. The speed of this transition is determined by the loop bandwidth. However, there is no phase build-out function supported (like in SONET/SDH applications).

PHASE FREQUENCY DETECTOR

The main function of the CDCE72010 device is to synchronize a Voltage Control Oscillator (VCO) or a Voltage Control Crystal Oscillator (VCXO) output to a reference clock input. The phase detector compares 2 signals and outputs the difference between them. It is symbolized by an XOR. The compared signals are derived from the Reference clock and from the VCO/VCXO clocks. The Reference clock is divided by the “R” Divider (1 or 2) and “M” divider (14 Bits) and presented to the PFD. The VCO/VCXO clock is divided by the Feedback Divider (1 to 80) and the “N” Divider (14 Bits) and presented to the PFD.

$$\text{Frequency (VCXO_IN or AUX_IN) / Frequency (PRI_REF or SEC_REF)} = (R * M) / (P * N)$$

P is the product of X Divider and FB Divider R and X Divider is set to be divide by 1 or 2

The PFD is a classical style with UP and DOWN signals generating flip-flops and a common reset path. Some special functions were implemented:

- Bit CP_DIR (register 0 RAM bit<9> can swap internally the REF- and FB-CLK inputs to the PFD flip-flops.
- The reset path can be typically delayed with the bits DELAY_PFD <1:0> (register 0 RAM bit<7:6>) from 1.5ns to 6.0ns.

PFD Pulse Width Delay (Register 0 RAM Bits [7:6])

The “PFD pulse width delay” gets around the dead zone of the PFD transfer function and reduces phase noise and reference spurs.

Table 9. PFD Pulse Width Delay

PFD1	PFD0	PFD PULSE WIDTH DELAY
0	0	1.5ns ⁽¹⁾
0	1	3.0ns
1	0	4.5ns
1	1	6.0ns

(1) Default

The PFD receives two clocks of the similar frequencies and decides if one is lagging or leading. This Lagging/Leading signals are feed to the Charge Pump. The Charge Pump in its turn takes the Lagging/Leading signals and translate them into current pulses that are feed to the external filter. The Output of the external filter is a DC level that controls the Voltage reference of the VCO/VCXO sitting outside and feeding the CDCE72010 at the VCXO Input. The VCO/VCXO drifts its outputs frequency with respect to the voltage applied to its Voltage Control pin. This is how the loop is closed.

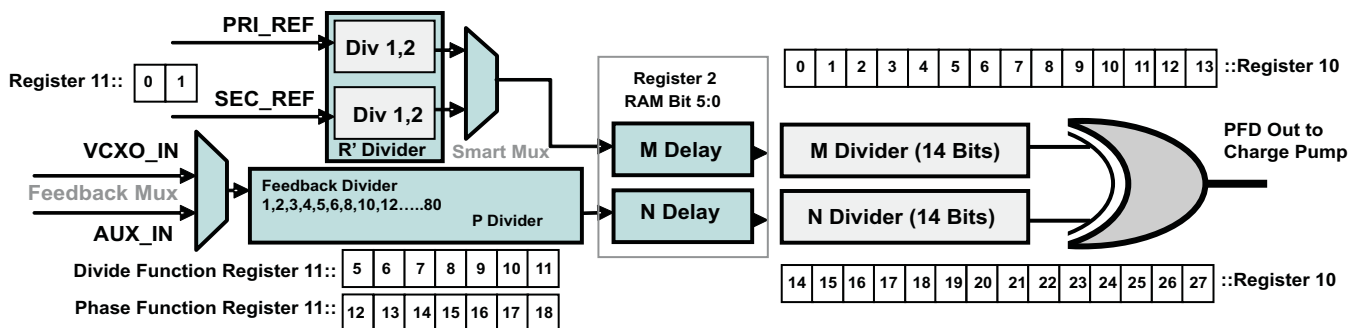

Figure 19. Phase Frequency Detection

Table 10. Feedback Divider Settings

FEEDBACK DIVIDER SETTINGS (REGISTER 11: BITS)							DIVIDER SETTING
11	10	9	8	7	6	5	
0	1	0	0	0	0	0	1
1	0	0	0	0	0	0	2
1	0	0	0	0	0	1	3
1	0	0	0	0	1	0	4
1	0	0	0	0	1	1	5
0	0	0	0	0	0	0	4'
0	0	0	0	0	0	1	6
0	0	0	0	0	1	0	8
0	0	0	0	0	1	1	10
0	0	0	0	1	0	0	8'
0	0	0	0	1	0	1	12
0	0	0	0	1	1	0	16
0	0	0	0	1	1	1	20
0	0	0	1	0	0	0	12'
0	0	0	1	0	0	1	18
0	0	0	1	0	1	0	24
0	0	0	1	0	1	1	30
0	0	0	1	1	0	0	16'
0	0	0	1	1	0	1	24'
0	0	0	1	1	1	0	32
0	0	0	1	1	1	1	40
0	0	1	0	0	0	0	20'
0	0	1	0	0	0	1	30'
0	0	1	0	0	1	0	40'
0	0	1	0	0	1	1	50
0	0	1	0	1	0	0	24'
0	0	1	0	1	0	1	36
0	0	1	0	1	1	0	48
0	0	1	0	1	1	1	60
0	0	1	1	0	0	0	28
0	0	1	1	0	0	1	42
0	0	1	1	0	1	0	56
0	0	1	1	0	1	1	70
0	0	1	1	1	0	0	32'
0	0	1	1	1	1	0	48'
0	0	1	1	1	1	1	64
0	0	1	1	1	1	1	80

PHASE DELAY FOR M AND N

Delay Block in M/N Path

Table 11. Reference Delay M (PRI_REF or SEC_REF) and Feedback Delay N (VCXO) Phase Adjustment (Register 2 RAM Bits [5:0]) ⁽¹⁾

DLYM2/DLYN2	DLYM1/DLYN1	DLYM0/DLYN0	PHASE OFFSET
0	0	0	0ps ⁽²⁾
0	0	1	±160ps
0	1	0	±320ps
0	1	1	±480ps
1	0	0	±830ps
1	0	1	±1130ps
1	1	0	±1450ps
1	1	1	±1750ps

(1) If Progr Delay M is set, all Yx outputs are lagging to the Reference Clock according to the value set. If Progr Delay N is set, all Yx outputs are leading to the Reference Clock according to the value set. Above are typical values at V_{CC} = 3.3 V, T_A = 25°C, PECL-output relate to Div4 mode.

(2) Default

Table 12. Reference Divider M/N 14-Bit (Register 10 RAM Bits [13:0] for M and RAM Bits [27:14] for N)

N13	N12	N11	N10	N9	N8	N7	N6	N5	N4	N3	N2	N1	N0	DIV BY ⁽¹⁾
0	0	0	0	0	0	0	0	0	0	0	0	0	0	1
0	0	0	0	0	0	0	0	0	0	0	0	0	1	2
0	0	0	0	0	0	0	0	0	0	0	0	1	0	3
0	0	0	0	0	0	0	0	0	0	0	0	1	1	4
								•						
								•						
								•						
0	0	0	0	0	0	0	1	1	1	1	1	1	1	128 ⁽²⁾
								•						
								•						
1	1	1	1	1	1	1	1	1	1	1	1	0	1	16382
1	1	1	1	1	1	1	1	1	1	1	1	1	0	16383
1	1	1	1	1	1	1	1	1	1	1	1	1	1	16384

(1) If the divider value is Q, then the code will be the binary value of (Q - 1).

(2) Default

CHARGE PUMP

The Charge Pump drives the loop filter that controls the external VCO/VCXO. The Charge pump frequency is determined by the PFD frequency since the function of the charge pump is to translate the UP DOWN signals of the PFD into current pulses that drives the external filter. The Charge pump current is set by the control vector ICP [3:0]. The error amplifier operates from 0.7V to the V_{DD} supply voltage. See the table below for ICP settings.

Table 13. CP, Charge Pump Current (Register 0 RAM Bits [17:14])

ICP3	ICP2	ICP1	ICP0	TYPICAL CHARGE PUMP CURRENT
0	0	0	0	0 μ A (3-State)
0	0	0	1	200 μ A
0	0	1	0	400 μ A
0	0	1	1	600 μ A
0	1	0	0	800 μ A
0	1	0	1	1.0 mA
0	1	1	0	1.2 mA
0	1	1	1	1.4 mA
1	0	0	0	1.6 mA
1	0	0	1	1.8 mA
1	0	1	0	2.0 mA
1	0	1	1	2.2 mA ⁽¹⁾
1	1	0	0	2.4 mA
1	1	0	1	2.6 mA
1	1	1	0	2.8 mA
1	1	1	1	3.0 mA

(1) Default

The 'Preset Charge-Pump to $V_{CC_CP}/2$ is a useful feature to quickly set the center frequency of the VC(X)O after Power-up or Reset. The adequate control voltage for the VC(X)O will be provided to the Charge-Pump output by an internal voltage divider of 1K Ω /1K Ω to V_{CC_CP} and GND ($V_{CC_CP}/2$).

This feature helps to get the initial frequency accuracy, i.e. required at CPRI (Common Public Radio Interface) or OBSAI (Open Base Station Architecture Initiative).

The Preset Charge-Pump to $V_{CC_CP}/2$ can be set and reset by SPI register.

Charge-Pump Current Direction

The direction of the charge-pump (CP) current pulse can be changed by the SPI register settings. It determines in which direction CP current will regulate (Reference Clock leads to Feedback Clock). Most applications use the positive CP output current (power-up condition) because of the use of a passive loop filter. The negative CP current is useful when using an active loop filter concept with inverting operational amplifier. The Figure below shows the internal PFD signal and the corresponding CP current.

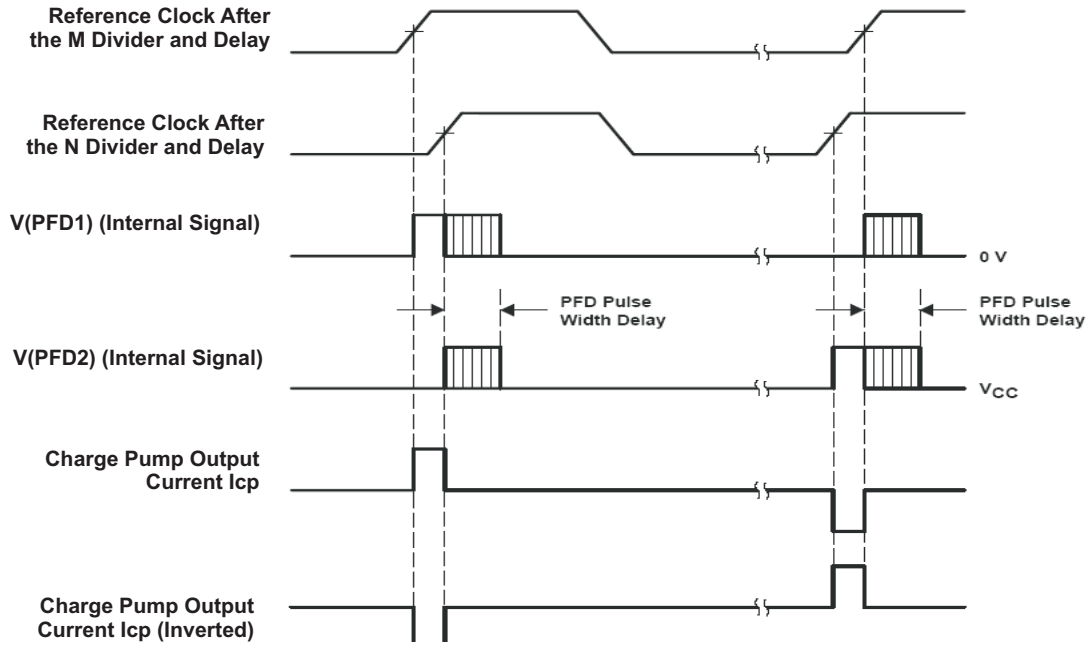

PFD pulse width delay improves spurious suppression.

Figure 20. Charge Pump

PLL LOCK FOR ANALOG AND DIGITAL DETECT

The CDCE72010 supports two PLL Lock indications: the digital lock signal or the analog lock signal. Both signals indicate logic high-level at PLL_LOCK if the PLL locks according the selected lock condition.

The PLL is locked (set high), if the rising edge of the Reference Clock (PRI_REF or SEC_REF clock) and Feedback Clock (VCXO_IN clock) at the PFD (Phase Frequency Detect) are inside a predefined lock detect window for a pre-defined number of successive clock cycles.

The PLL is out-of-lock (set low), if the rising edge of the Reference Clock (PRI_REF or SEC_REF clock) and Feedback Clock (VCXO_IN clock) at the PFD are outside the predefined lock detect window.

Both, the lock detect window and the number of successive clock cycles are user definable in the SPI register settings.

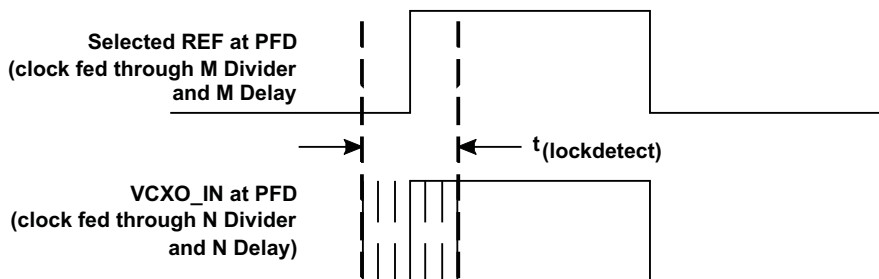

Figure 21. PLL Lock

The lock detect window describes the maximum allowed time difference for lock detect between the rising edge of PRI_REF or SEC_REF and VCXO_IN. The time difference is detected at the phase frequency detector. The rising edge of PRI_REF or SEC_REF is taken as reference. The rising edge of VCXO_IN is outside the lock detect window, if there is a phase displacement of more than $+0.5 \cdot t_{(\text{lockdetect})}$ or $-0.5 \cdot t_{(\text{lockdetect})}$.

Table 14. Lock-Detect Window (Register 7 RAM Bits [1:0] and Register 9 RAM Bits [7:6])

LOCKW3 [7]	LOCKW2 [6]	LOCKW1 [1]	LOCKW0 [0]	PHASE-OFFSET AT PFD-INPUT ⁽¹⁾
0	0	0	0	1.5 ns
1	1	0	1	5.8 ns ⁽²⁾
0	0	1	0	15.1 ns
0	0	1	1	Reserved
0	1	0	0	3.4 ns
0	1	0	1	7.7 ns
0	1	1	0	17.0 ns
0	1	1	1	Reserved
1	0	0	0	5.4 ns
1	0	0	1	9.7 ns
1	0	1	0	19.0 ns
1	0	1	1	Reserved
1	1	0	0	15.0 ns
1	1	0	1	19.3 ns
1	1	1	0	28.6 ns
1	1	1	1	Reserved

(1) Typical values at $V_{CC} = 3.3\text{ V}$, $T_A = 25^\circ\text{C}$

(2) Default

Table 15. Number of Successive Lock Events Inside the Lock Detect Window (Register 7 RAM Bits [4:3]) the PLL Lock Signal is Delayed for Number of FB_CLK Events

LOCKC1	LOCKC0	NO. OF SUCCESSIVE LOCK EVENTS
0	0	1
0	1	16
1	0	64 ⁽¹⁾
1	1	256

(1) Default

DIGITAL LOCK DETECT

When selecting the digital PLL lock option, PLL_LOCK will possibly jitter several times between lock and out of lock until a stable lock is detected. A single “low-to-high” step can be reached with a wide lock detect window and high number of successive clock cycles. PLL_LOCK will return to out of lock if just one cycle is outside the lock detect window.

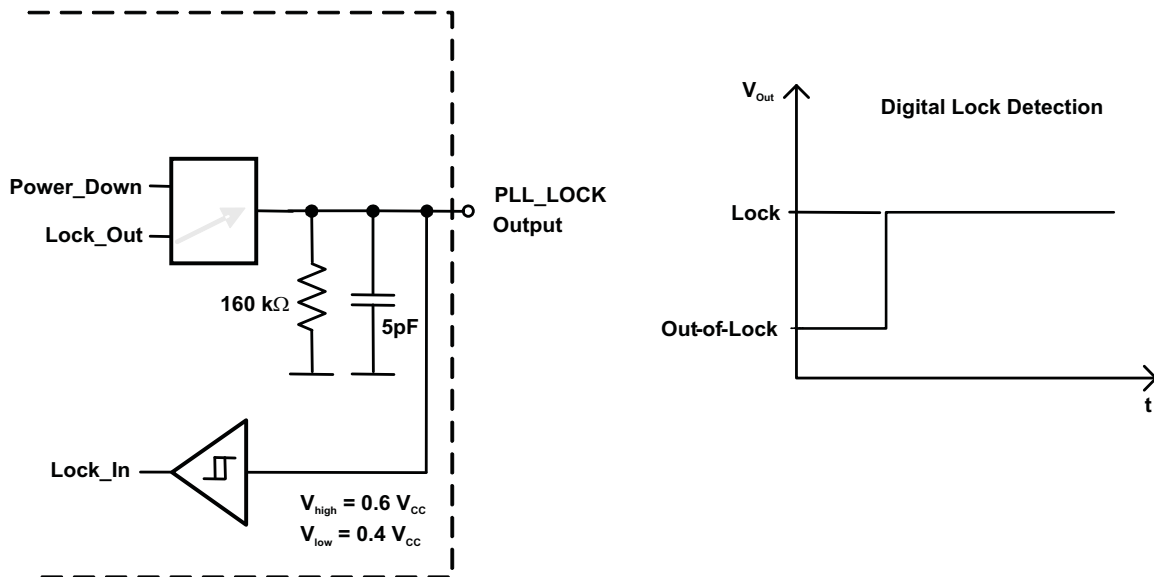

Figure 22. Digital Lock

ANALOG LOCK DETECT

When selecting the analog PLL Lock option, the high-pulses load the external capacitor via the internal $110\ \mu\text{A}$ current source until logic high-level is reached. Therefore, more time is needed to detect logic high level, but jittering of PLL_LOCK will be suppressed like possible in case of digital lock. The time PLL_LOCK needs to return to out of lock depends on the level of V_{OUT} , when the current source starts to unload the external capacitor.

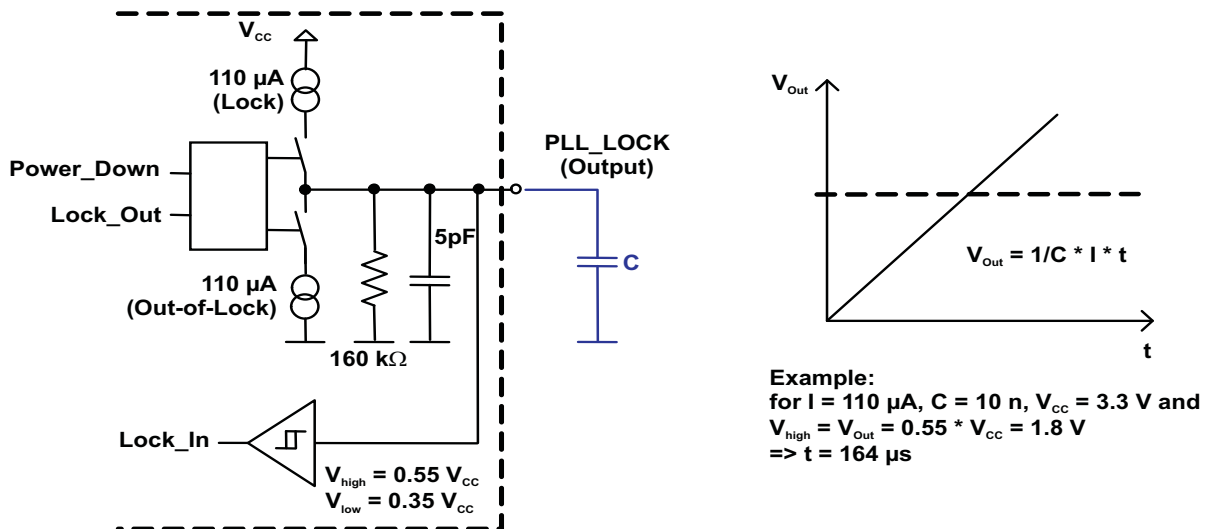

Figure 23. Analog Lock

FREQUENCY HOLD-OVER MODE

The HOLD-Function is a CDCE72010 feature that helps to improve system reliability. The HOLD-Function holds the output frequency in case the input reference clock fails or is disrupted. During HOLD, the Charge-Pump is switched off (3-State) freezing the last valid output frequency. The Hold-Function will be released after a valid reference clock is reapplied to the clock input and detected by the CDCE72010. For proper HOLD function, the Analog PLL-Lock-Detect mode has to be active. The following settings are involved with the HOLD Function:

- Lock Detect Window: Defines the window in ns in which the Lock is valid. The size is 3.5ns, 8.5ns, 18.5ns. Lock is set if Reference Clock and Feedback Clock are inside this predefined Lock-Detect Window for a pre-selected number of successive cycles.
- Out-of-Lock: Defines the out-of-lock condition: If the Reference Clock and the Feedback Clock at the PFD are outside the predefined Lock Detect Window.
- Number of Clock Cycles: Defines the number of successive PFD cycles which have to occur inside the lock window to set Lock detect. This does not apply for Out-of-Lock condition.
- Hold-Function: Selects HOLD-Function (see more details below).
- Hold-Trigger: Defines whether the HOLD-Function is always activated or whether it is dependent on the state of the analog PLL Lock detect output. In the latter case, HOLD is activated if Lock is set (high) and de-activated if Lock is reset (low).
- Analog PLL Lock Detect: Analog Lock output charges or discharges an external capacitor with every valid Lock cycle. The time constant for Lock detect can be set by the value of the capacitor.

The CDCE72010 supports two types of HOLD functions, one external controllable $\overline{\text{HOLD}}$ mode and one internal mode, HOLD.

EXTERNAL/HOLD FUNCTION

The Charge Pump can directly be switched into 3-State. This function is also available via SPI register. If logic low is applied to HOLD pin the Charge Pump will be switched to 3-State. After HOLD pin is released, the charge pump is switched back in to normal operation, with the next valid reference clock cycle at PRI_REF or SEC_REF and the next valid feedback clock cycle at the PFD. During HOLD, all divider and all outputs are at normal operation.

INTERNAL/HOLD FUNCTION

In Internal HOLD Function or HOLD-Over-Function the PLL has to be in lock to start the HOLD function. It switches the Charge Pump in to 3-State when an 'out-of-lock' event occurs. Then it starts a locking sequence of 64 cycles before it goes back to the beginning of the HOLD-Over loop.

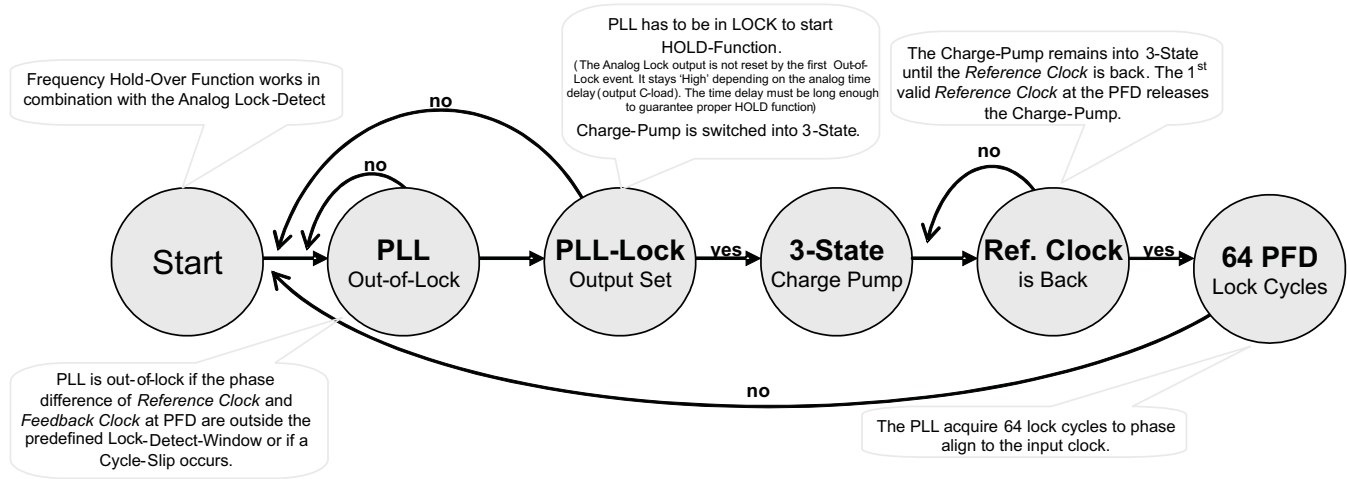

Figure 24. Frequency Hold Over

OUTPUT DIVIDERS AND PHASE ADJUST

The CDCE72010 is designed with individual Output Dividers for Outputs 1 to 8. Output Divider 1 drives Output 1 and Output 0 and Output Divider 8 drives Output 8 and Output 9. Each output divider has a bypass function or it is referred to as divide by “one”. Since divide by one bypasses the divider block it can address higher operating frequencies.

The output divider is designed to address divide by 1, 2, 3, 4, 5, 6, 8, 10, 12, 16, 18, 20, 24, 28, 30, 32, 36, 40, 42, 48, 50, 56, 60, 64, 70 and 80. The output divider includes a coarse phase adjust that shifts the divided clock signal. The phase adjust resolution is a function of the divide function. The maximum number of phase steps equals to the divider setting.

If the output is divide by 2, then two phase adjustment settings (0 and 180 degrees) are available. The resolution of phase adjustment is related to the output divider setting by the following: Phase adjust resolution = (1/Output Divider settings) X 360 Degrees.

Example: For a 491.52MHz VCXO where one of the outputs of the device is set to divide by 16 for a 30.72MHz desired output, this will mean that the 30.72MHz clock will have $(1/16) \times 360 = 22.5$ Degrees of phase adjustment resolution.

Output Divide Select (OUT#DIVSEL#) and Coarse Phase Adjust Select (PH#ADJC#) registers are located in Register 1 through 8 for Output 1 through 8 respectively.

The Phase difference between 2 divider settings on different output can be calculated using the following formula and referring to the Phase Lag number in the Output Divider Table (see [Table 7](#)).

Integer Remainder of $[(\text{Phase Lag X} - \text{Phase Lag Y}) / \text{Divide X}]$ as an example if we need to calculate the phase difference between divide by 4 and divide by 8 with respect to divide by 4 clock.

The Integer Remainder $[(28.5 - 0.5)/4] = 0$. This means there is 0 Cycle phase delay between Divide by 4 and Divide by 8 with respect to Divide by 4 Clock.

If we need to do the same calculation with respect to Divide by 8 we will have Integer Remainder $[(28.5 - 0.5)/8] = 0.5$ that means that there is 0.5 Cycles between Divide by 4 and divide by 8 with respect to a divide by 8 clock.

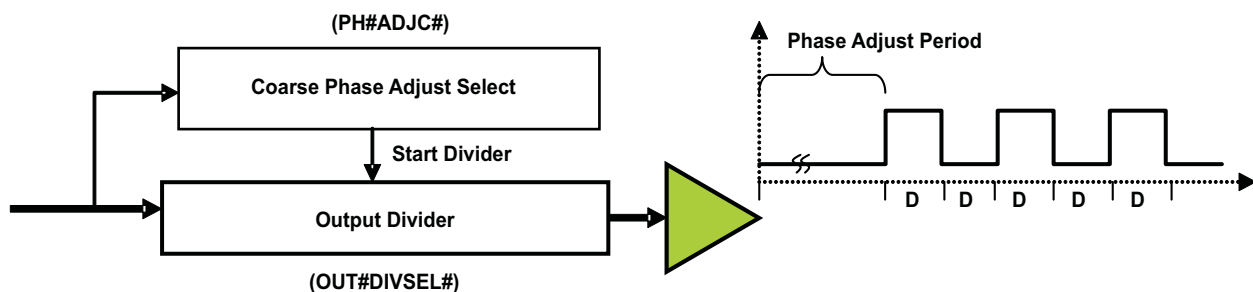

Figure 25. Maximum Output Frequency With Phase Alignment

For a complete listing of the coarse phase adjust settings, refer to the "CDCE72010 Coarse Phase Adjust" document.

DEVICE LAYOUT

The CDCE72010 is a high performance device packaged in a QFN-64. The die has all the ground pins bounded to the thermal PAD on the bottom of the package. Therefore it is essential that the connection from the thermal PAD to the ground layers should be low impedance. In addition, the thermal path in a QFN package is via the thermal PAD on the bottom of the package. Therefore, the layout of the PAD is very important and it will affect the thermal performance as well as the overall performance of the device. The illustration shown provides optimal performance in terms of thermal issues, inductance and power supply bypassing. The 10 X 10 Filled VIA pattern recommended allows for a low inductance connection between the thermal ground pad and the ground plane of the board. This pattern forms a low thermal resistive path for the heat generated by the die to get dissipated through the ground plane and to the exposed bottom side ground pad. It is recommended that solder mask not be used on this bottom side pad to maximize its effectiveness as a thermal heat sink. The recommended layout drives the thermal conductivity to 22.8 C/W in still air and 13.8 C/W in a 100LFM air flow if implemented on a JEDEC compliant test thermal board.

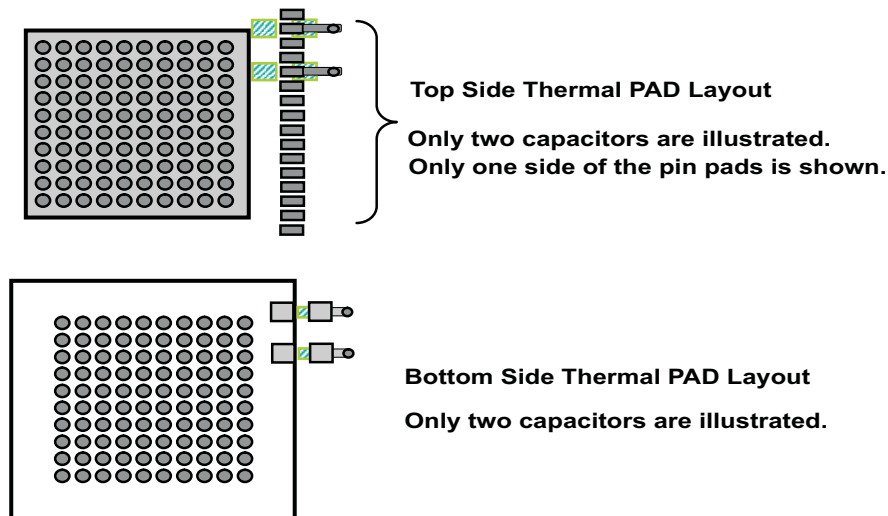

Figure 26. Device Layout

DEVICE POWER

The CDCE72010 is designed as a high performance device, therefore careful attention must be paid to device configuration with respect to power consumption. Total power consumption of the device can be estimated by adding up the total power consumed by each block in the device.

The Table below describes the blocks used and power consumed per block. The total power of the device can be calculated by multiplying the number of blocks used by the power consumption per block.

Table 16. Device Power

INTERNAL BLOCK POWER AT 3.3V (Typ)	POWER DISSIPATED / BLOCK	NUMBER OF BLOCKS / DEVICE
PLL Core and Input and Feedback Circuitries	530mW	1
Output Dividers	180mW	8
Output Buffers (LVPECL-HISWING) ⁽¹⁾	150mW	10
Output Buffers (LVDS-HISWING) ⁽¹⁾	75mW	10
Output Buffers (LVCMOS at 122 MHz) ⁽¹⁾	50mW	20

(1) Output buffers can be a total of 10 LVDS, 10 LVPECL, or 20 LVCMOS.

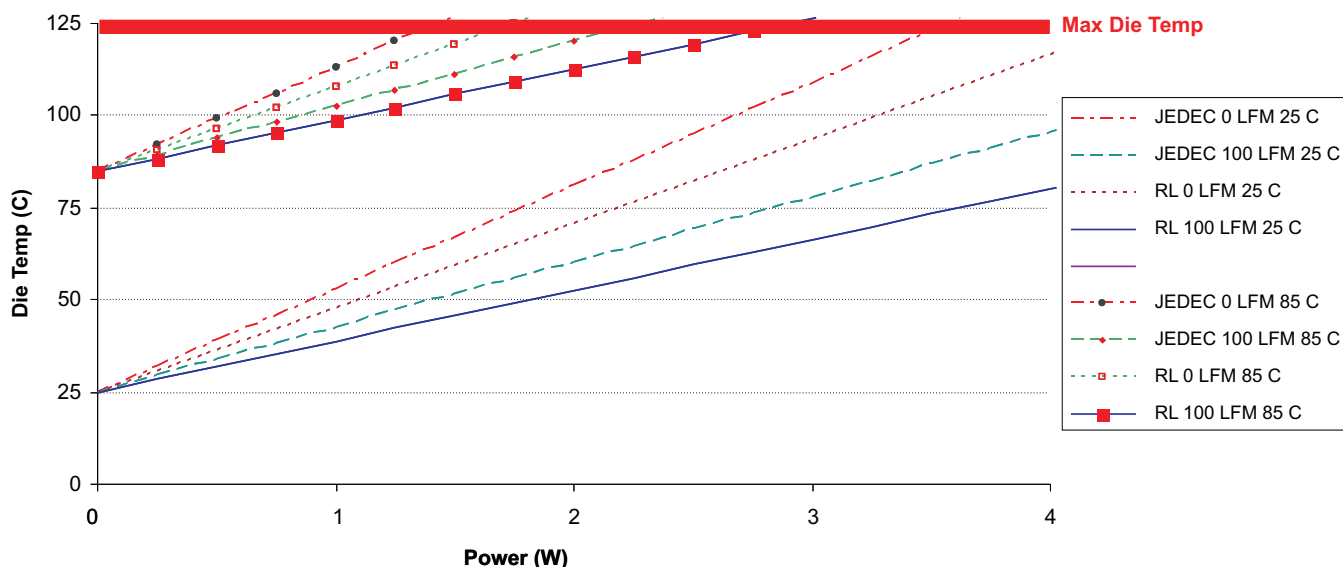

Figure 27. Die Temperature

LOOP FILTER

The CDCE72010 is designed to control an external Voltage Controlled Oscillator (VCO) or a Voltage Controlled Crystal Oscillator (VCXO) and to synchronize the controlled oscillators to the input reference. Controlling the Oscillator happens via a DC voltage that is applied to the Voltage control pin. This DC voltage is generated by the CDCE72010 in the form of AC pulses that get filtered by the external loop filter.

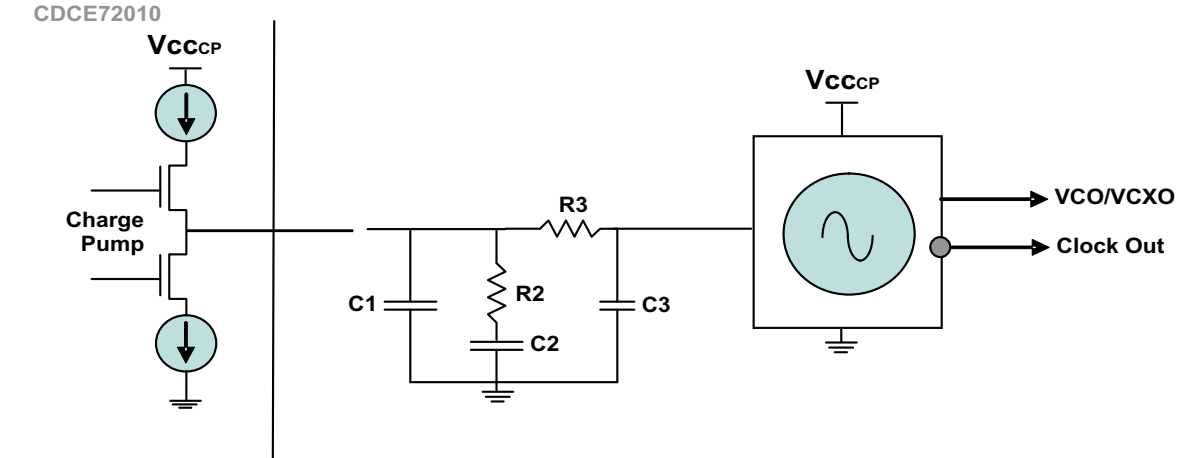

Figure 28. Loop Filter

UNIVERSAL OUTPUT BUFFERS

The CDCE72010 is designed to drive three types of clock signaling, LVPECL, LVDS, and LVCMOS from each of the ten outputs. This super buffer that contains all three drivers is referred to as the Universal Output Buffer. Only one driver can be enabled at one time. Each universal output buffer is made from four independent buffers in parallel. When LVPECL mode is selected, only the LVPECL Buffer is enabled and the rest of the buffers are 3-stated and in low power mode. When Selecting LVDS, only the LVDS Buffer is enabled and the rest of the buffers are 3-stated and in low power mode. When LVCMOS mode is selected, both LVCMOS drivers are enabled. One LVCMOS buffer drives the negative side and the other buffer drives the positive pin.

The LVCMOS drivers are driven from the same output divider but have separate control bits. In SPI Mode, bits 22, 23, 24, and 25 of Registers 0 to 9 are used to put the LVCMOS buffer in active, inverting, low, or 3-state. In CD Mode, those bits are used for different functions and the LVCMOS buffer can be active when selected or 3-state when their not.

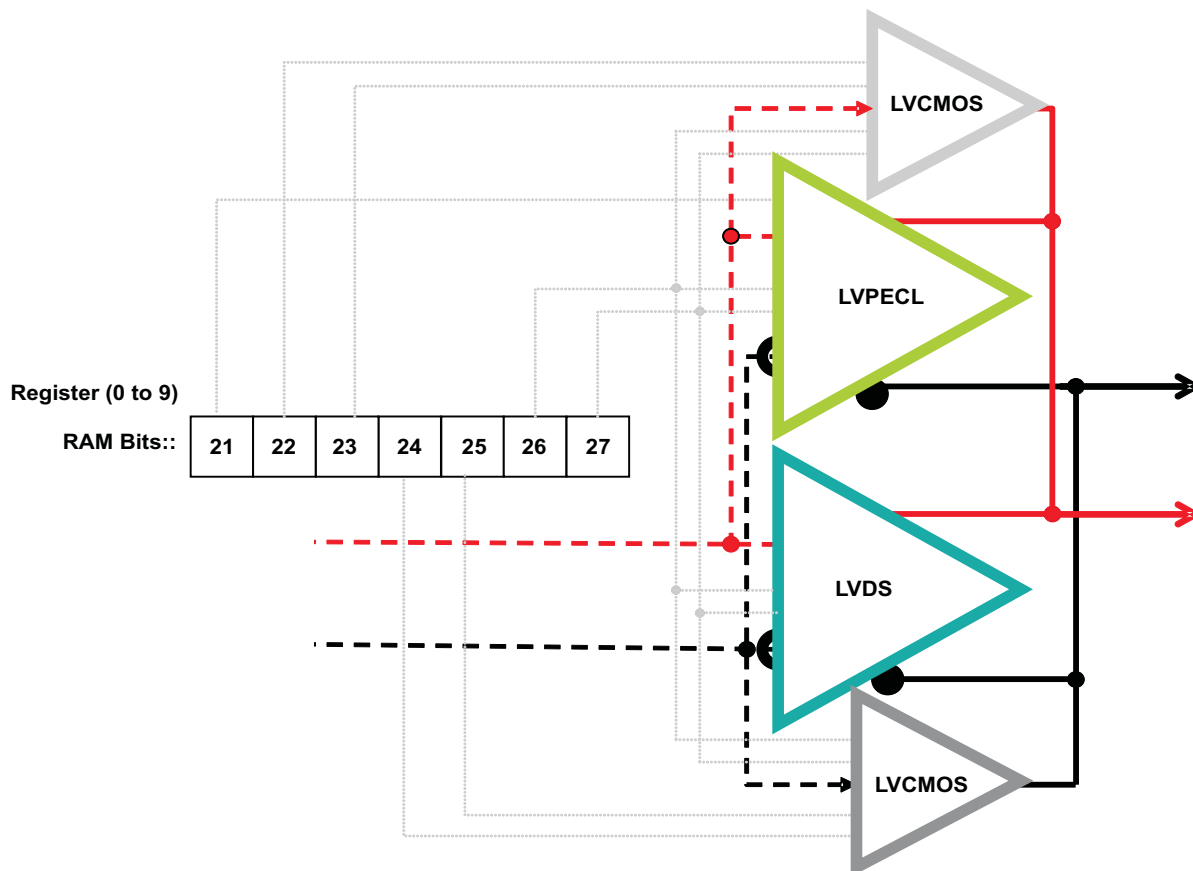

Figure 29. Universal Output Buffer

Output Dividers Synchronization

The CDCE72010 is a 10 output clock device with 8 output dividers and to insure that all the outputs are synchronous a synchronization startup circuitry is used. The synchronization circuitry generates a pulse to reset all the dividers in a way, that a predictable synchronous output is generated. The Synchronization signal can be generated from different sources and can be synchronized to a specific clock. The Block diagram below illustrates the signal path of the Output Divider Sync Signal. This function is assured up to 500 MHz.

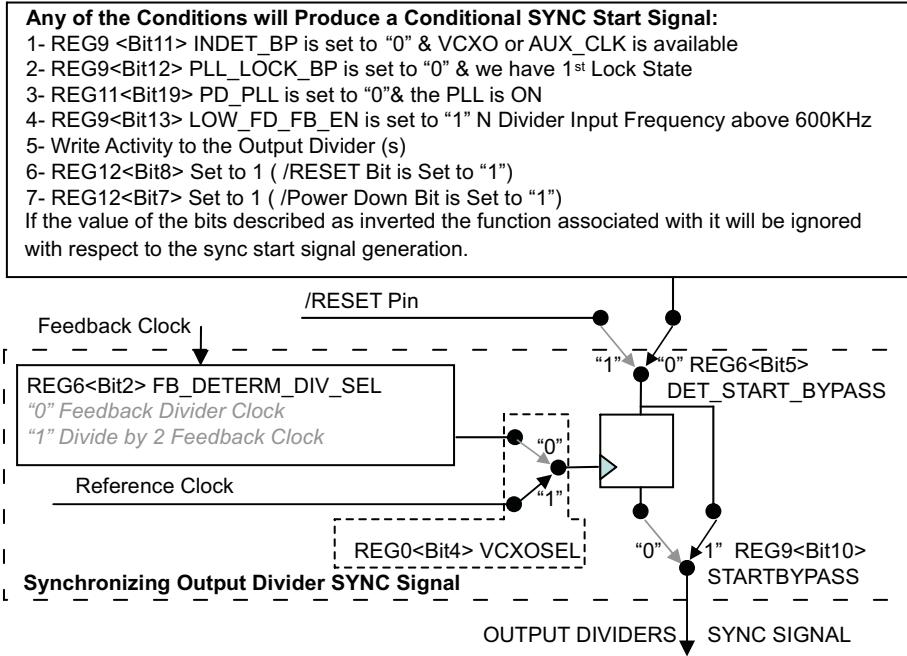

Figure 30. Output Divider Synchronization Block Diagram

POWER UP RESET, POWER DOWN MODE AND RESET OR HOLD

The CDCE72010 is designed to address various clock synchronization applications. Some functions can be set to be in automatic and manual mode or some functions can be controlled by software or by the internal circuitry.

Figure 31 below explains the various functionalities of power up reset internal circuitry functionality, power down functionality and reset functionality. The hold function shares the same block with Reset and one bit in the EEPROM will select either function.

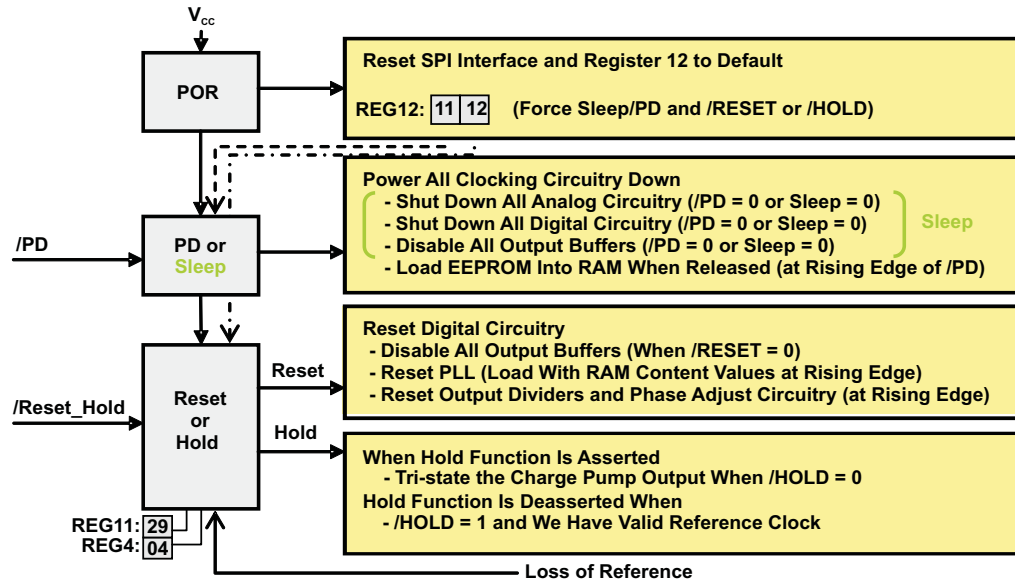

Figure 31. Powerup, Reset, and Powerdown Block Diagram

PACKAGING INFORMATION

Orderable Device	Status ⁽¹⁾	Package Type	Package Drawing	Pins	Package Qty	Eco Plan ⁽²⁾	Lead/Ball Finish	MSL Peak Temp ⁽³⁾
CDCE72010RGCR	ACTIVE	VQFN	RGC	64	2000	TBD	Call TI	Call TI
CDCE72010RGCT	ACTIVE	VQFN	RGC	64	250	TBD	Call TI	Call TI

⁽¹⁾ The marketing status values are defined as follows:

ACTIVE: Product device recommended for new designs.

LIFEBUY: TI has announced that the device will be discontinued, and a lifetime-buy period is in effect.

NRND: Not recommended for new designs. Device is in production to support existing customers, but TI does not recommend using this part in a new design.

PREVIEW: Device has been announced but is not in production. Samples may or may not be available.

OBsolete: TI has discontinued the production of the device.

⁽²⁾ Eco Plan - The planned eco-friendly classification: Pb-Free (RoHS), Pb-Free (RoHS Exempt), or Green (RoHS & no Sb/Br) - please check <http://www.ti.com/productcontent> for the latest availability information and additional product content details.

TBD: The Pb-Free/Green conversion plan has not been defined.

Pb-Free (RoHS): TI's terms "Lead-Free" or "Pb-Free" mean semiconductor products that are compatible with the current RoHS requirements for all 6 substances, including the requirement that lead not exceed 0.1% by weight in homogeneous materials. Where designed to be soldered at high temperatures, TI Pb-Free products are suitable for use in specified lead-free processes.

Pb-Free (RoHS Exempt): This component has a RoHS exemption for either 1) lead-based flip-chip solder bumps used between the die and package, or 2) lead-based die adhesive used between the die and leadframe. The component is otherwise considered Pb-Free (RoHS compatible) as defined above.

Green (RoHS & no Sb/Br): TI defines "Green" to mean Pb-Free (RoHS compatible), and free of Bromine (Br) and Antimony (Sb) based flame retardants (Br or Sb do not exceed 0.1% by weight in homogeneous material)

⁽³⁾ MSL, Peak Temp. -- The Moisture Sensitivity Level rating according to the JEDEC industry standard classifications, and peak solder temperature.

Important Information and Disclaimer:The information provided on this page represents TI's knowledge and belief as of the date that it is provided. TI bases its knowledge and belief on information provided by third parties, and makes no representation or warranty as to the accuracy of such information. Efforts are underway to better integrate information from third parties. TI has taken and continues to take reasonable steps to provide representative and accurate information but may not have conducted destructive testing or chemical analysis on incoming materials and chemicals. TI and TI suppliers consider certain information to be proprietary, and thus CAS numbers and other limited information may not be available for release.

In no event shall TI's liability arising out of such information exceed the total purchase price of the TI part(s) at issue in this document sold by TI to Customer on an annual basis.

RGC (S-PQFP-N64) CUSTOM DEVICE PLASTIC QUAD FLATPACK

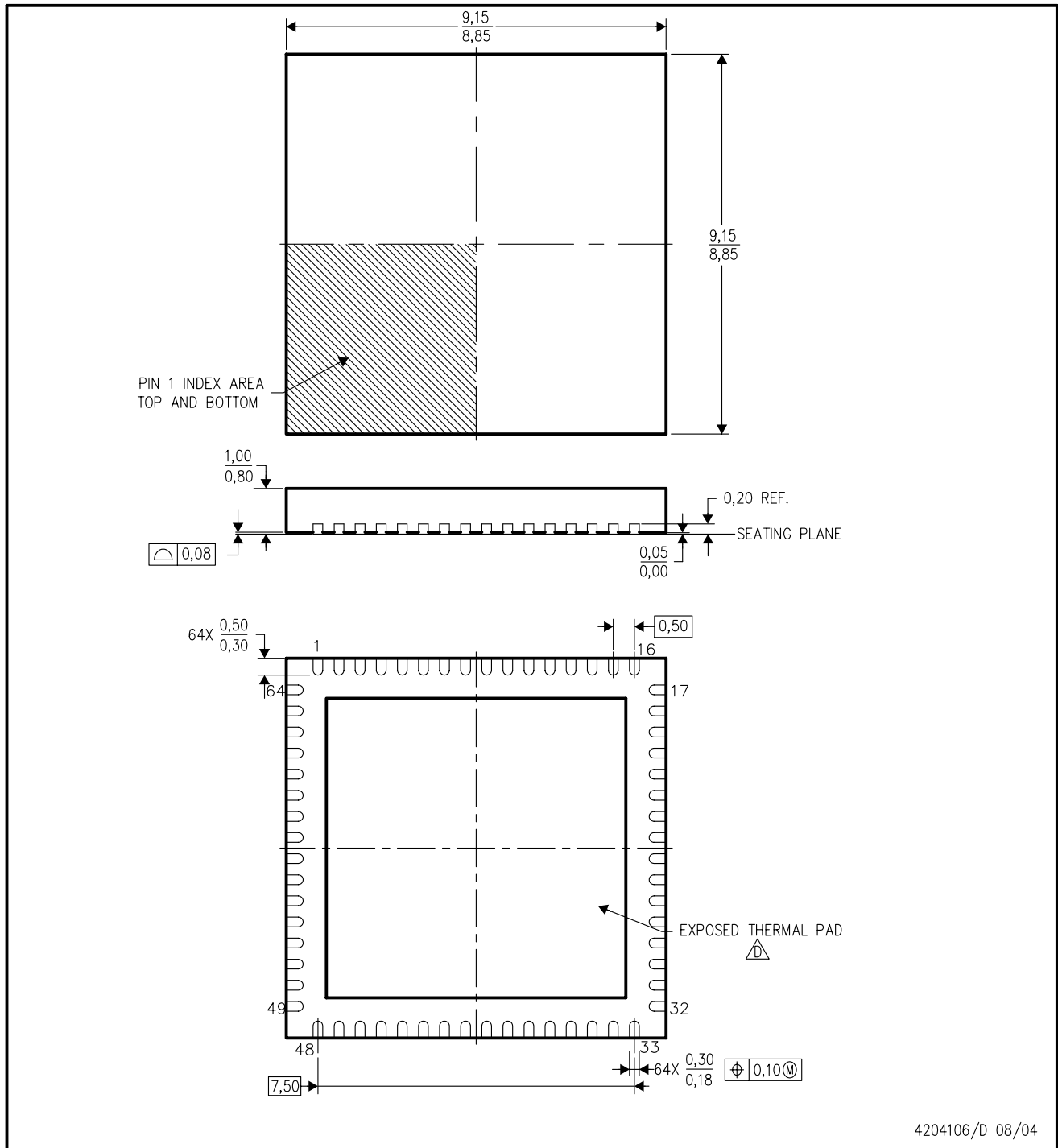

- NOTES:
- A. All linear dimensions are in millimeters. Dimensioning and tolerancing per ASME Y14.5-1994.
 - B. This drawing is subject to change without notice.
 - C. Quad Flatpack, No-leads (QFN) package configuration .
-  The package thermal pad must be soldered to the board for thermal and mechanical performance. See the Product Data Sheet for details regarding the exposed thermal pad dimensions.

THERMAL INFORMATION

This package incorporates an exposed thermal pad that is designed to be attached directly to an external heatsink. The thermal pad must be soldered directly to the printed circuit board (PCB). After soldering, the PCB can be used as a heatsink. In addition, through the use of thermal vias, the thermal pad can be attached directly to the appropriate copper plane shown in the electrical schematic for the device, or alternatively, can be attached to a special heatsink structure designed into the PCB. This design optimizes the heat transfer from the integrated circuit (IC).

For information on the Quad Flatpack No-Lead (QFN) package and its advantages, refer to Application Report, Quad Flatpack No-Lead Logic Packages, Texas Instruments Literature No. SCBA017. This document is available at www.ti.com.

The exposed thermal pad dimensions for this package are shown in the following illustration.

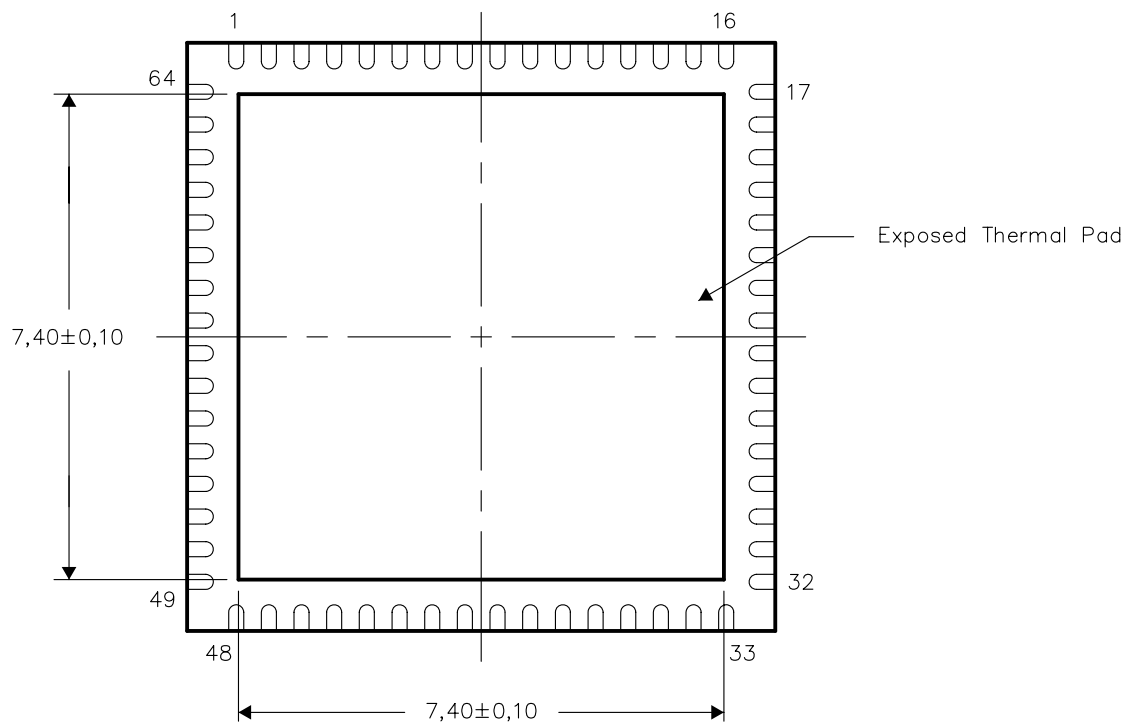

Bottom View

NOTE: All linear dimensions are in millimeters

Exposed Thermal Pad Dimensions

RGC (S-PQFP-N64)

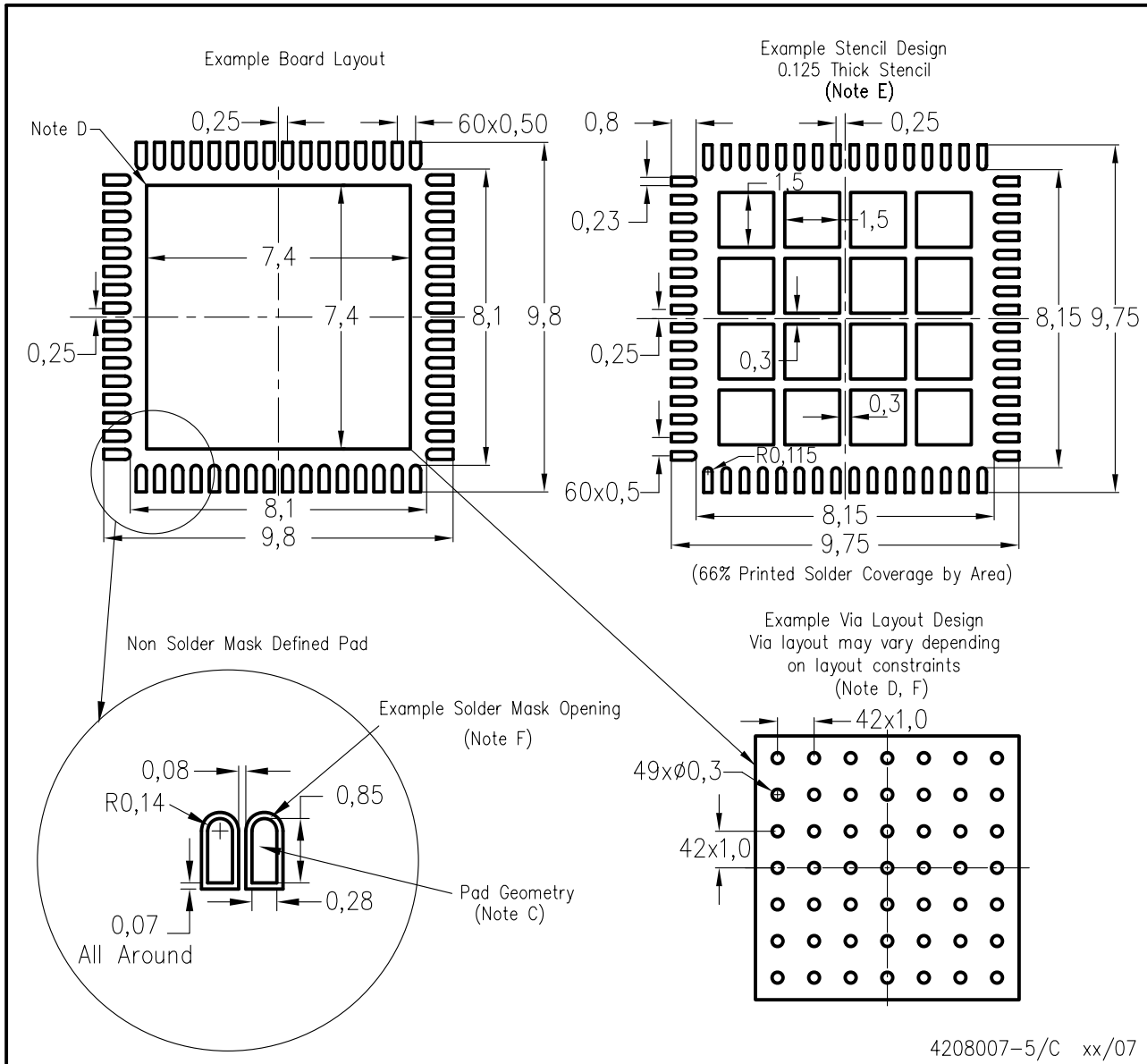

- NOTES:
- All linear dimensions are in millimeters.
 - This drawing is subject to change without notice.
 - Publication IPC-7351 is recommended for alternate designs.
 - This package is designed to be soldered to a thermal pad on the board. Refer to Application Note, Quad Flat-Pack Packages, Texas Instruments Literature No. SCBA017, SLUA271, and also the Product Data Sheets for specific thermal information, via requirements, and recommended board layout. These documents are available at www.ti.com <<http://www.ti.com>>.
 - Laser cutting apertures with trapezoidal walls and also rounding corners will offer better paste release. Customers should contact their board assembly site for stencil design recommendations. Refer to IPC 7525 for stencil design considerations.
 - Customers should contact their board fabrication site for recommended solder mask tolerances and via tenting recommendations for vias placed in thermal pad.

IMPORTANT NOTICE

Texas Instruments Incorporated and its subsidiaries (TI) reserve the right to make corrections, modifications, enhancements, improvements, and other changes to its products and services at any time and to discontinue any product or service without notice. Customers should obtain the latest relevant information before placing orders and should verify that such information is current and complete. All products are sold subject to TI's terms and conditions of sale supplied at the time of order acknowledgment.

TI warrants performance of its hardware products to the specifications applicable at the time of sale in accordance with TI's standard warranty. Testing and other quality control techniques are used to the extent TI deems necessary to support this warranty. Except where mandated by government requirements, testing of all parameters of each product is not necessarily performed.

TI assumes no liability for applications assistance or customer product design. Customers are responsible for their products and applications using TI components. To minimize the risks associated with customer products and applications, customers should provide adequate design and operating safeguards.

TI does not warrant or represent that any license, either express or implied, is granted under any TI patent right, copyright, mask work right, or other TI intellectual property right relating to any combination, machine, or process in which TI products or services are used. Information published by TI regarding third-party products or services does not constitute a license from TI to use such products or services or a warranty or endorsement thereof. Use of such information may require a license from a third party under the patents or other intellectual property of the third party, or a license from TI under the patents or other intellectual property of TI.

Reproduction of TI information in TI data books or data sheets is permissible only if reproduction is without alteration and is accompanied by all associated warranties, conditions, limitations, and notices. Reproduction of this information with alteration is an unfair and deceptive business practice. TI is not responsible or liable for such altered documentation. Information of third parties may be subject to additional restrictions.

Resale of TI products or services with statements different from or beyond the parameters stated by TI for that product or service voids all express and any implied warranties for the associated TI product or service and is an unfair and deceptive business practice. TI is not responsible or liable for any such statements.

TI products are not authorized for use in safety-critical applications (such as life support) where a failure of the TI product would reasonably be expected to cause severe personal injury or death, unless officers of the parties have executed an agreement specifically governing such use. Buyers represent that they have all necessary expertise in the safety and regulatory ramifications of their applications, and acknowledge and agree that they are solely responsible for all legal, regulatory and safety-related requirements concerning their products and any use of TI products in such safety-critical applications, notwithstanding any applications-related information or support that may be provided by TI. Further, Buyers must fully indemnify TI and its representatives against any damages arising out of the use of TI products in such safety-critical applications.

TI products are neither designed nor intended for use in military/aerospace applications or environments unless the TI products are specifically designated by TI as military-grade or "enhanced plastic." Only products designated by TI as military-grade meet military specifications. Buyers acknowledge and agree that any such use of TI products which TI has not designated as military-grade is solely at the Buyer's risk, and that they are solely responsible for compliance with all legal and regulatory requirements in connection with such use.

TI products are neither designed nor intended for use in automotive applications or environments unless the specific TI products are designated by TI as compliant with ISO/TS 16949 requirements. Buyers acknowledge and agree that, if they use any non-designated products in automotive applications, TI will not be responsible for any failure to meet such requirements.

Following are URLs where you can obtain information on other Texas Instruments products and application solutions:

Products

Amplifiers	amplifier.ti.com
Data Converters	dataconverter.ti.com
DSP	dsp.ti.com
Clocks and Timers	www.ti.com/clocks
Interface	interface.ti.com
Logic	logic.ti.com
Power Mgmt	power.ti.com
Microcontrollers	microcontroller.ti.com
RFID	www.ti-rfid.com
RF/IF and ZigBee® Solutions	www.ti.com/lprf

Applications

Audio	www.ti.com/audio
Automotive	www.ti.com/automotive
Broadband	www.ti.com/broadband
Digital Control	www.ti.com/digitalcontrol
Medical	www.ti.com/medical
Military	www.ti.com/military
Optical Networking	www.ti.com/opticalnetwork
Security	www.ti.com/security
Telephony	www.ti.com/telephony
Video & Imaging	www.ti.com/video
Wireless	www.ti.com/wireless

Mailing Address: Texas Instruments, Post Office Box 655303, Dallas, Texas 75265
Copyright © 2008, Texas Instruments Incorporated