

FLASH MEMORY

CMOS

64M (8M × 8) BIT NAND-type

MBM30LV0064

DESCRIPTION

The MBM30LV0064 device is a single 3.3 V 8M × 8 bit NAND flash memory organized as 528 byte × 16 pages × 1024 blocks. Each 528 byte page contains 16 bytes of optionally selected spare area which may be used to store ECC code (Specifications indicated are on condition that ECC system would be combined.). Program and read data is transferred between the memory array and page register in 528 byte increments. A 528 byte page can be programmed in 200 μs and an 8K byte block can be erased in 2 ms under typical conditions. An internal controller automates all program and erase operations including the verification of data margins. Data within a page can be read with a 50 ns cycle time per byte. The I/O pins are utilized for both address and data input/output as well as command inputs. The MBM30LV0064 is an ideal solution for applications requiring mass non-volatile storage such as solid state file storage, digital recording, image file memory for still cameras, and other uses which require high density and non-volatile storage.

PRODUCT LINE UP

Part No.		MBM30LV0064
Operating Temperature		-40°C to +85°C
Vcc		+2.7 V to +3.6 V
Power Dissipation (Max.)	Read	72 mW
	Erase / Program	72 mW
	TTL Standby	3.6 mW
	CMOS Standby	0.18 mW

PACKAGES

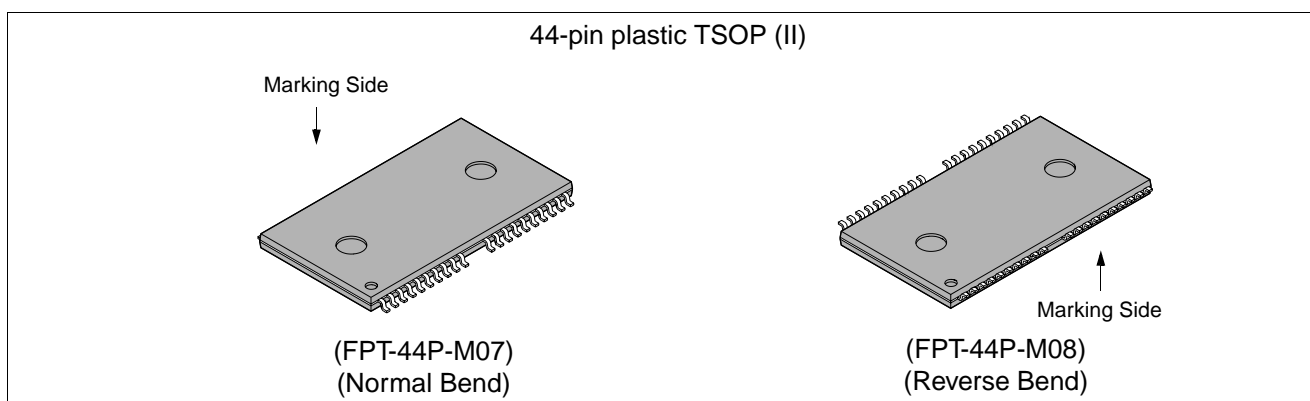

■ FEATURES

- **3.3 V-only operating voltage (2.7 V to 3.6 V)**
Minimizes system level power requirements
- **Organization**
Memory Cell Array : (8M + 256K) ×8 bit
Data Register : (512 + 16) ×8 bit
- **Automatic Program and Erase**
Page Program : (512 + 16) Byte
Block Erase : (8K + 256) Byte
- **528 Byte Page Read Operation**
Random Access : 7 μs (Max.)
Serial Access : 35 ns (Max.)
- **Fast Program and Erase**
Program Time : 200 μs (Typ.) / page
Block Erase Time : 2 ms (Typ.) / block
- **Command/Address/Data Multiplexed I/O Port**
- **Hardware Data Protection**
- **1,000,000 write/erase cycle guaranteed (ECC system required)**
- **Command Register Operation**
- **Package**
44(40)-pin TSOP Type II (0.8 mm pitch)
Normal/Reverse Type
- **Data Retention: 10 years**

■ PIN ASSIGNMENTS

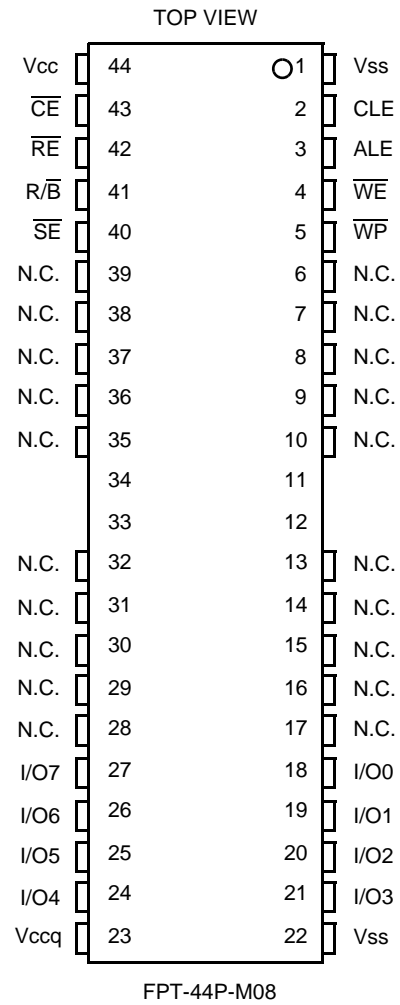
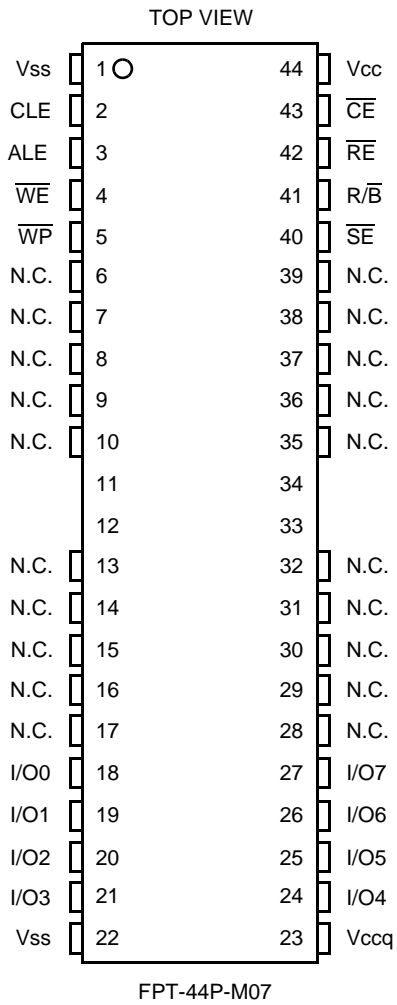

MBM30LV0064

■ PIN DESCRIPTIONS

Pin Number	Pin Name	Descriptions
18 to 21 24 to 27	I/O0 to I/O7	Data Input/Output The I/O ports are used for transferring command, address, and input/output data into and out of the device. The I/O pins will be high impedance when the outputs are disabled or the device is not selected.
2	CLE	Command Latch Enable The CLE signal enables the acquisition of the made command into the internal command register. When CLE="H", command are latched into the command register from the I/O port upon the rising edge of the \overline{WE} signal.
3	ALE	Address Latch Enable The ALE signal enables the acquisition of either address or data into the internal address/data register. The rising edge of \overline{WE} latch in addresses when ALE is high and data when ALE is low.
43	\overline{CE}	Chip Enable The \overline{CE} signal is used to select the device. When \overline{CE} is high, the device enters a low power standby mode. If \overline{CE} transitions high during a read operation, the standby mode will be entered. However, the \overline{CE} signal is ignored if the device is in a busy state ($R/\overline{B}=L$) during a program or erase operation.
42	\overline{RE}	Read Enable The \overline{RE} signal controls the serial data output. The falling edge of \overline{RE} drives the data onto the I/O bus and increments the column address counter by one.
4	\overline{WE}	Write Enable The \overline{WE} signal controls writes from the I/O port. Data, address, and commands on the I/O port are latched upon the rising of the \overline{WE} pulse.
5	\overline{WP}	Write Protect The \overline{WP} signal protects the device against accidental erasure or programming during power up/down by disabling the internal high voltage generators. \overline{WP} should be kept low when the device powers up until V_{CC} is above 2.5 V. During power down, \overline{WP} should be low when V_{CC} falls below 2.5 V.
40	\overline{SE}	Spare Area Enable The \overline{SE} input enables the spare area during sequential data input, page program, and Read 1.
41	R/\overline{B}	Ready Busy Output The R/\overline{B} output signal is used to indicate the operating status of the device. During program, erase, or read, R/\overline{B} is low and will return high upon the completion of the operation. The output buffer for this signal is an open drain.
23	V_{CCQ}	Output Buffer Power Supply The V_{CCQ} input supplies the power to the I/O interface logic. This power line is electrically isolated from V_{CC} for the purpose of supporting 5V tolerant I/O.
44	V_{CC}	Power Supply
1,22	V_{SS}	Ground
6 to 17 28 to 39	N.C.	No Connection

■ BLOCK DIAGRAM

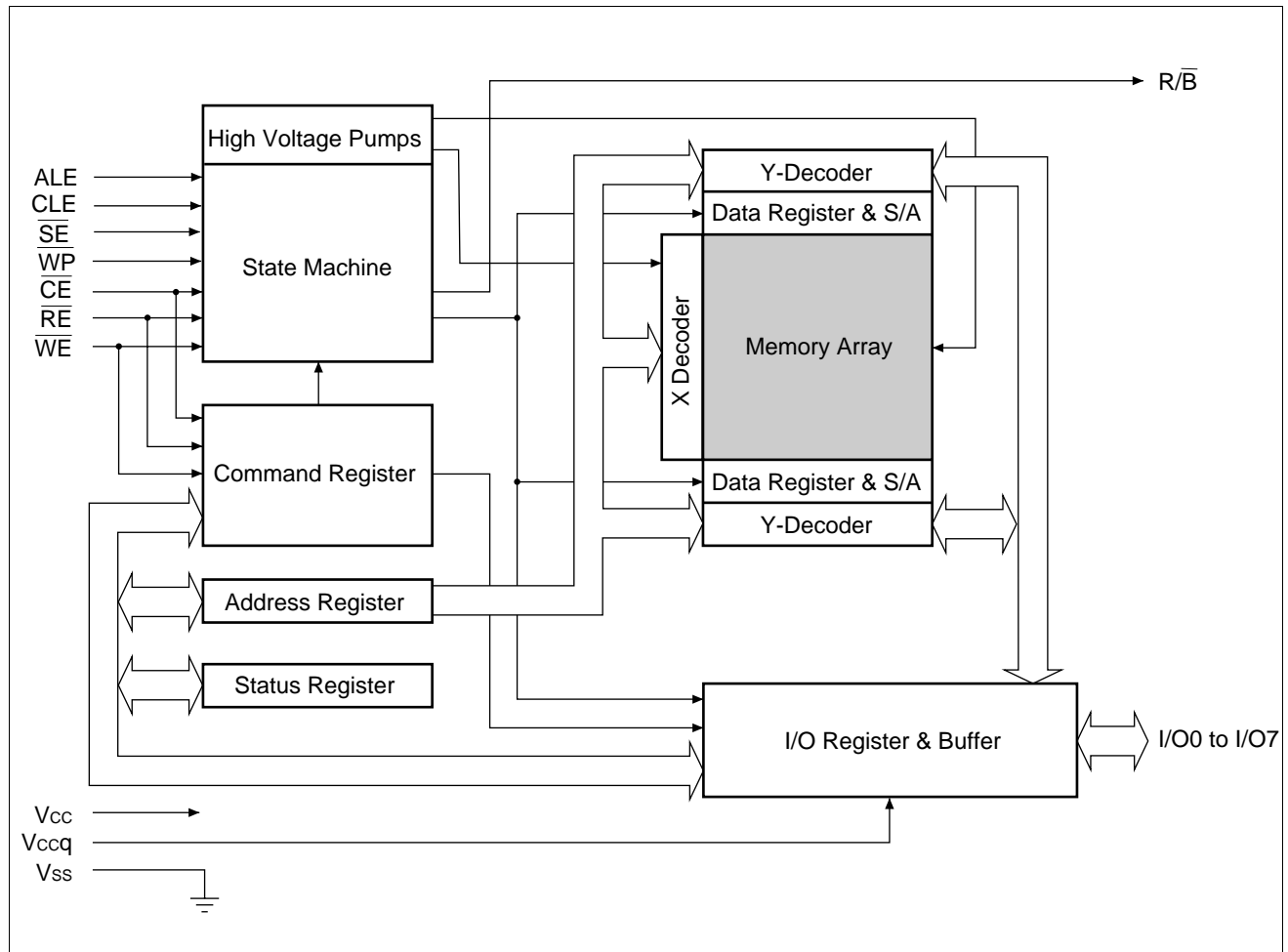

MBM30LV0064

■ SCHEMATIC CELL LAYOUT AND ADDRESS ASSIGNMENT

The Program operation is implemented in page units while the Erase operation is carried out in block units.

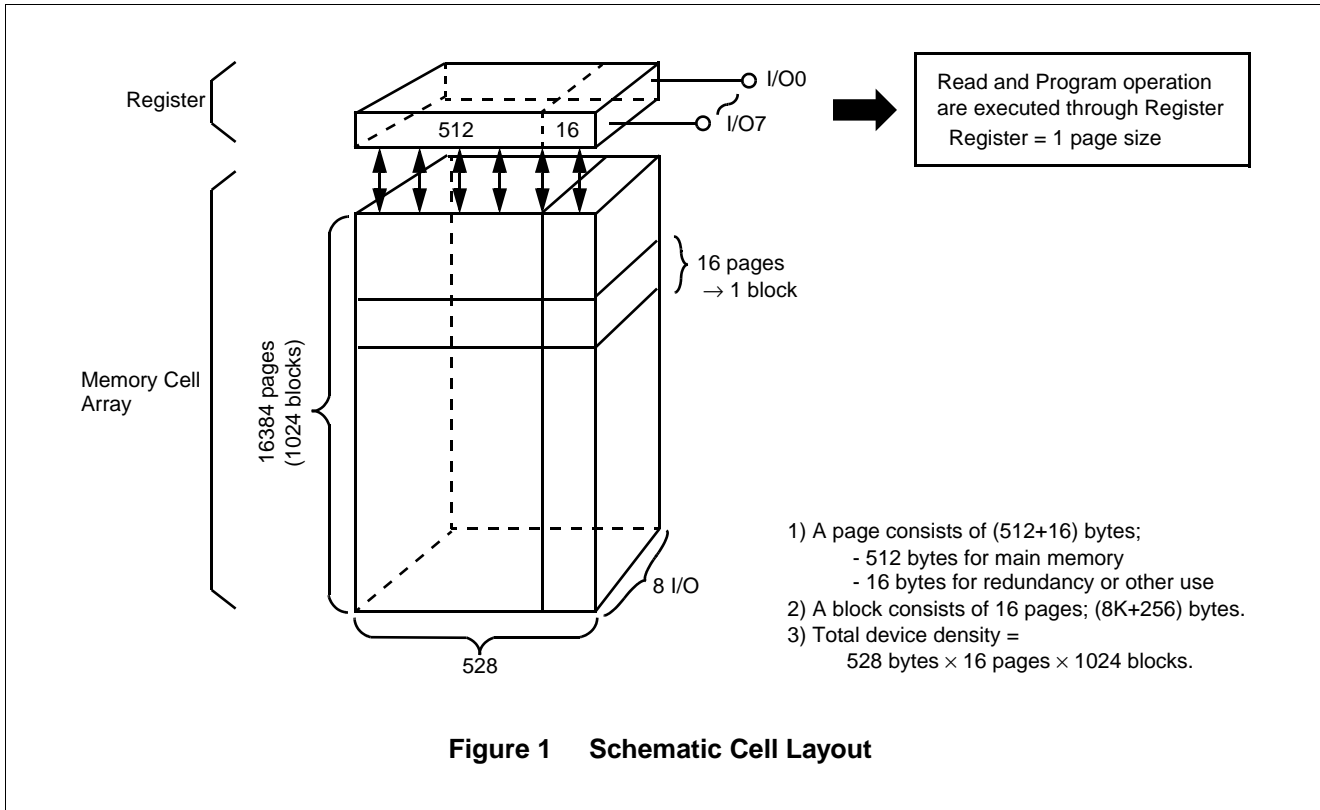

Table 1 Addressing

	I/O0	I/O1	I/O2	I/O3	I/O4	I/O5	I/O6	I/O7
First Cycle	A ₀	A ₁	A ₂	A ₃	A ₄	A ₅	A ₆	A ₇
Second Cycle	A ₉	A ₁₀	A ₁₁	A ₁₂	A ₁₃	A ₁₄	A ₁₅	A ₁₆
Third Cycle	A ₁₇	A ₁₈	A ₁₉	A ₂₀	A ₂₁	A ₂₂	X*	X*

A₀ to A₇ : column address

A₉ to A₂₂ : page address { A₁₃ to A₂₂ : block address
A₉ to A₁₂ : Page address in block

(A₈ is automatically set to "Low" or "High" by the "00h" command or the "01h" command in device inside.)

* : X = V_{IH} or V_{IL}

■ DEVICE BUS OPERATIONS

Table 2 Operation Table *1

Mode		CLE	ALE	\overline{CE}	\overline{WE}	\overline{RE}	\overline{SE}	\overline{WP}
Read Mode	Command Input	H	L	L		H	X*4	X
	Address Input (3 clock)	L	H	L		H	X*4	X
During Read (Busy)		L	L	L	H	H	L/H*3	X
Sequential Read & Data Output		L	L	L	H		L/H*3	X
Program/ Erase Mode	Command Input	H	L	L		H	X*4	H
	Address Input (2 or 3 clock)	L	H	L		H	X*4	H
Data Input		L	L	L		H	L/H*3	H
During Program (Busy)		X	X	X	X	X	L/H*3	H
During Erase (Busy)		X	X	X	X	X	X	H
Write Protect		X	X	X	X	X	X	L
Stand-by		X	X	H	X	X	0 V/V _{CC} *2	0 V/V _{CC} *2

*1: H: V_{IH}, L: V_{IL}, X: V_{IH} or V_{IL}

*2: \overline{WP} should be biased to CMOS high or CMOS low for standby.

*3: When \overline{SE} is high, spare area is deselected.

*4: If 50h command is input and read/program operation is executed only for spare area, \overline{SE} must be low at the command/address input.

Table 3 Read Mode Operation Status *

Operation	CLE	ALE	\overline{CE}	\overline{WE}	\overline{RE}	I/O0 to I/O7	Power Supply
Output Select	L	L	L	H	L	Data Output	Active
Output Deselect	L	L	L	H	H	High Impedance	Active
Standby	X	X	H	X	X	High Impedance	Standby

*: H: V_{IH}, L: V_{IL}, X: V_{IH} or V_{IL}

■ COMMAND OPERATION

Table 4 Command Table

Function	1st Cycle	2nd Cycle	Acceptable Command During Busy State
Read (1)	00h *1	—	
Read (2)	01h *2	—	
Read (3)	50h *3	—	
Sequential Data Input	80h	—	
Page Program	10h	—	
Block Erase	60h	D0h	
Reset	FFh	—	○
Status Read	70h	—	○
ID Read	90h	—	

*1: The 00h Command defines starting Address on the 1st half Page.

*2: The 01h Command defines starting Address on the 2nd half Page.

*3: The 50h Command is valid only When \overline{SE} is low level.

FUNCTIONAL DESCRIPTION

READ MODE

There are three distinct commands used for the read operation: 00h, 01h, and 50h. After the command cycle, three address cycles are used to input the starting address. Upon the rising edge of the final \overline{WE} pulse, there is a 7 μ s latency in which the 528 byte page is transferred to the data register. The R/\overline{B} signal may be used to monitor the completion of the data transfer. In the read operation, the \overline{CE} signal must stay "Low" after the third address input and during Busy state. If the \overline{CE} signal goes High during this period, the read operation will be terminated and then the standby mode will be entered. Once the page of data has been loaded into the data register, it may be clocked out with consecutive 50 ns \overline{RE} pulses. Each \overline{RE} pulse will automatically advance the column address by one. Once the last column has been read, the page address will automatically increment by one and the data register will be updated with the new page after 7 μ s.

The 00h Read command will set the pointer to the first half page of the array while the 01h Read command will set it in the second half. It may be logical to think of 00h as a command which sets $A_8 = 0$ while 01h sets $A_8 = 1$. The 50h command set the pointer to the spare area, consisting of columns 512 to 527. During this read mode, A_3 to A_0 is used to set the starting address of the spare area. As with the 00h and 01h operations, once the spare area page is loaded into the data register, it may be read out by \overline{RE} pulses. Each \overline{RE} pulse will increment the column address until the final column (527) is reached. At this time, the pointer will be reset to column 512 while the page address is incremented and the data register is updated. The 00h or 01h command is required to move the pointer back into the main array area.

Read (1), (2): 00h/01h

The Read (1), (2) mode is invoked by latching the 00h or 01h command into the command register. This mode (00h) will be automatically selected when the device powers up.

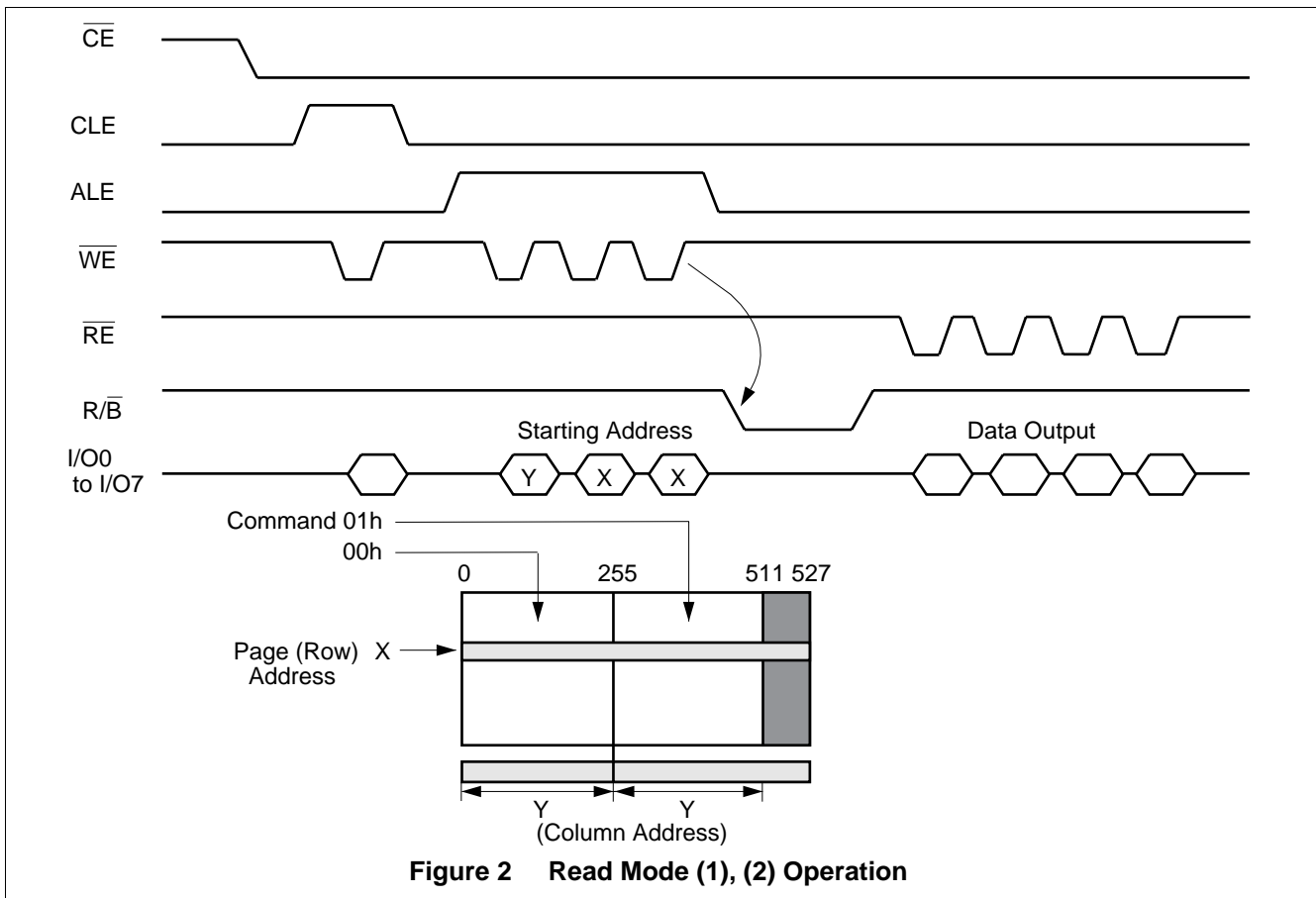

Read (3): 50h

The Read (3) mode has identical timing to that of Read (1) and (2). However, while Read (1) and (2) are used to access the array, Read (3) is used to access the 16 byte spare area. When the 50h command is executed, the pointer will be set to an address space between columns 512 and 527. The values of Y will complete the address decoding. During this operation, only address bits A₃ to A₀ are used to determine the starting column address; A₇ to A₄ are ignored. A₂₂ to A₉ are used to determine the starting row address.

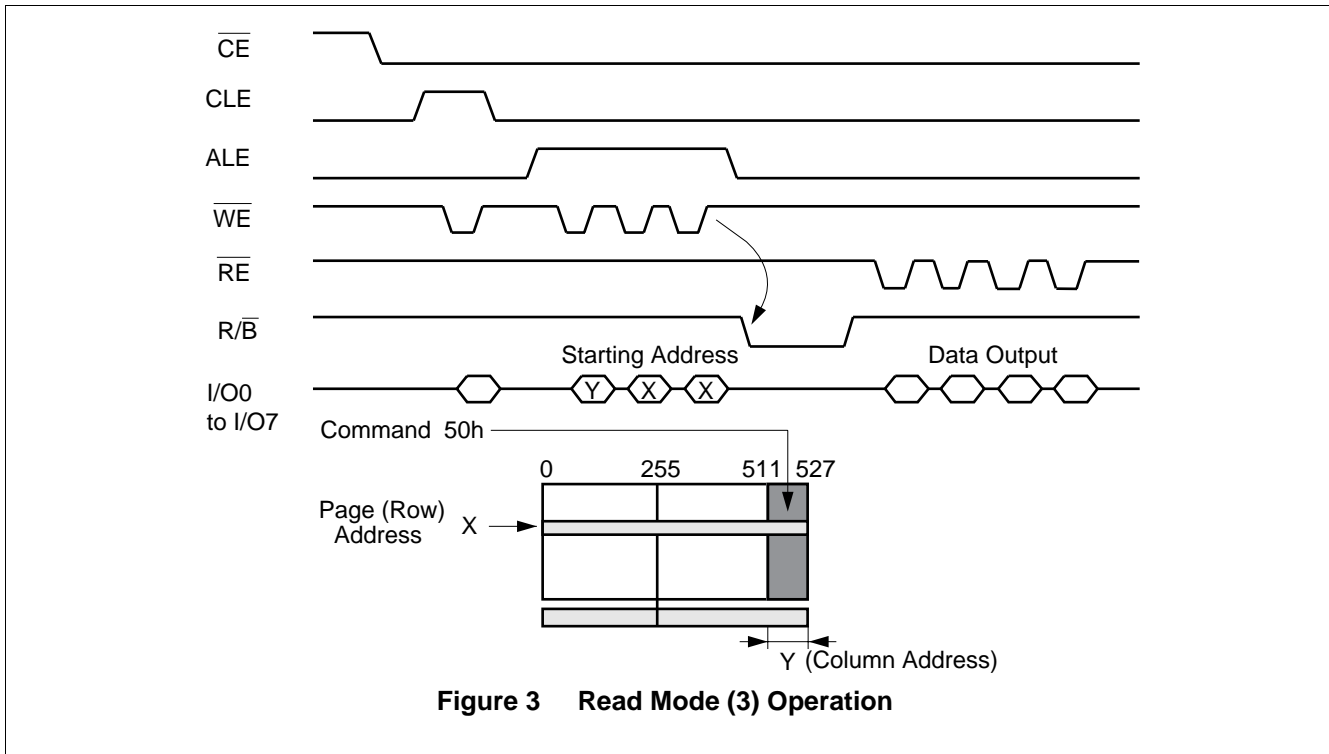

Sequential Read

Each \overline{RE} pulse used to output data from the data register will cause the column address pointer to increment by one. When the final column has been reached, the next page will be automatically loaded into the data register. The $\overline{R/B}$ signal may be used to monitor the completion of the data transfer.

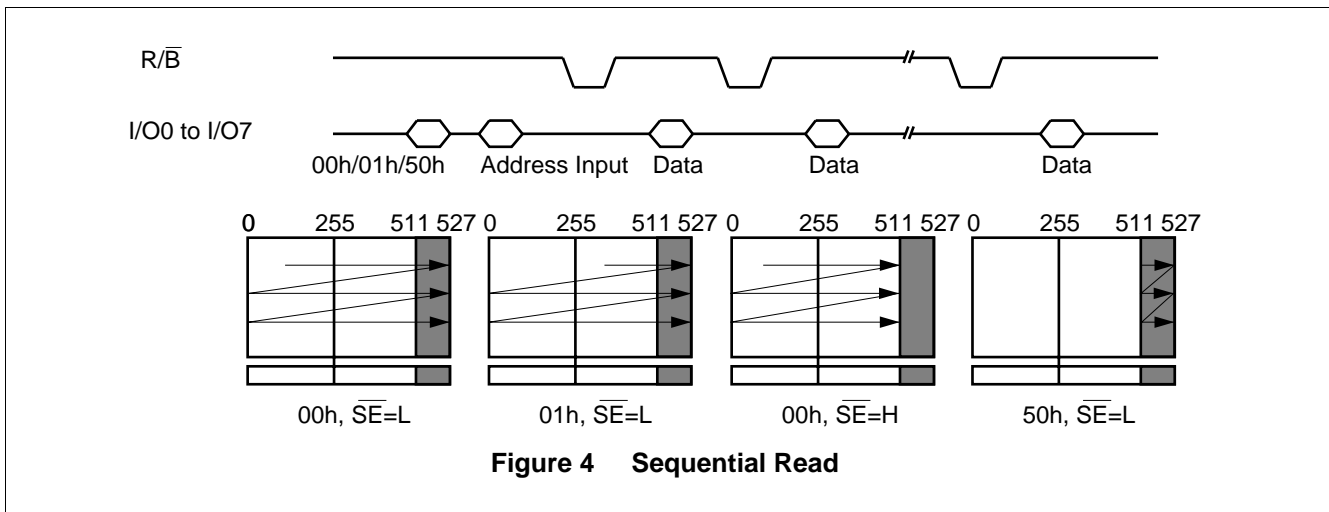

Page Program: 80h, 10h

The device is programmed either by the page or partial page. Programming is done by issuing the 80h command followed by three address cycles then serial data input. The 80h command may be preceded by either 00h, 01h or 50h to set the pointer to either the first half page, second half page, or spare area respectively. If the pointer command is not specifically issued, its location is determined by its previous use (see Application Note (2)). After the serial data input, any column address which did not receive new data will not be programmed. This enables a page to be partially programmed. After the data has been entered, the 10h command will initiate the embedded programming process. If the 10h command is issued without loading any new data, programming will not be initiated. A given page may not be partially programmed more than ten consecutive times without an intervening erase operation. During the programming cycle, the R/\bar{B} pin or Status Register bit I/O6 may be used to monitor the completion of the programming cycle. Only the Reset and Read Status commands are valid while programming is in progress. After programming, the Status Register bit I/O0 should be checked to verify whether the procedure was successful or not.

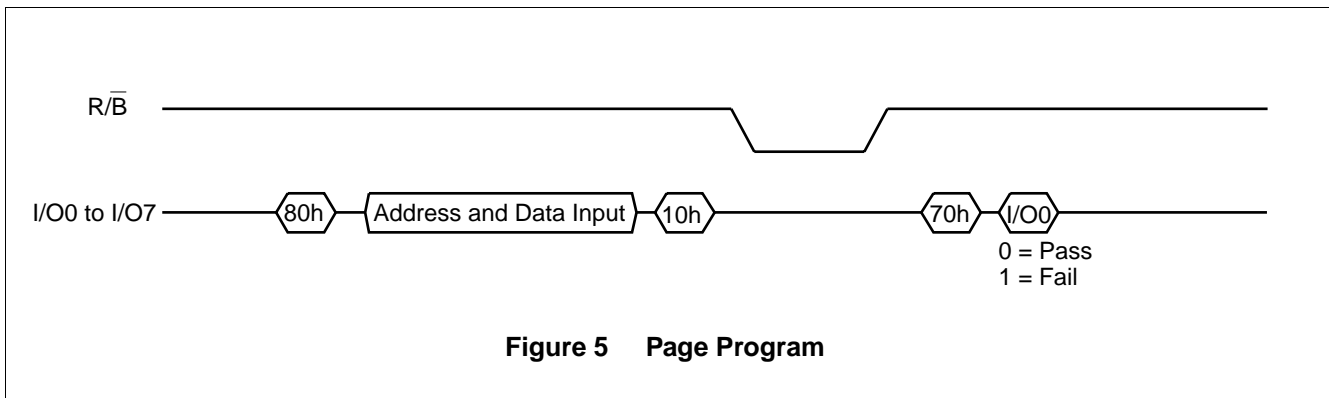

Block Erase: 60h

The device data is erased in a block consisting of sixteen pages. The erase operation begins with the 60h command followed by two address cycles in which the block to be erased is entered. While the two address cycles require A_{22} to A_9 to be entered, A_{12} to A_9 are don't care bits. Once the block address is successfully loaded, the D0h command is entered to initiate the erase operation. The R/\bar{B} signal may be used to monitor the completion of the cycle. Upon completion, the Status Register bit I/O0 should be used to verify a successful erase.

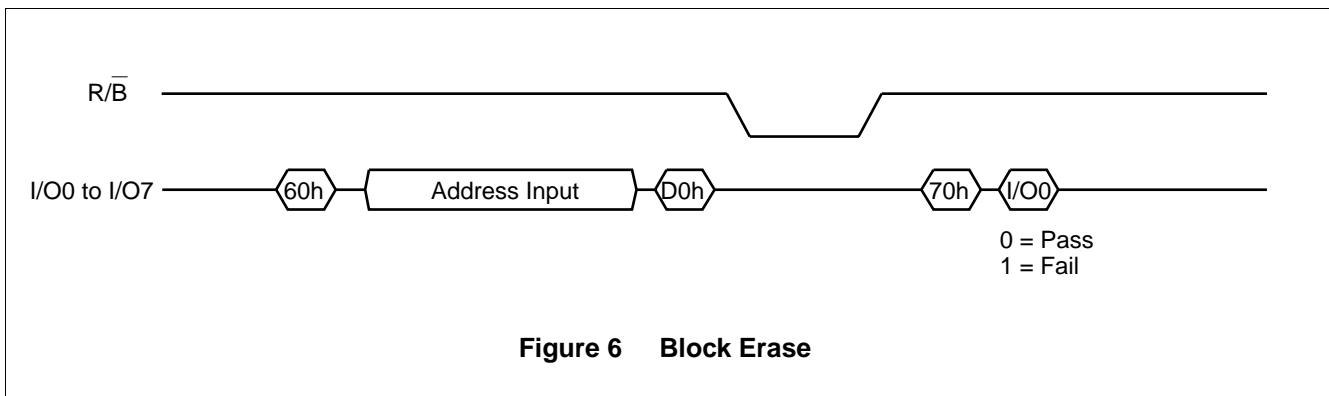

MBM30LV0064

Read ID: 90h

This mode allows the identification of the manufacturer and product. After the 90h command cycle, one address cycle follows in which 00h is entered. The next two \overline{RE} pulses will output the manufacturer and device code respectively.

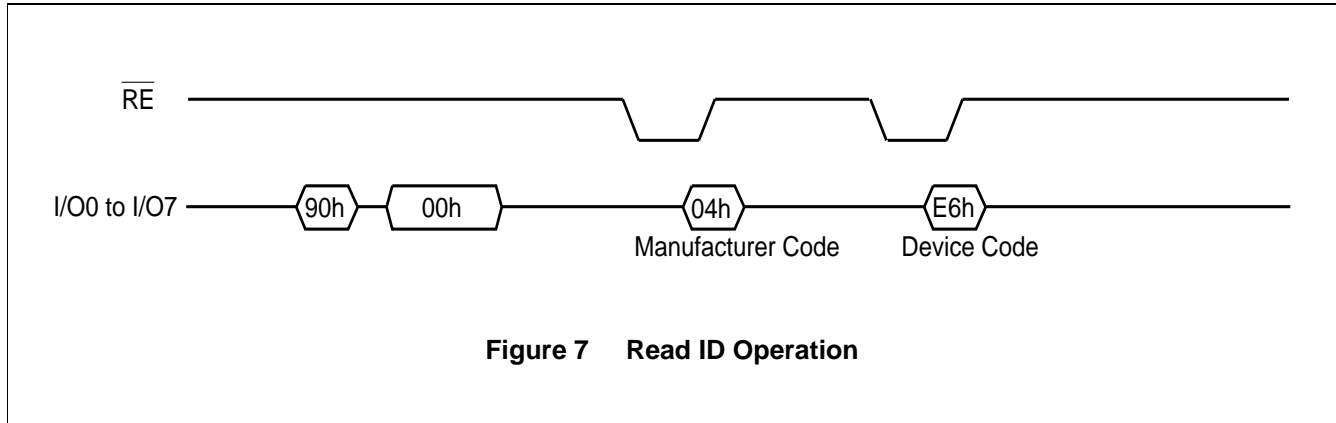

Table 5 Code Table

	I/O7	I/O6	I/O5	I/O4	I/O3	I/O2	I/O 1	I/O0	Code
Manufacturer	0	0	0	0	0	1	0	0	04h
Device	1	1	1	0	0	1	1	0	E6h

Status Read: 70h

The Status Register may be used to determine if the device is ready, in the write protect mode, or passed program/erase operations. After the 70h command is entered, the more recent falling edge of either \overline{CE} or \overline{RE} will output the contents of the status register to I/O0 to 7. The status register is continually updated and does not require either \overline{CE} or \overline{RE} to be toggled. By utilizing the \overline{CE} pin, multiple devices with R/B pins wired together may be polled to determine their specific status.

Table 6 Status Output Table

	Status	Description
I/O0	Program/Erase	0 = Pass; 1 = Fail
I/O1	Not Used	
I/O2	Not Used	
I/O3	Not Used	
I/O4	Not Used	
I/O5	Not Used	
I/O6	Ready/Busy	0 = Busy; 1 = Ready
I/O7	Write Protect	0 = Protected; 1 = Unprotected

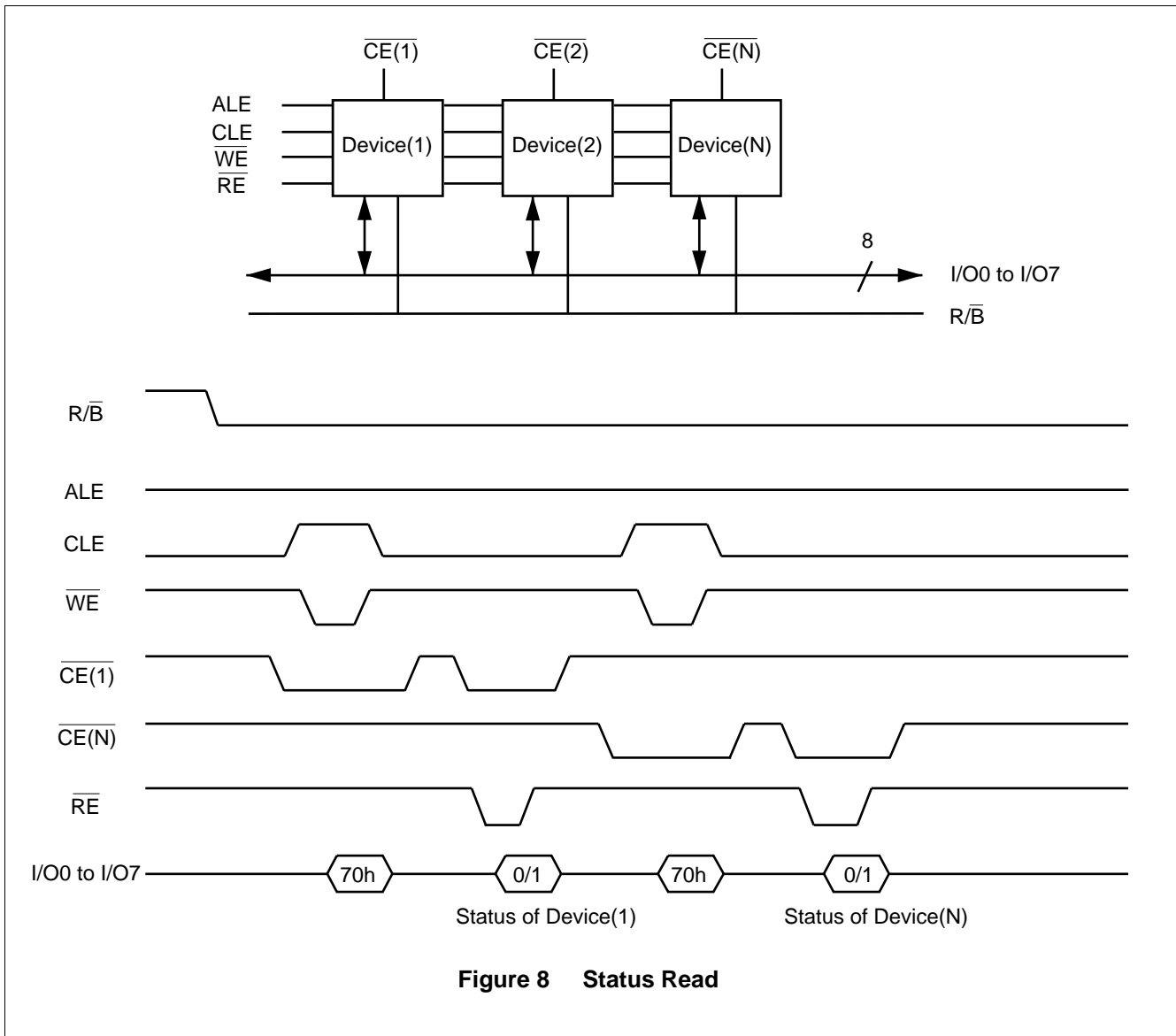

Reset

When the device is busy during program, erase, or read, it can be reset by entering the command FFh. If $\overline{WP} = 1$, the Status Register will be set to C0h. If a reset command is issued while the device is in the reset state, the command will be ignored. If the device is reset during the program or erase operations, the internal high voltages will be discharged before $\overline{R/B}$ goes high.

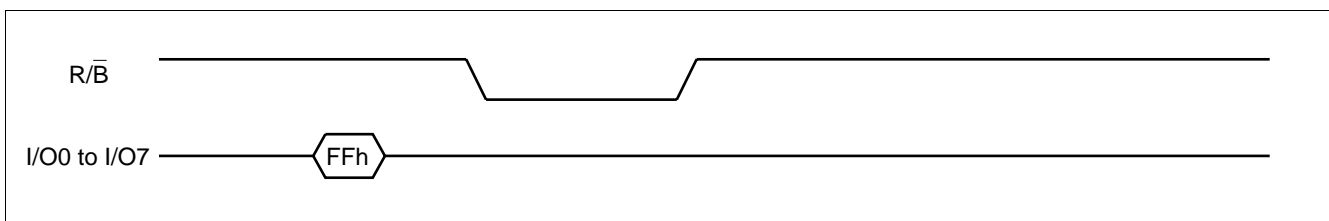

MBM30LV0064

■ ABSOLUTE MAXIMUM RATINGS

Parameter	Symbol	Rating		Unit
		Min.	Max.	
Ambient Temperature with Power Applied	T_A	-40	+85	°C
Storage Temperature	T_{stg}	-55	+125	°C
Voltage on a I/O pin with Respect to Ground *	V_{IO}	-0.6	$V_{CCQ} + 0.5$	V
Voltage on a pin Except I/O with Respect to Ground *	V_{IN}	-0.6	$V_{CC} + 0.5$	V
Power Supply Voltage	V_{CC}	-0.6	+5.5	V
	V_{CCQ}	-0.6	+6.0	

*: Minimum DC voltage on input or I/O pins is -0.5V. During voltage transitions, inputs may under shoot V_{SS} to -2.0 V for periods of up to 20 ns. Maximum DC voltage on input pins is $V_{CC} + 0.5$ V and on I/O pins are $V_{CCQ} + 0.5$ V. During voltage transitions, input pins may overshoot to $V_{CC} + 2.0$ V for periods of up to 20 ns and I/O pins may overshoot to $V_{CCQ} + 2.0$ V for periods of up to 20 ns.

WARNING: Semiconductor devices can be permanently damaged by application of stress (voltage, current, temperature, etc.) in excess of absolute maximum ratings. Do not exceed these ratings.

■ RECOMMENDED OPERATING CONDITIONS

Parameter	Symbol	Value		Unit
		Min.	Max.	
Supply Voltages	V_{CC}	+2.7	+3.6	V
Supply Voltages	V_{CCQ} *	+2.7	+5.5	V
Voltages	V_{SS}	0		V
Ambient Temperature	T_A	-40	+85	°C

*: $V_{CCQ} = 5.0$ V \pm 10% can be guaranteed on $V_{CC} \geq 3.0$ V.

Note: Operating ranges define those limits between which the functionality of the device is guaranteed.

WARNING: The recommended operating conditions are required in order to ensure the normal operation of the semiconductor device. All of the device's electrical characteristics are warranted when the device is operated within these ranges.

Always use semiconductor devices within their recommended operating condition ranges. Operation outside these ranges may adversely affect reliability and could result in device failure.

No warranty is made with respect to uses, operating conditions, or combinations not represented on the data sheet. Users considering application outside the listed conditions are advised to contact their FUJITSU representatives beforehand.

■ ELECTRICAL CHARACTERISTICS

1. DC Characteristics

Parameter	Symbol	Conditions	Value			Unit
			Min.	Typ.	Max.	
Sequential Read Current	I_{CC1}	$t_{CYCLE} = 50 \text{ ns}$, $\overline{CE} = V_{IL}$, $I_{OUT} = 0 \text{ mA}$	—	10	20	mA
Command Address Input Current	I_{CC3}	$t_{CYCLE} = 50 \text{ ns}$, $\overline{CE} = V_{IL}$	—	10	20	mA
Data Input Current	I_{CC4}	—	—	10	20	mA
Program Current	I_{CC6}	—	—	10	20	mA
Erase Current	I_{CC7}	—	—	10	20	mA
Stand-by Current (TTL)	I_{SB1}	$\overline{CE} = V_{IH}$, $\overline{WP} = \overline{SE} = 0 \text{ V}/V_{CC}$	—	—	1	mA
Stand-by Current (CMOS)	I_{SB2}	$\overline{CE} = V_{CC} - 0.2 \text{ V}$, $\overline{WP} = \overline{SE} = 0 \text{ V}/V_{CC}$	—	10	50	μA
Input Leakage Current	I_{LI}	$V_{IN} = 0 \text{ to } 3.6 \text{ V}$	—	—	± 10	μA
Output Leakage Current	I_{LO}	$V_{OUT} = 0 \text{ to } 3.6 \text{ V}$	—	—	± 10	μA
Input High Voltage	V_{IH}	I/O pins	2.0	—	$V_{CCQ} + 0.3$	V
		Except I/O pins	2.0	—	$V_{CC} + 0.3$	V
Input Low Voltage	V_{IL}	—	-0.3	—	0.8	V
Output High Voltage Level	V_{OH}	$I_{OH} = -400 \mu\text{A}$	2.4	—	—	V
Output Low Voltage Level	V_{OL}	$I_{OL} = 2.1 \text{ mA}$	—	—	0.4	V
Output Low Current (R/ \overline{B})	I_{OL}	$V_{OL} = 0.4 \text{ V}$	8	10	—	mA

MBM30LV0064

2. AC Characteristics (Note 1)

Parameter	Symbol	Value		Unit
		Min.	Max.	
CLE Setup Time	t _{CLS}	0	—	ns
CLE Hold Time	t _{CLH}	10	—	ns
$\overline{\text{CE}}$ Setup Time	t _{CS}	0	—	ns
$\overline{\text{CE}}$ Hold Time	t _{CH}	10	—	ns
Write Pulse Width	t _{WP}	25	—	ns
ALE Setup Time	t _{ALS}	0	—	ns
ALE Hold Time	t _{ALH}	10	—	ns
Data Setup Time	t _{DS}	20	—	ns
Data Hold Time	t _{DH}	10	—	ns
Write Cycle Time	t _{WC}	50	—	ns
$\overline{\text{WE}}$ High Hold Time	t _{WH}	15	—	ns
$\overline{\text{WP}}$ High to $\overline{\text{WE}}$ Low	t _{WW}	100	—	ns
Ready to $\overline{\text{RE}}$ Falling Edge	t _{RR}	20	—	ns
Read Pulse Width	t _{RP}	30	—	ns
Read Cycle Time	t _{RC}	50	—	ns
$\overline{\text{RE}}$ Access Time (Serial Data Access)	t _{REA}	—	35	ns
$\overline{\text{CE}}$ High Time for the Last Address in Serial Read Cycle (Note 3)	t _{CEH}	100	—	ns
$\overline{\text{RE}}$ Access Time (ID Read)	t _{REAI} D	—	35	ns
$\overline{\text{RE}}$ High to Output High Impedance	t _{RHZ}	15	30	ns
$\overline{\text{CE}}$ High to Output High Impedance	t _{CHZ}	—	20	ns
$\overline{\text{RE}}$ High Hold Time	t _{REH}	15	—	ns
Output High Impedance to $\overline{\text{RE}}$ Falling Edge	t _{IR}	0	—	ns
$\overline{\text{RE}}$ Access Time (Status Read)	t _{RSTO}	—	35	ns
$\overline{\text{CE}}$ Access Time (Status Read)	t _{CS} TO	—	45	ns
$\overline{\text{WE}}$ High to $\overline{\text{RE}}$ Low	t _{WHR}	60	—	ns
ALE Low to $\overline{\text{RE}}$ Low (ID Read)	t _{AR1}	100	—	ns
$\overline{\text{CE}}$ Low to $\overline{\text{RE}}$ Low (ID Read)	t _{CR}	100	—	ns
Data Transfer from Memory Cell Array to Register	t _R	—	7	μs
$\overline{\text{WE}}$ High to Busy	t _{WB}	—	100	ns

(Continued)

(Continued)

Parameter	Symbol	Value		Unit
		Min.	Max.	
ALE Low to \overline{RE} Low (Read Cycle)	t_{AR2}	50	—	ns
\overline{RE} Last Clock Rising Edge to Busy (in Sequential Read)	t_{RB}	—	100	ns
\overline{CE} High to Ready (in Case of Interception by \overline{CE} in Read Mode) (Note 2)	t_{CRY}	—	50 + t_r (R/ \overline{B})	ns
Device Resetting Time (Read/Program/Erase)	t_{RST}	—	5/10/500	μ s

Notes: 1. AC Test Conditions:

Operating range	$V_{CC} = 2.7$ to 3.6 V	$V_{CC} = 3.0$ to 3.6 V
Input level	2.4 V/0.4 V	
Input comparison level	1.5 V/1.5 V	
Output data comparison level	1.5 V/1.5 V	
Output load	1TTL	
Load capacitance (C_L)	50 pF	100 pF
Transition time (t_r)	5 ns	

- The time to go from \overline{CE} high to Ready depends on the pull-up resistor of the R/ \overline{B} pin (see Application Notes (6)) toward the end of this document.
- In case that toggling \overline{CE} to high after access to the last address (address 527) in the register in the read mode (1), (2), and (3), the \overline{CE} high time must be held for 100 ns or more when the delay time of \overline{CE} with respect to \overline{RE} is 0 to 200 ns (see the figure below). When the \overline{CE} delay time is within 30 ns, the device is kept in the Ready state and will output no Busy signal.

MBM30LV0064

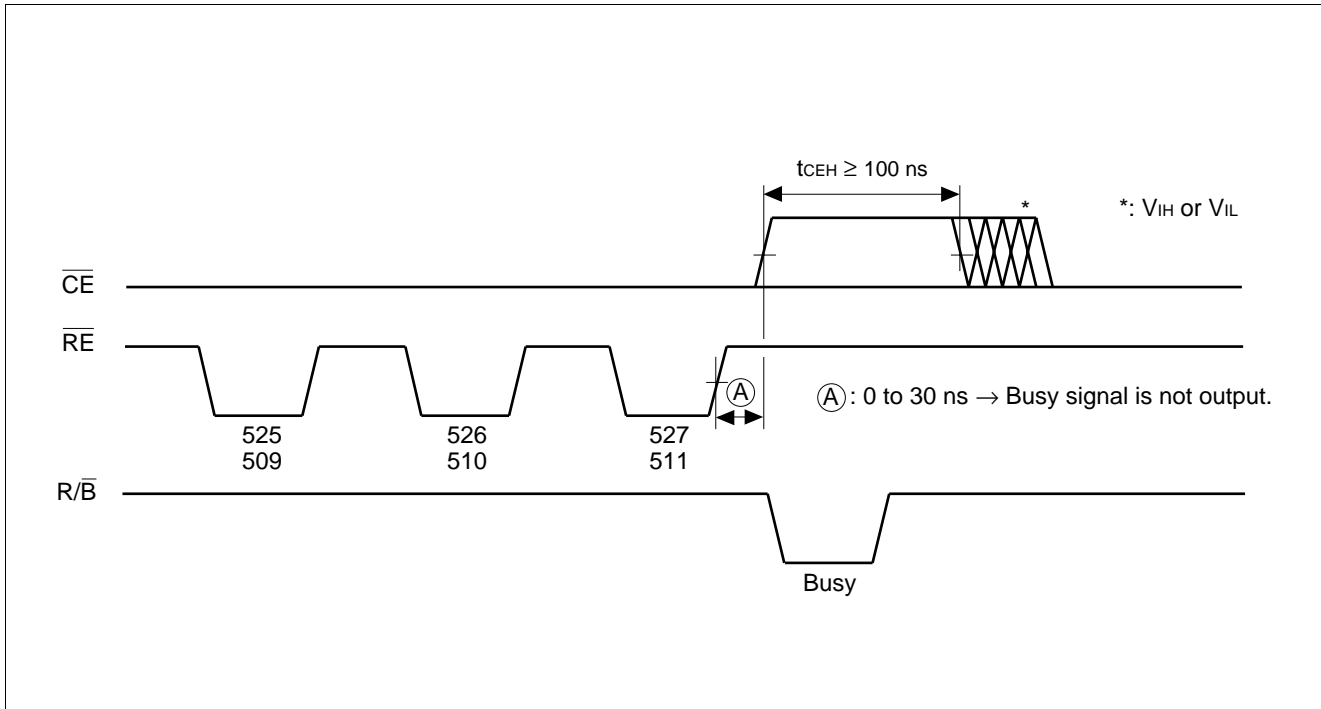

■ ERASE AND PROGRAMMING PERFORMANCE

Parameter	Symbol	Value			Unit	Remarks
		Min.	Typ.	Max.		
Average Programming Time	t _{PROG}	—	200	1000	μs	
Number of Programming Cycles on Same Page	N	—	—	10		*1
Block Erasing Time	t _{BERASE}	—	2	10	ms	
Number of Program/Erase Cycles	P/E	1 × 10 ⁶	—	—		*2

*1: Refer to Application Note (10) toward the end of this document.

*2: Refer to Application Note (13) toward the end of this document.

This specification is on conditions that ECC system would be combined.

■ VALID BLOCKS

The MBM30LV0064 occasionally contains unusable blocks. Refer to Application Note (12) toward the end of this document.

Parameter	Symbol	Value			Unit
		Min.	Typ.	Max.	
Valid Block Number	N _{VB}	1014	1020	1024	Block

■ PIN CAPACITANCE

Parameter	Symbol	Condition	Value		Unit
			Typ.	Max.	
Input Capacitance	C _{IN}	V _{IN} = 0	—	10	pF
Output Capacitance	C _{OUT}	V _{OUT} = 0	—	10	pF

Notes: 1. Test conditions T_A = 25°C, f = 1.0 MHz

2. Sampled, not 100% tested.

■ TIMING DIAGRAMS

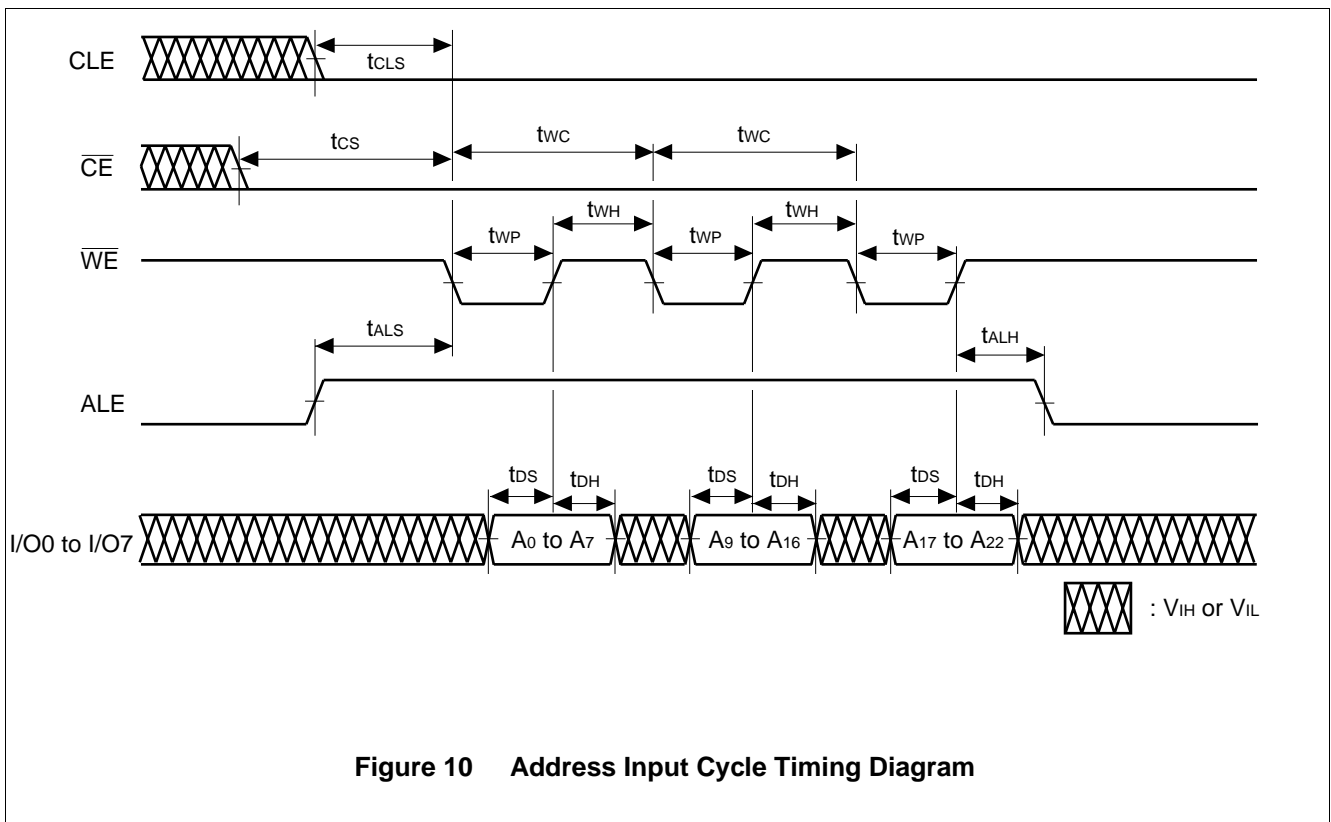
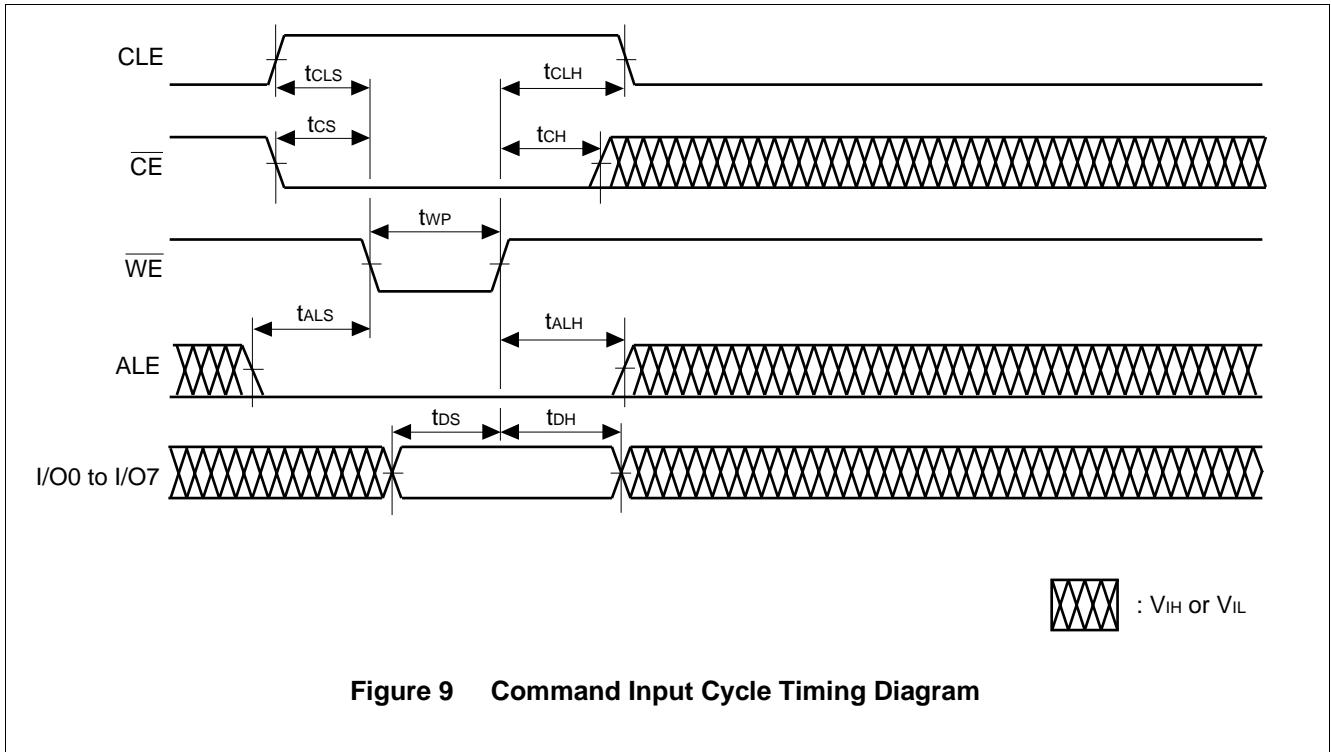

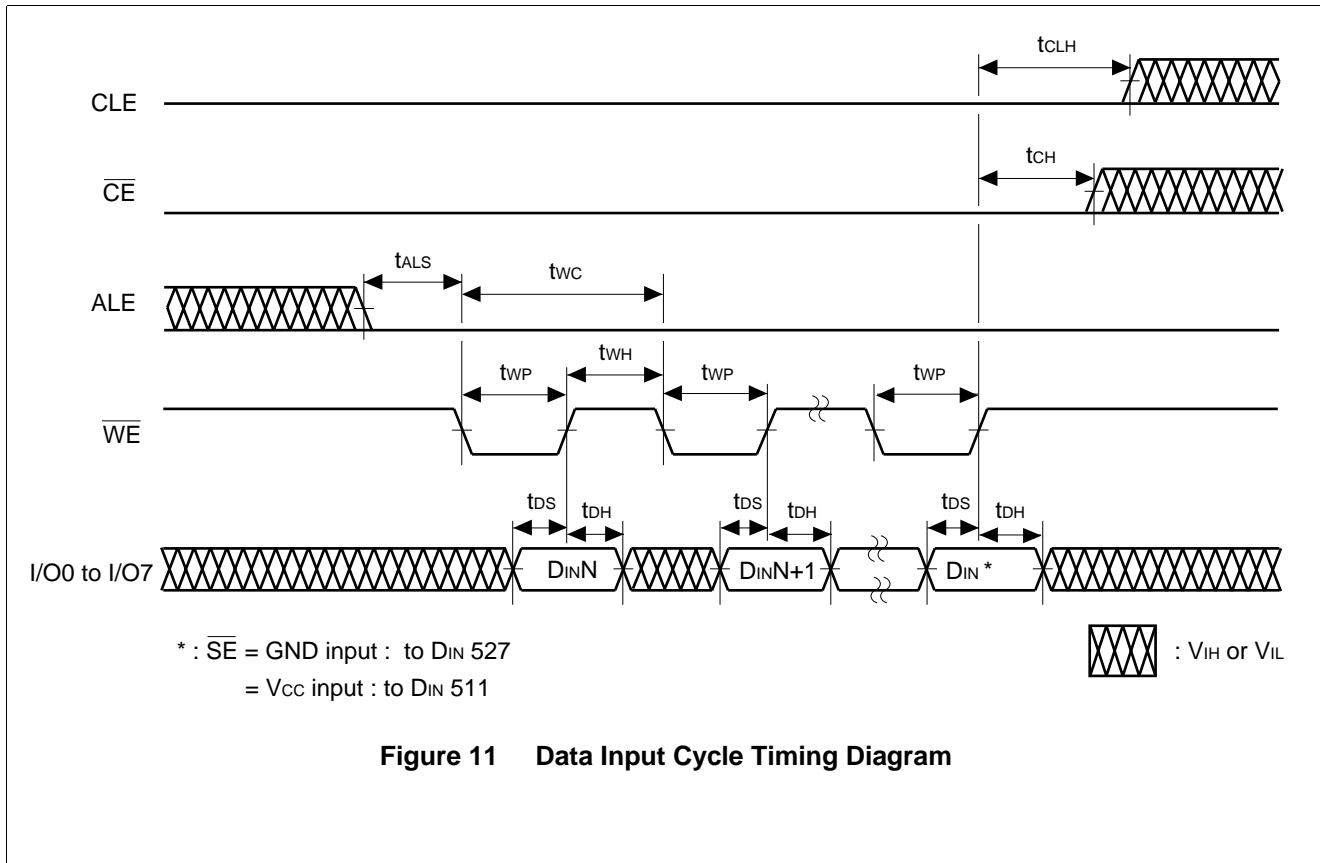
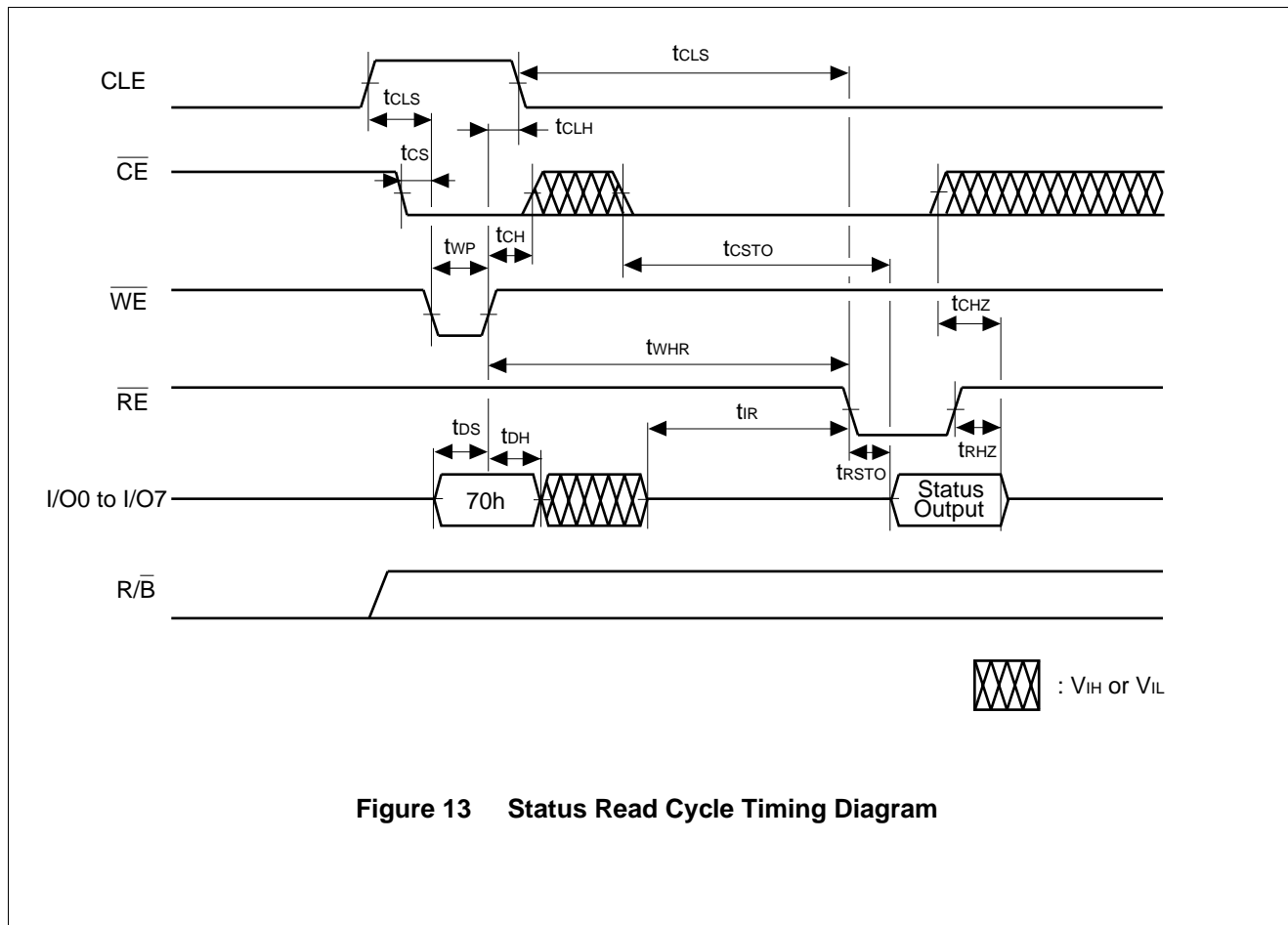
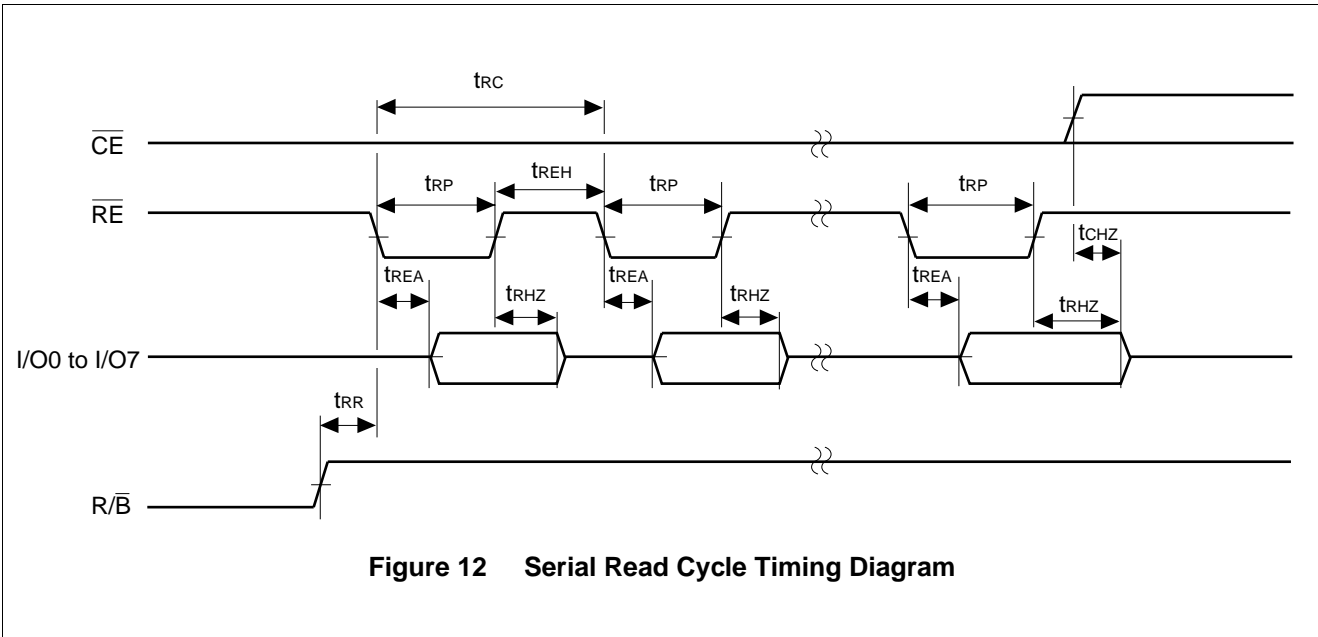
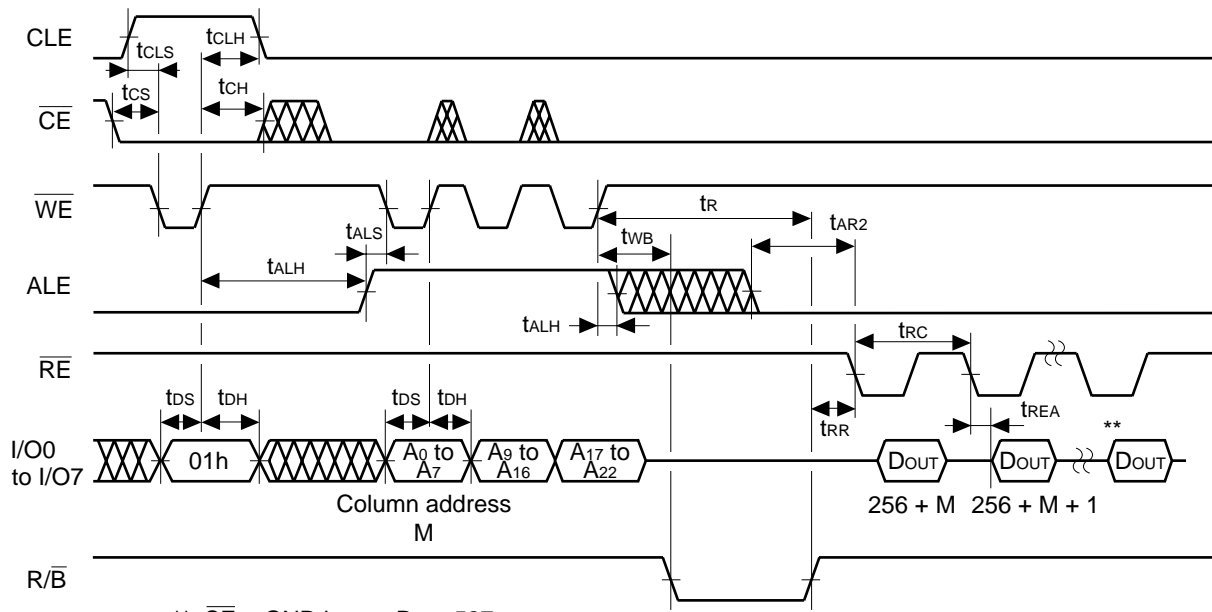

Figure 11 Data Input Cycle Timing Diagram



MBM30LV0064



** : \overline{SE} = GND input : DOUT 527
 = Vcc input : DOUT 511

 : V_{IH} or V_{IL}

Note: The \overline{CE} signal must stay "Low" after the third address input and during Busy state.

Figure 16 Read Cycle (2) Timing Diagram

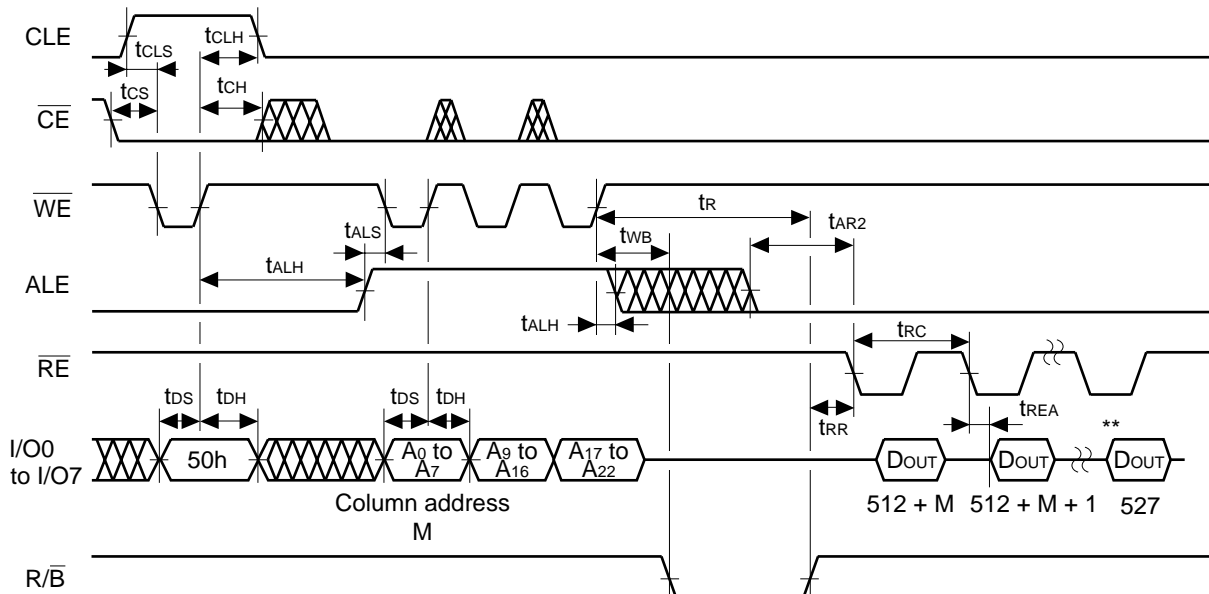

** : \overline{SE} = GND input : DOUT 527
 = Do not input Vcc

 : V_{IH} or V_{IL}

Note: The \overline{CE} signal must stay "Low" after the third address input and during Busy state.

Figure 17 Read Cycle (3) Timing Diagram

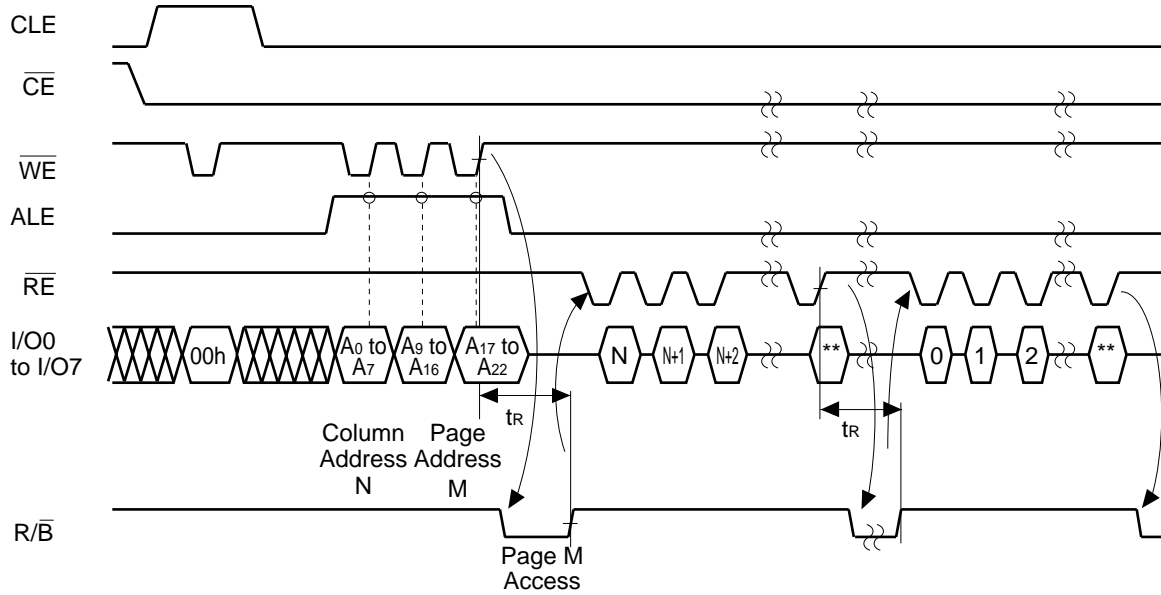

** : $\overline{SE} = \text{GND}$ input : DOUT 527
 = V_{CC} input : DOUT 511

 : V_{IH} or V_{IL}

Note: The \overline{CE} signal must stay "Low" after the third address input and during Busy state.

Figure 18 Sequential Read (1) Timing Diagram

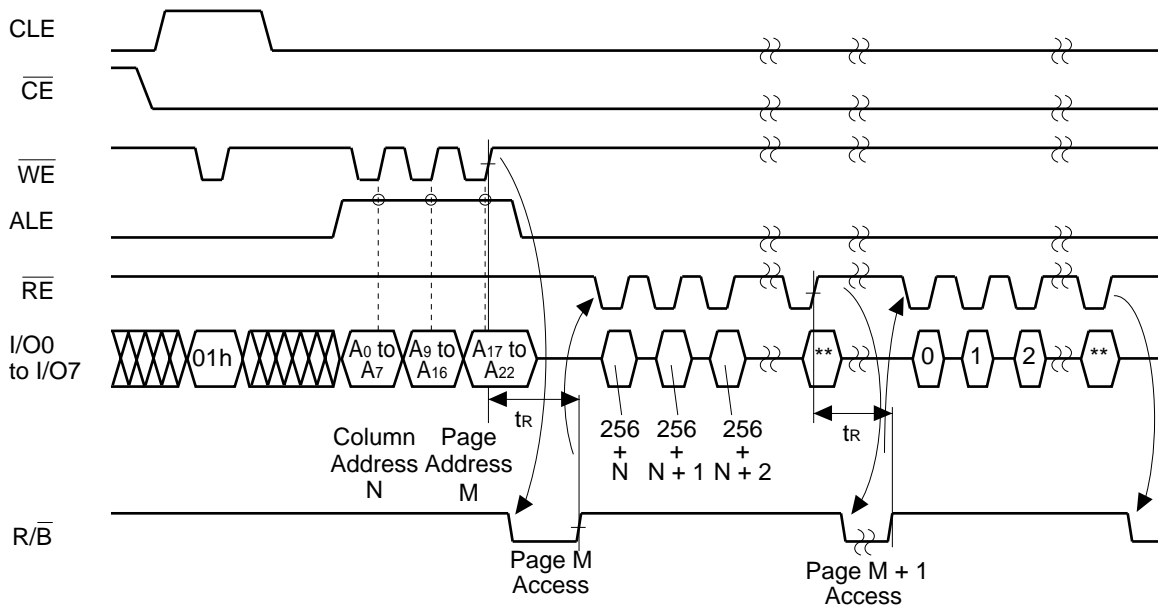

** : $\overline{SE} = \text{GND}$ input : DOUT 527
 = V_{CC} input : DOUT 511

 : V_{IH} or V_{IL}

Note: The \overline{CE} signal must stay "Low" after the third address input and during Busy state.

Figure 19 Sequential Read (2) Timing Diagram

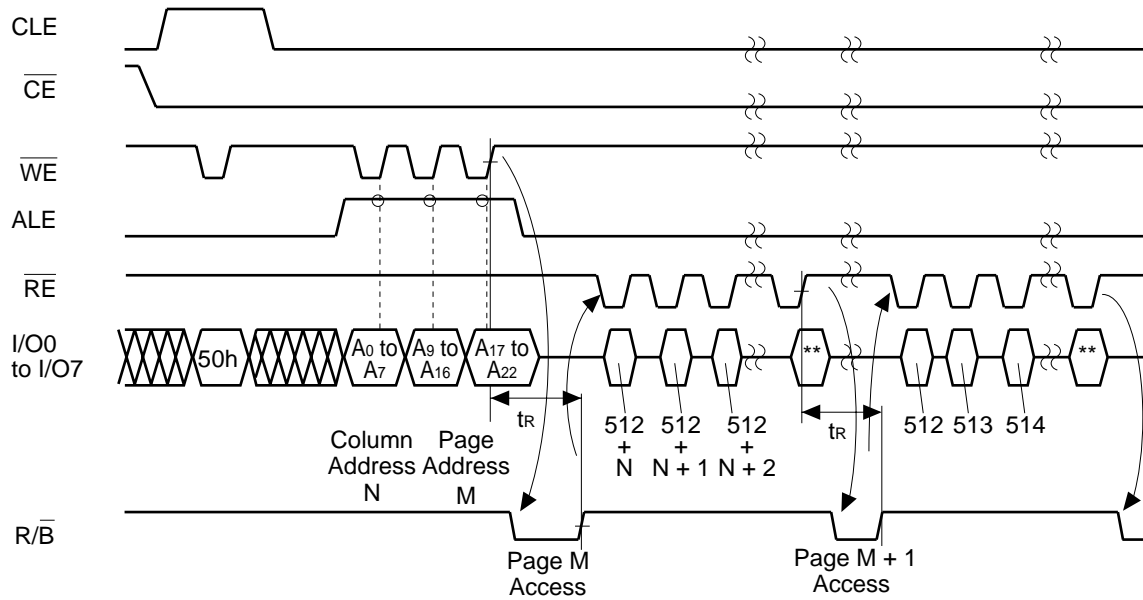

** : \overline{SE} = GND input : DOUT 527
 = Do not input V_{CC}

 : V_{IH} or V_{IL}

Note: The \overline{CE} signal must stay "Low" after the third address input and during Busy state.

Figure 20 Sequential Read Cycle (3) Timing Diagram

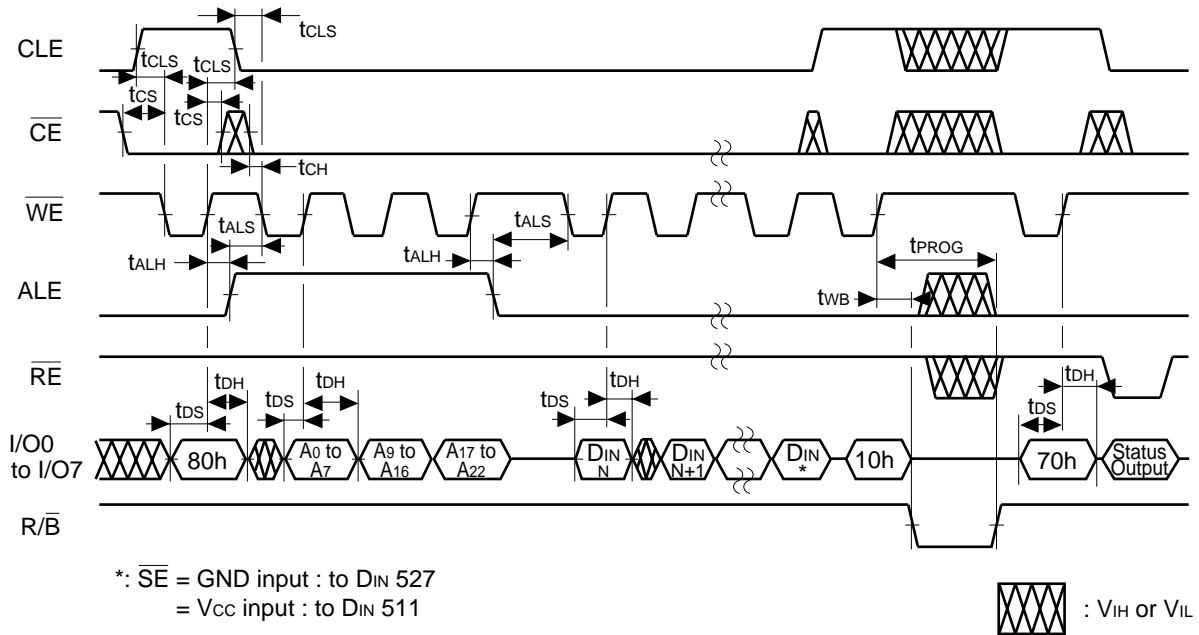

Figure 21 Auto Program Operation Timing Diagram

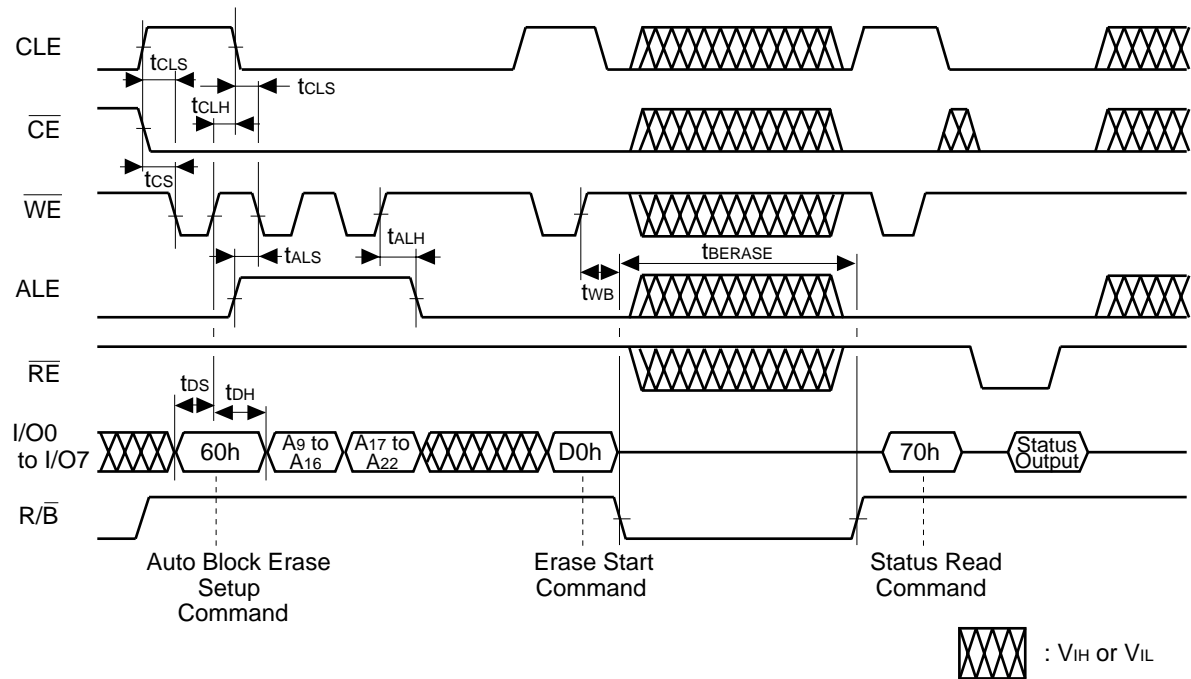

Figure 22 Auto Block Erase Timing Diagram

MBM30LV0064

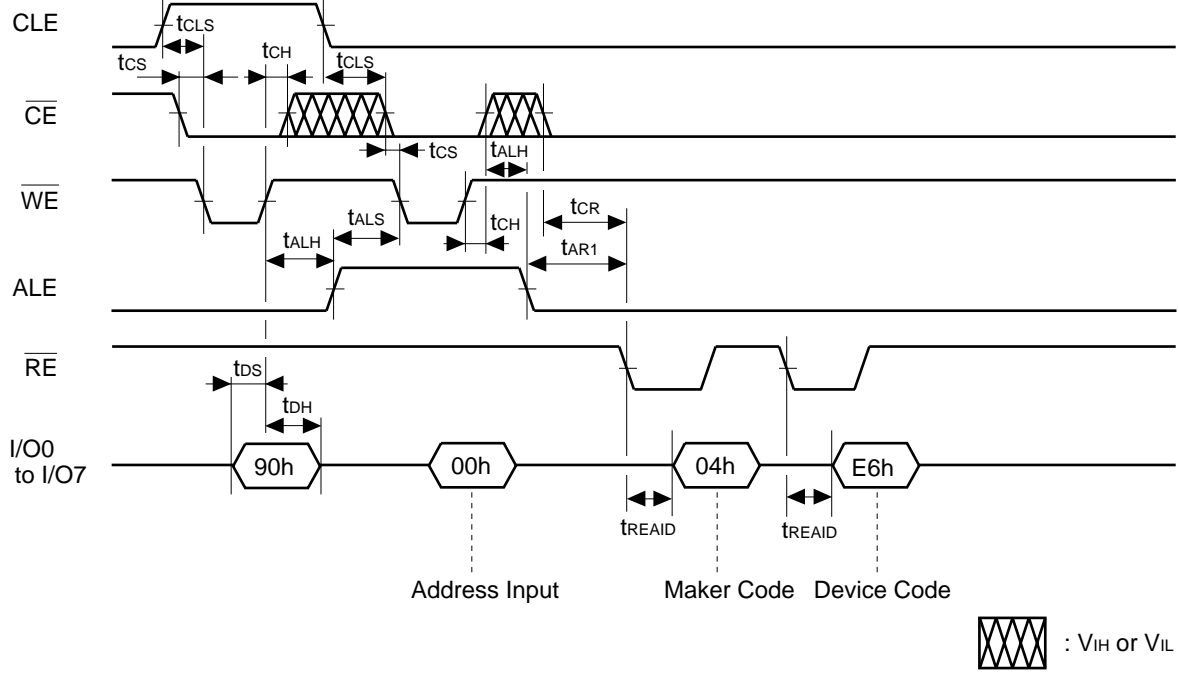

Figure 23 ID Read Operation Timing Diagram

APPLICATION NOTES AND COMMENTS

(1) Prohibition of unspecified commands

The operation commands are listed in Table 4. Data input as a command other than the specified commands in Table 4 is prohibited. Stored data may be corrupted if an unspecified command is entered during the command cycle.

(2) Pointer Action for Program Operation

The pointer action can be done for program operation as follows.

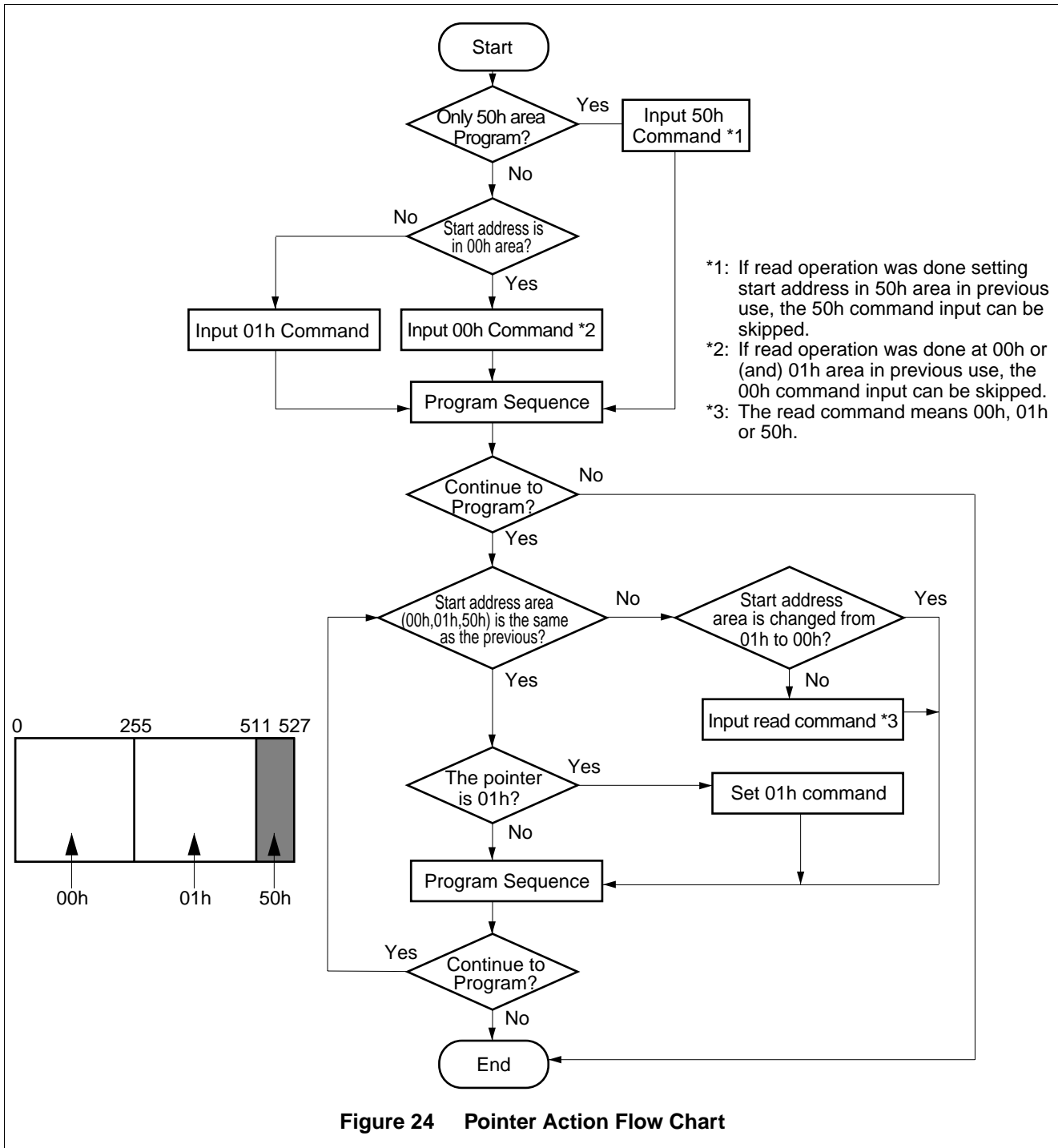

(3) Acceptable commands after serial input command '80h'

When the serial input command (80h) is input for program execution, commands other than the program execution command (10h) or reset command (FFh) should not be input.

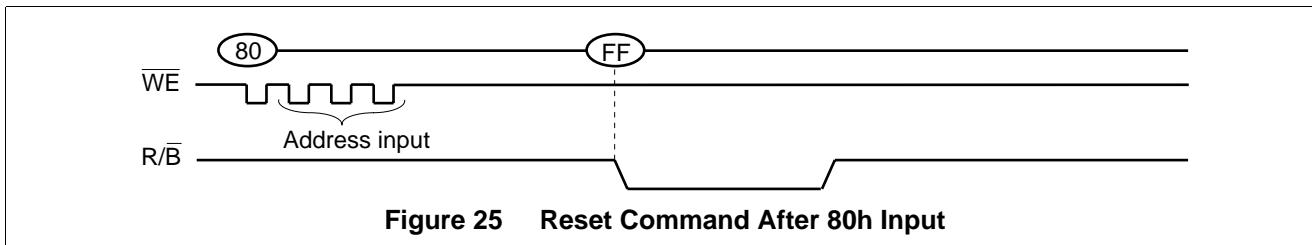

If a command other than '10h' or 'FFh' is input, the program operation is not performed.

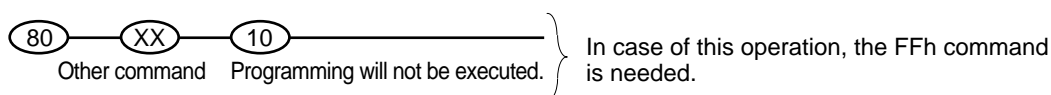

(4) Status read during the read operation

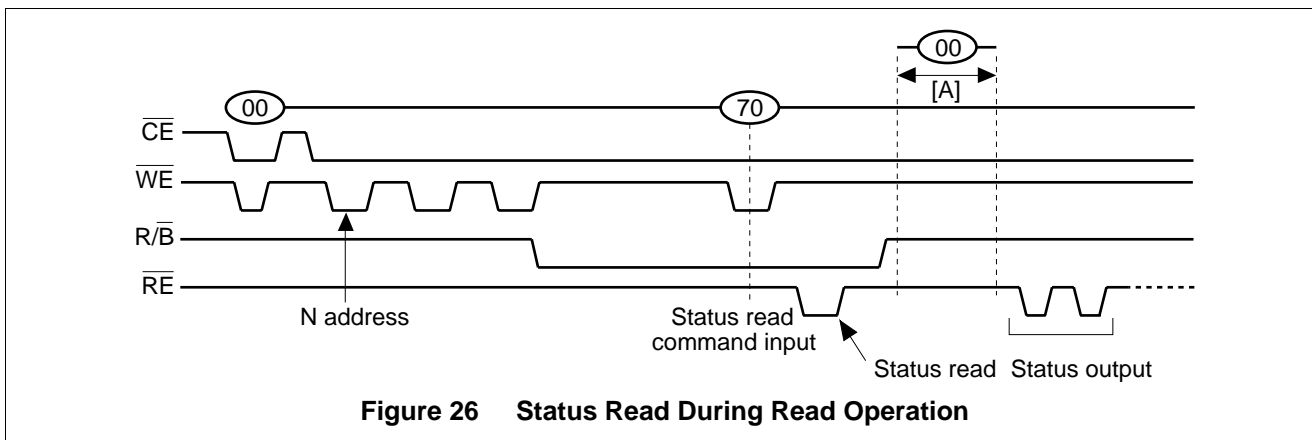

When the status read command (70h) is input during reading, the next \overline{RE} clock signal can be input to read the value of the internal status register.

Since the internal operation mode is held in Status Read, read data will not be output even if the \overline{RE} clock signal is input after becoming ready. Status Read is therefore disabled at reading.

When the read command (00h) is input during the period [A], the internal operation mode of the device can be canceled, making it possible to read data at address N without inputting Add.

(5) Auto program failure

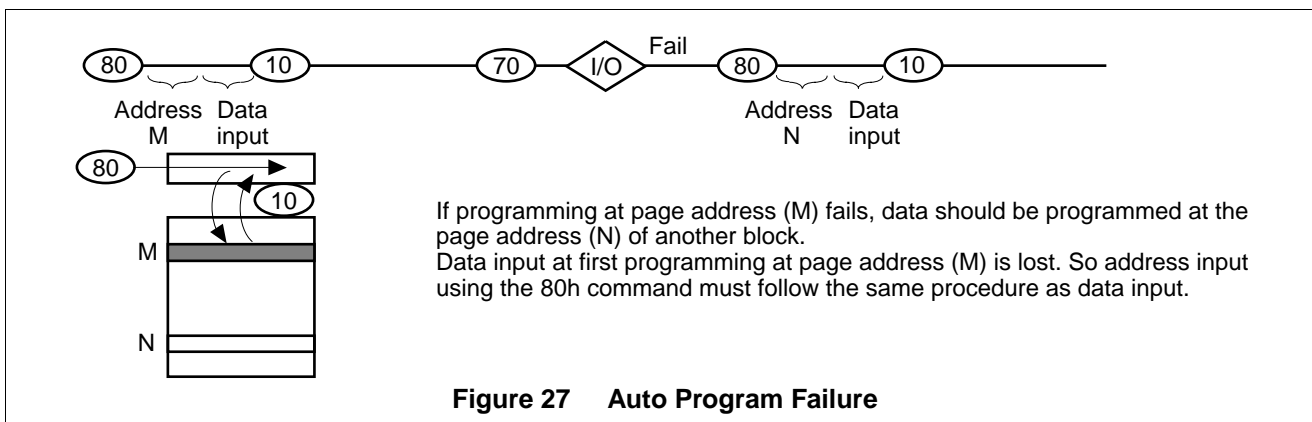

(6) R/\bar{B} : Termination of the Ready/Busy pin (R/\bar{B})

The R/\bar{B} is open-drain output. When using the R/\bar{B} , R/\bar{B} must be pulled up V_{CC} by a resistor.

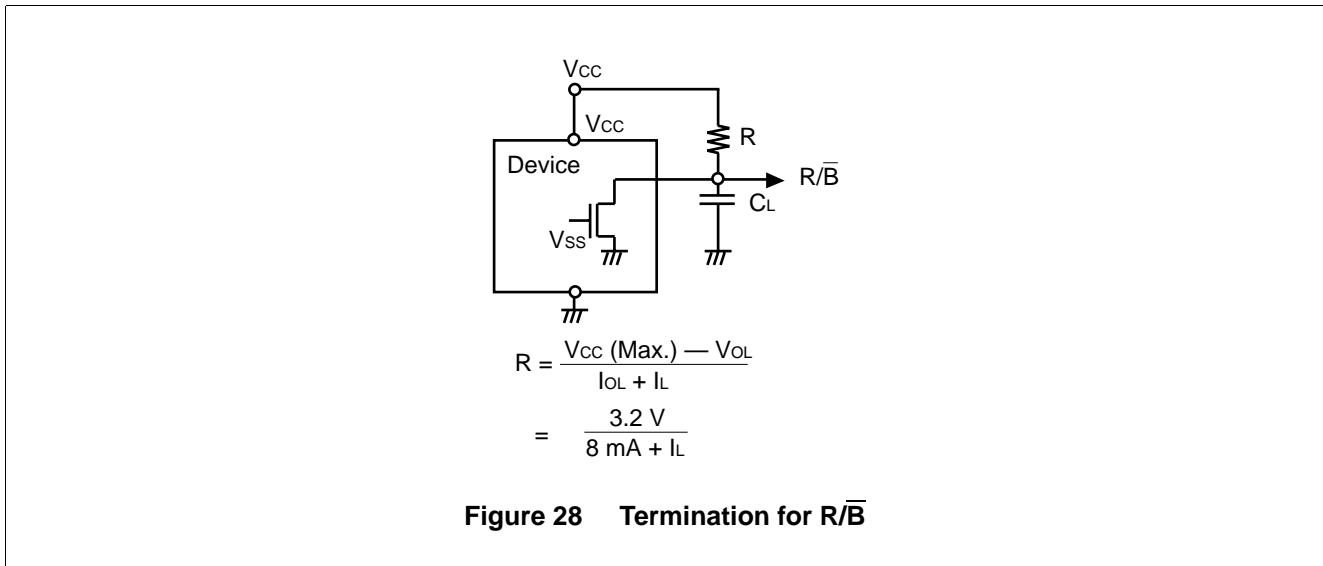

(7) Power On/Off Sequence:

After power-off, each input signal level may be undefined. Use the \overline{WP} signal as shown in the figure below.

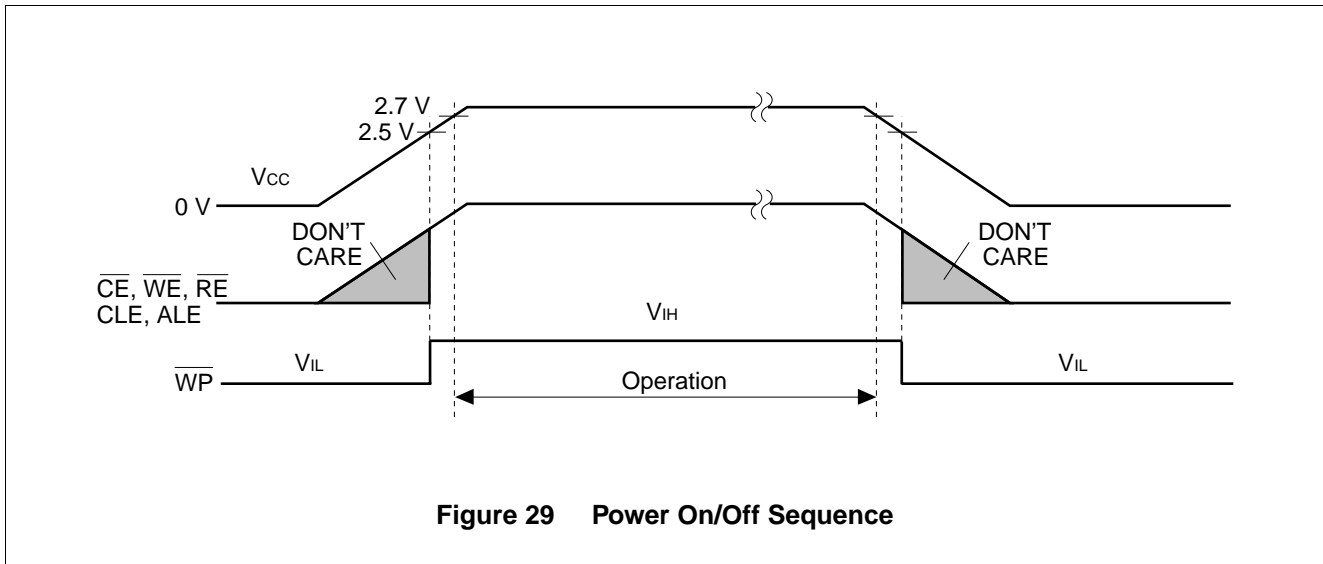

MBM30LV0064

(8) Setup for \overline{WP} Signal

A Low-level \overline{WP} signal will force erasing and programming to be reset. To control, use the \overline{WP} signal as shown below.

Program

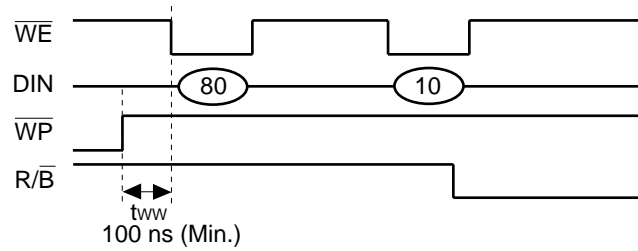

Program Prohibition

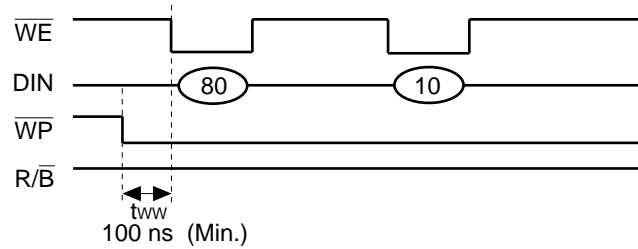

Erase

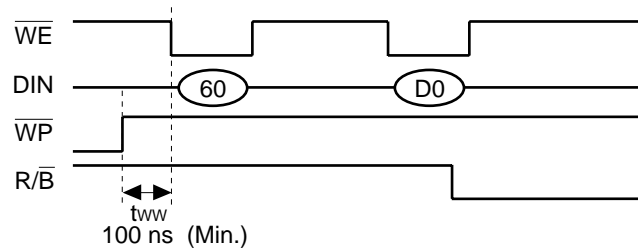

Erase Prohibition

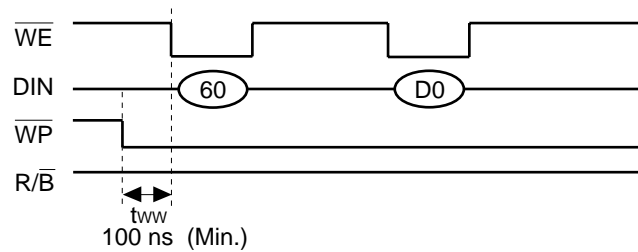

(9) Address input in 4 cycles

The device will get addresses in three cycles. If addresses are input in four cycles, address input in the fourth cycle will be ignored in the chip.

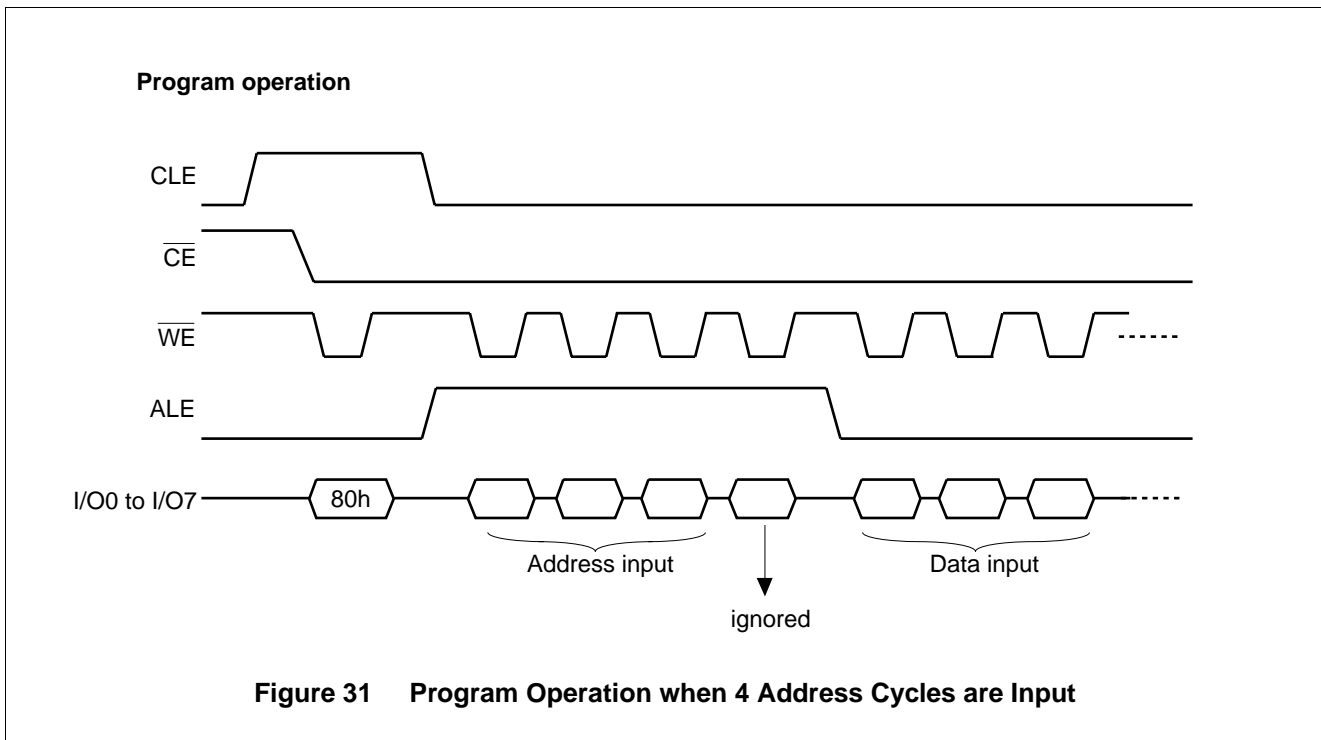
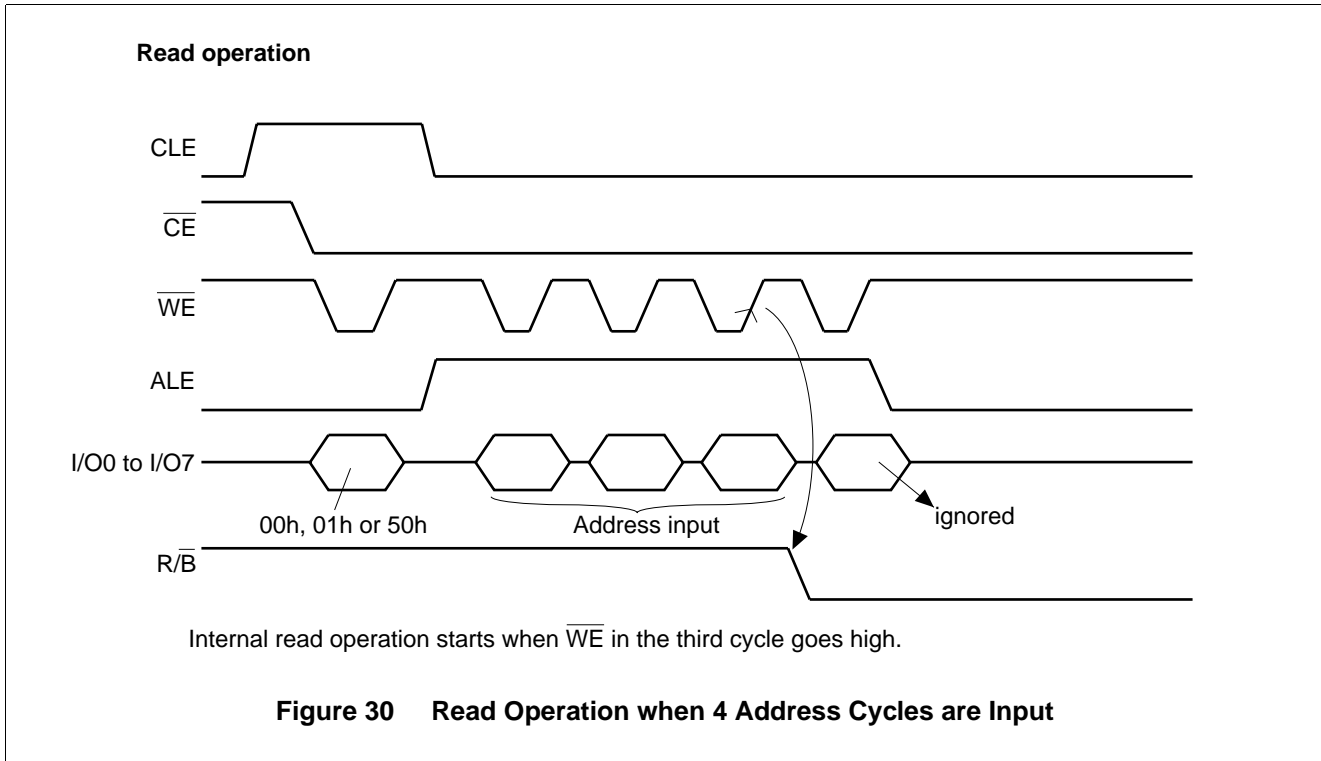

(10) Divided programming on same page

The device uses the page programming method that allows programming up to ten times on the same page. The procedure for divided programming (programming on a part of one page) is shown below.

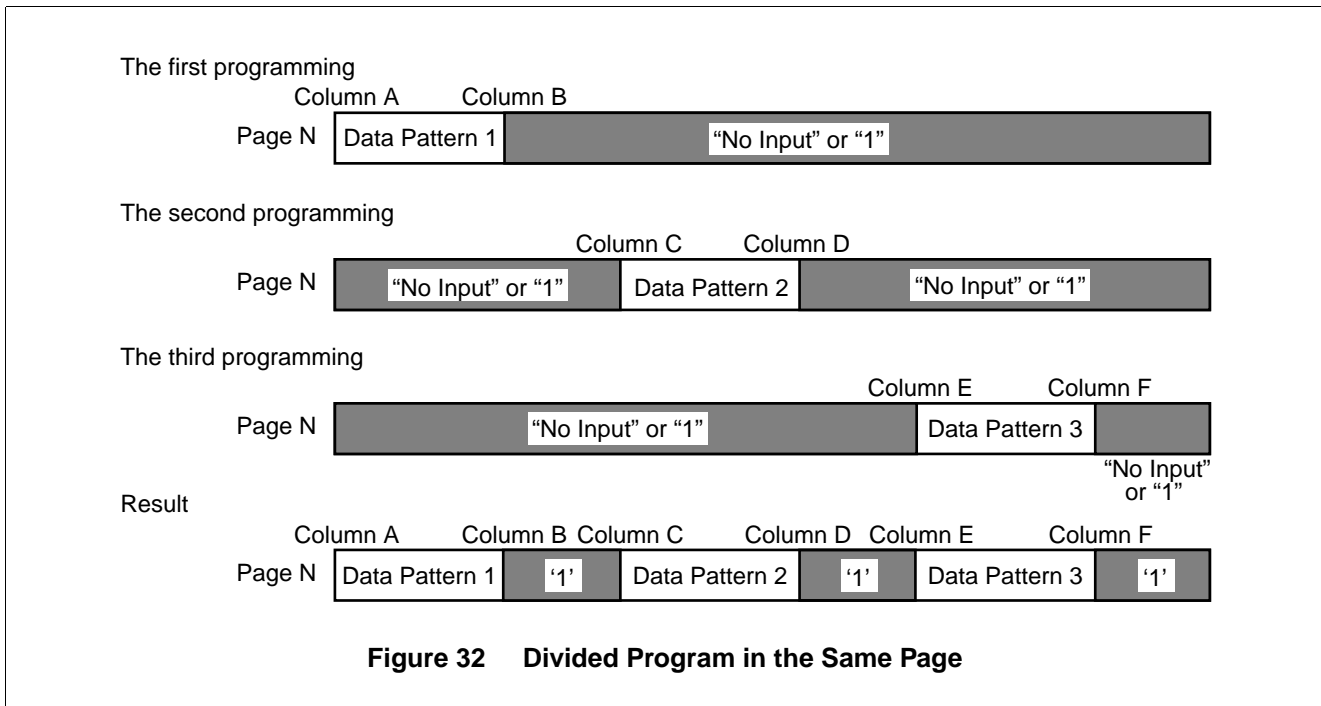

(11) Notification for \overline{RE} Signal

When the device is in the read mode, the \overline{RE} signal causes the internal column address counter to increment in synchronization with the \overline{RE} clock. If the 00h, 01h, or 50h command is input to the device in the read mode, the internal column address counter will count up even after the \overline{RE} signal is input prior to address input. At this mode, at input of the \overline{RE} signal beyond the last column address, the device will start reading (Memory → register) even without address input and may output the Busy signal (Sequential Read is started).

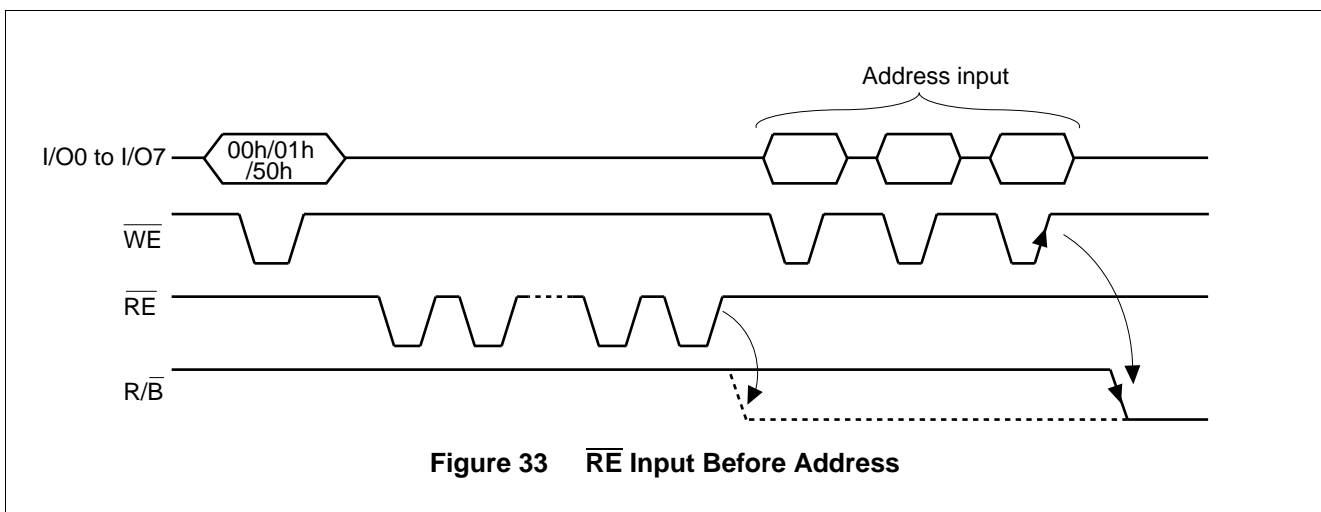

In this way, once the device enters the read mode, unintentional reading may be started after the \overline{RE} signal is input prior to addressing; therefore, the \overline{RE} signal should be input after address input.

(12) Invalid block (bad block)

The device contains unusable blocks. Therefore, the following issues must be recognized:

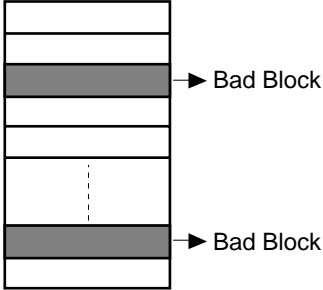

The diagram shows a vertical stack of memory blocks. Two blocks are shaded grey and labeled 'Bad Block' with arrows pointing to them. A dashed vertical line is shown in the middle of the stack.

Some MBM30LV0064 products have invalid blocks (bad blocks) at shipping. After mounting the device in the system, test whether there are no bad blocks. If there are any bad blocks, they should not be accessed.

The bad blocks are connected to sense-amp of the bit lines via the selector transistors. Good blocks will not be affected unless the bad blocks are accessed. The effective number of good blocks specified by Fujitsu is shown below.

	Min.	Typ.	Max.	Unit
Valid (Good) Block Number	1014	1020	1024	Block

Figure 36. Shows the Bad Block Test Flow

Figure 34 Bad Block

(13) Failure Phenomena for Program and Erase Operations

Repeated rewriting might cause an error at programming and erasing. Possible error modes, and detection methods and remedies are listed in the following table. System-based remedies will provide a highly reliable system.

Failure Mode		Detection and Countermeasure Sequence
Block	Erase Failure	Status Read after Erase → Block Replacement
Page	Program Failure	Status Read after Prog. → Block Replacement
Single Bit*	Program Failure '1' → '0'	(1) Block Verify after Prog. → Retry
		(2) ECC

* : (1) or (2)

- ECC : Error Correcting code → Hamming Code etc.
Example : 1 bit correction & 2 bit detection.
- Block Replacement

Program

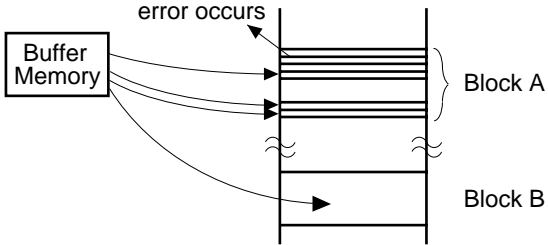

The diagram shows a 'Buffer Memory' box on the left. Arrows point from it to 'Block A' and 'Block B' on the right. An arrow points to the top of Block A with the text 'error occurs'. Block A is represented by a stack of horizontal lines, while Block B is a single line.

If an error occurs in block A, reprogramming from the external buffer to block B. Block A should not be accessed after an error occurs.

Figure 35 Reprogramming to Good Block

Erase

If an error occurs at erasing, like programming, remedies should be executed on a system basis to prevent access to blocks causing the error.

(14) ALE Input Condition during Address Input

The ALE input must remain high once asserted until the last address byte has been written to the device.

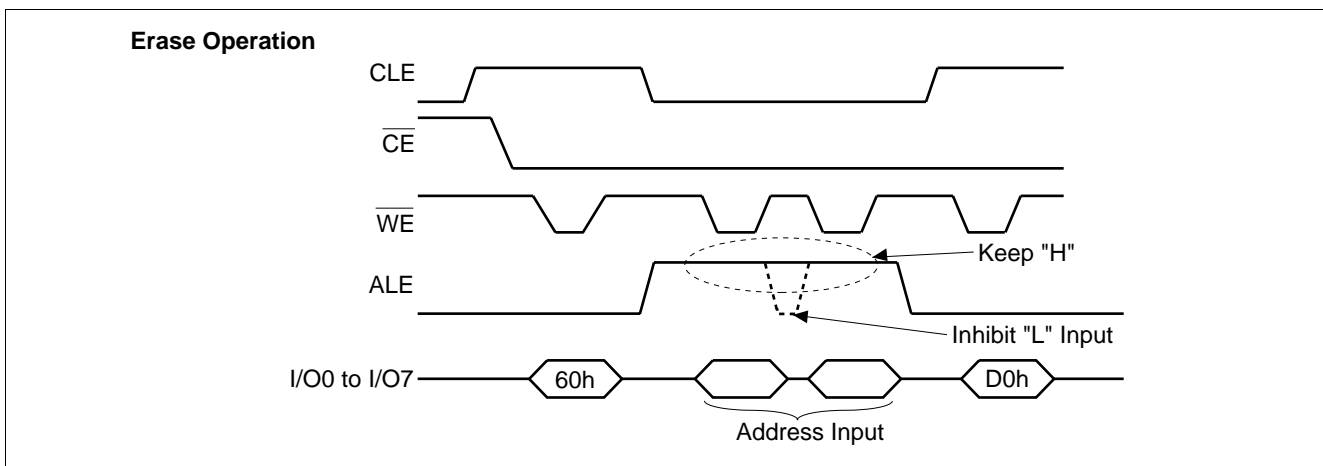
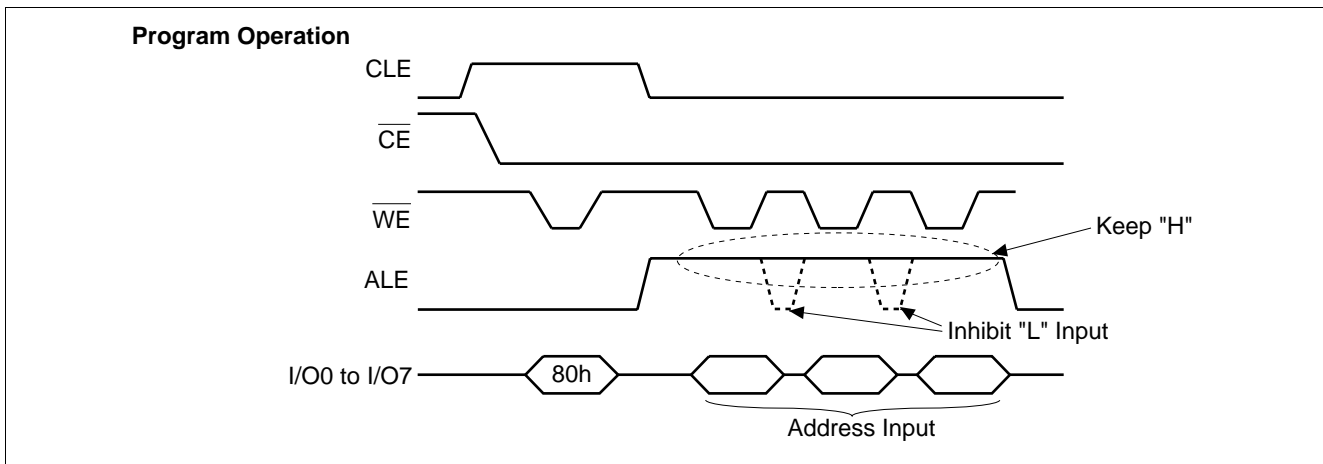
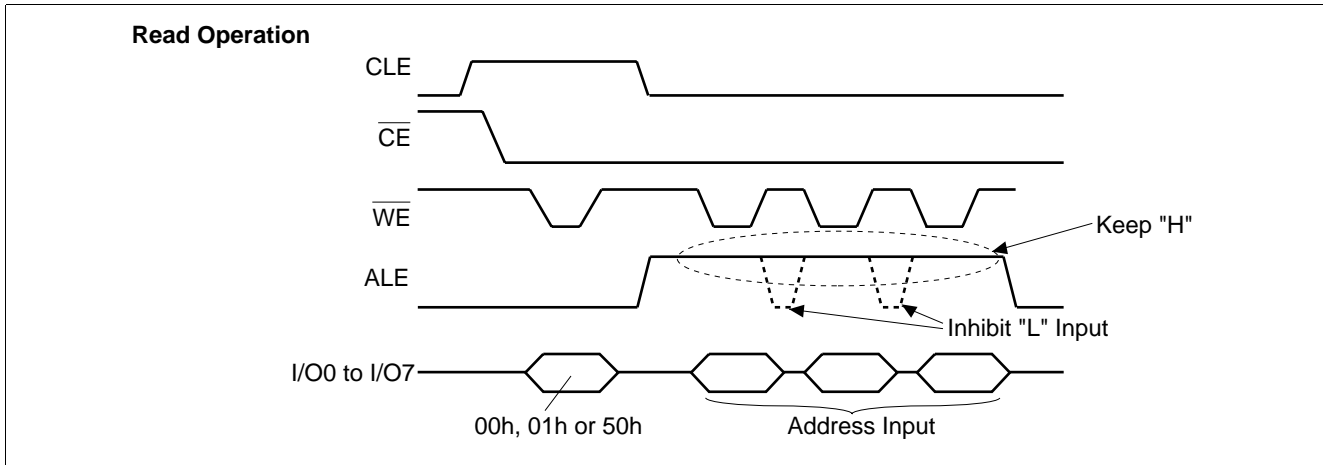

(15) Inhibit \overline{RE} Toggling during Busy State

The \overline{RE} input cannot be allowed to toggle during the period that a read data transfer operation is in process (busy state).

If the \overline{RE} input toggles during that period, the internal column address will increment.

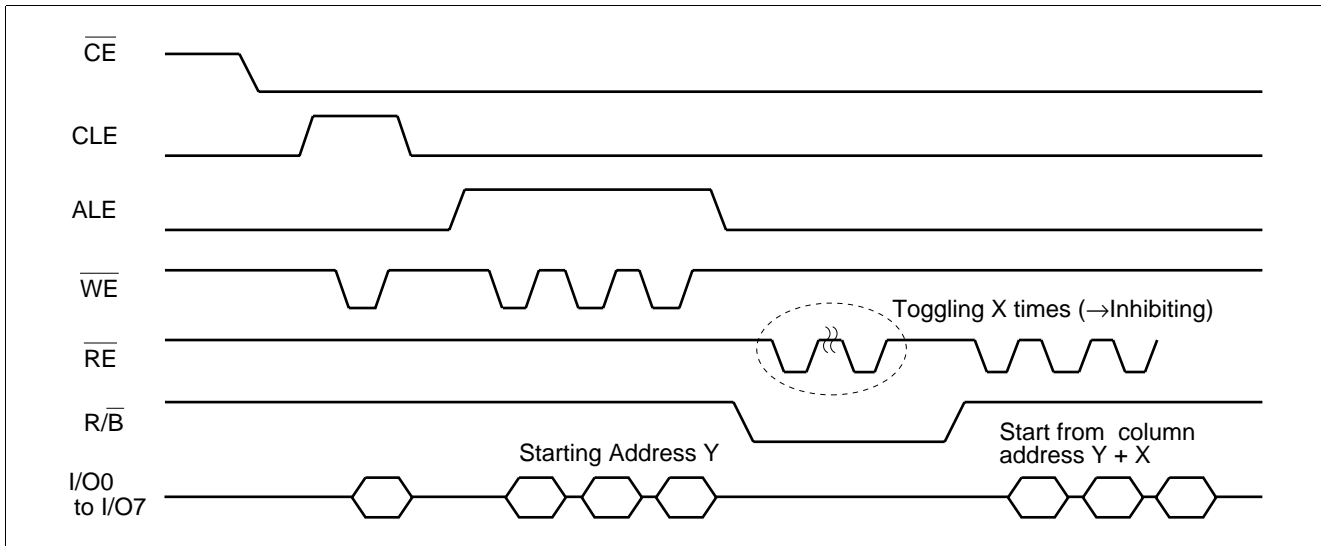

(16) Restriction on Toggling the \overline{WE}

The \overline{WE} input cannot be allowed to toggle past the end of page (byte 511 with \overline{SE} high or byte 527 with \overline{SE} low) during an input data operation. If the \overline{WE} input toggles past the end of page, the internal address counter will wrap around to the beginning of the page and overwrite the information previously there.

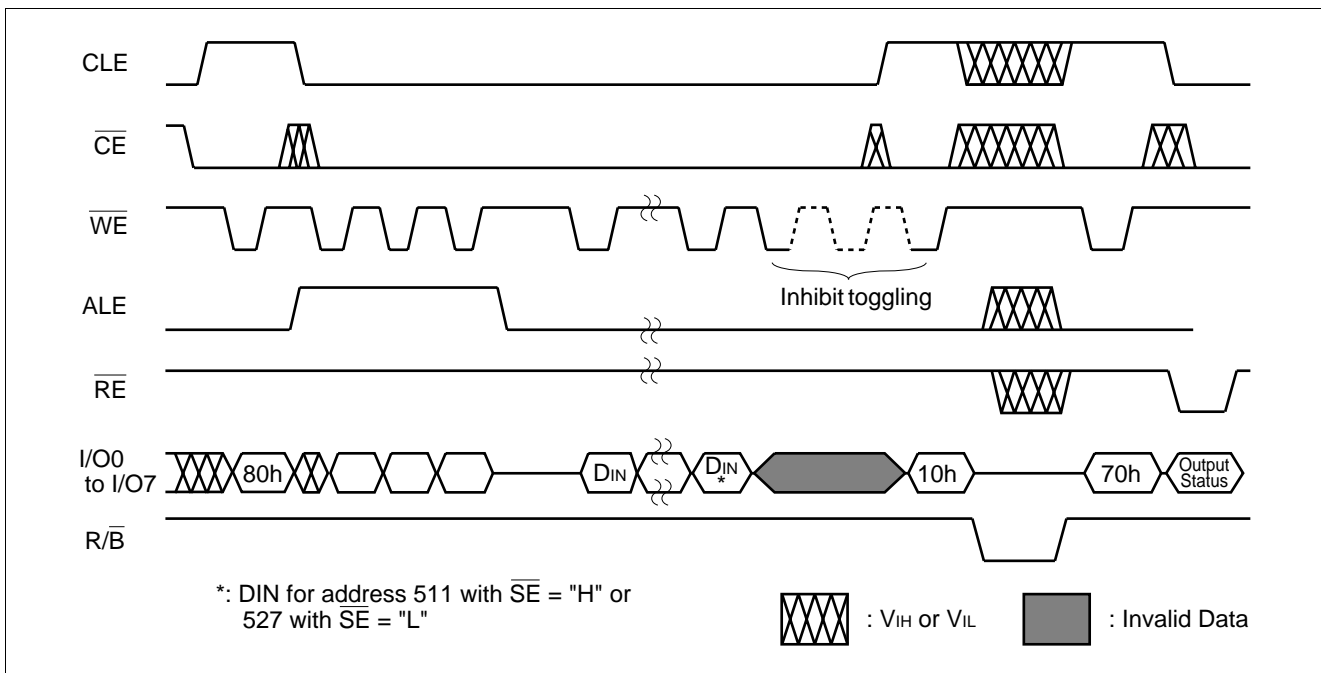

(17) Reading Past Last Device Page

When the last byte in the last page of the device is read, the internal address counter will wrap around to the first page in the device.

MBM30LV0064

(18) \overline{CE} don't care timing for read and program operation

\overline{CE} can be don't-care ("H" or "L") state during read and program operation as follows.

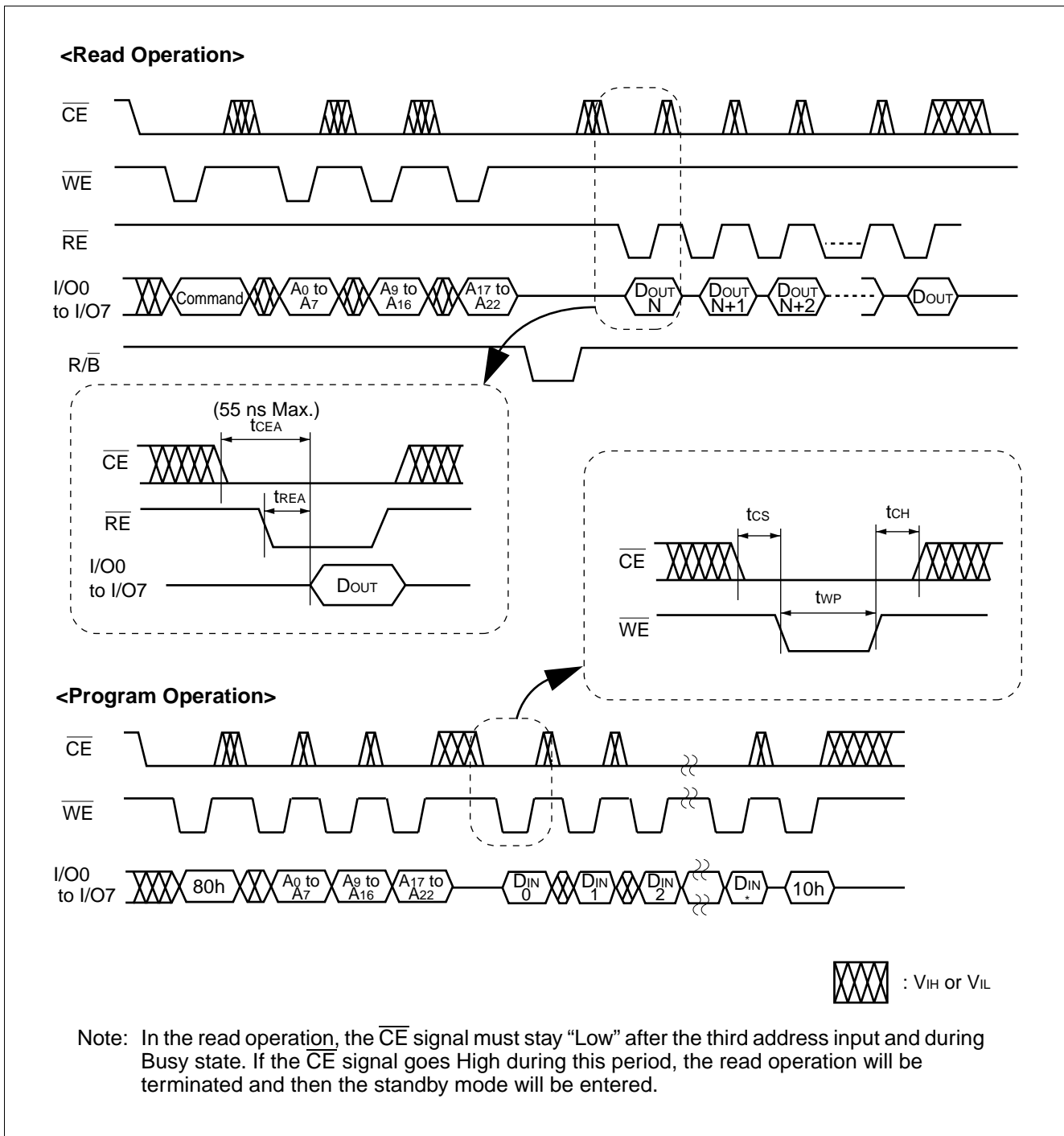

■ BAD BLOCK TEST FLOW

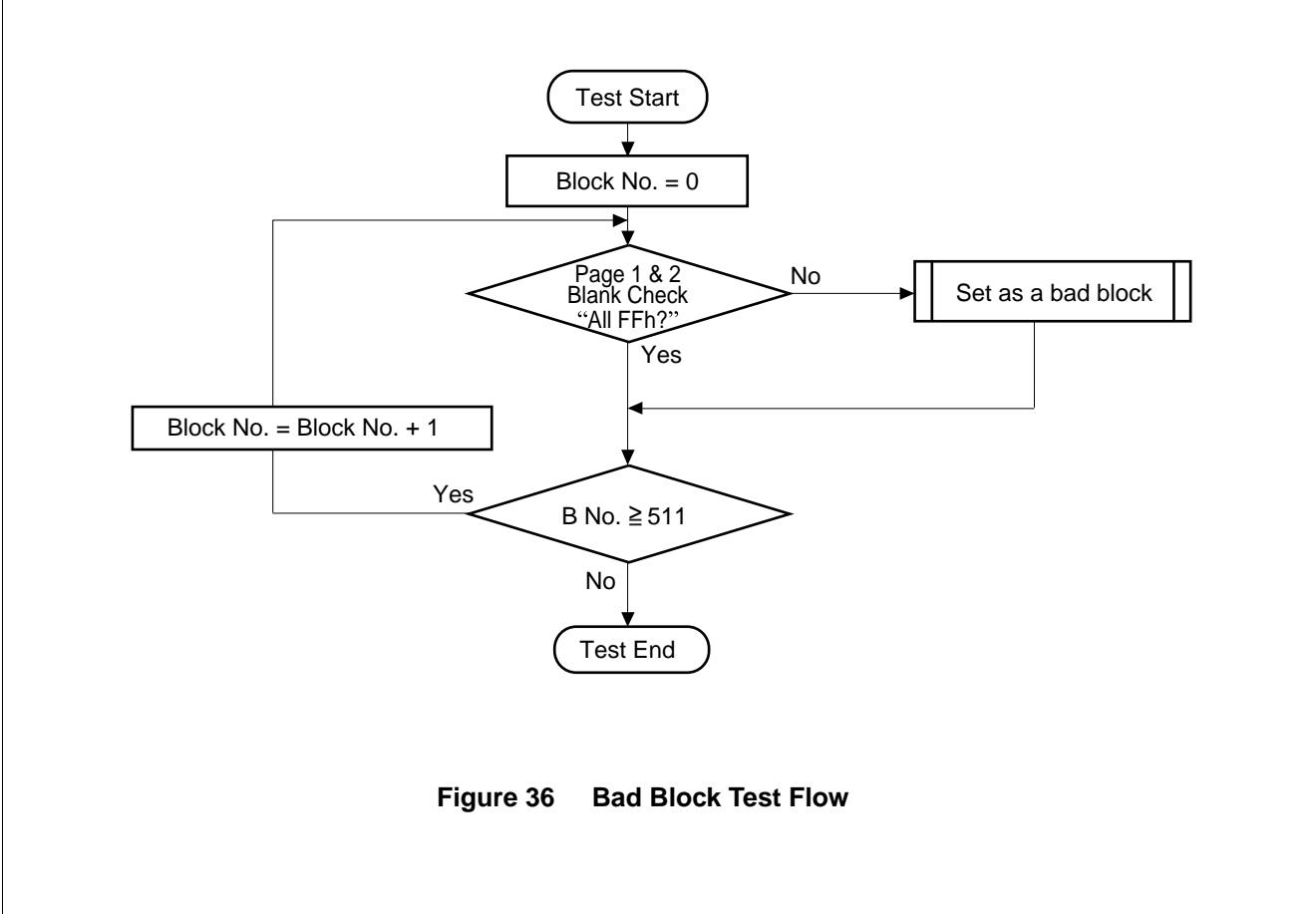

Figure 36 Bad Block Test Flow

MBM30LV0064

■ ORDERING INFORMATION

Standard Products

Fujitsu standard products are available in several packages. The order number is formed by a combination of:

MBM30LV0064

-PFTN

PACKAGE TYPE

PFTN = 44-Pin Thin Small Outline Package
(TSOP) Standard Pinout

PFTR = 44-Pin Thin Small Outline Package
(TSOP) Reverse Pinout

DEVICE NUMBER/DESCRIPTION

MBM30LV0064

64 Mega-bit (8M × 8-Bit) CMOS Flash Memory
2.7 V to 3.6 V Read, Write, and Erase

Valid Combinations	
MBM30LV0064	-PFTN -PFTR

Valid Combinations

Valid Combinations list configurations planned to be supported in volume for this device. Consult the local Fujitsu sales office to confirm availability of specific valid combinations and to check on newly released combinations.

■ PACKAGE DIMENSIONS

44-pin plastic TSOP (II)
(FPT-44P-M07)

*: Resin protrusion. (Each side: 0.15(.006) Max)

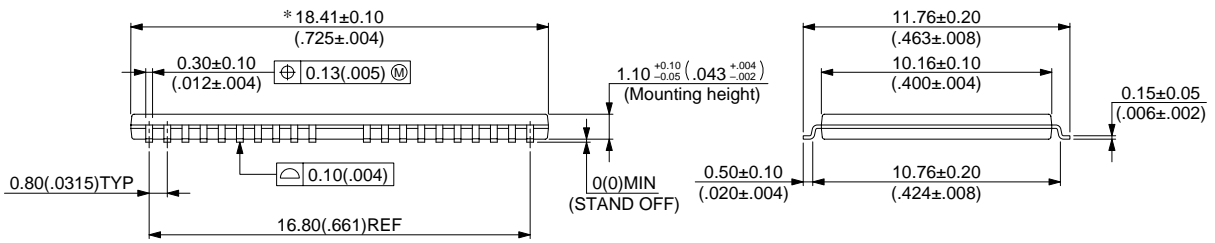
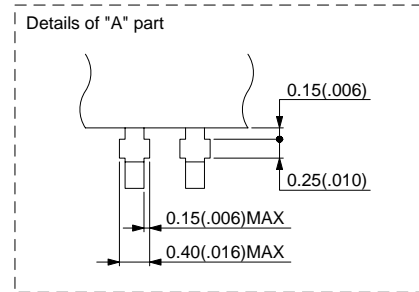
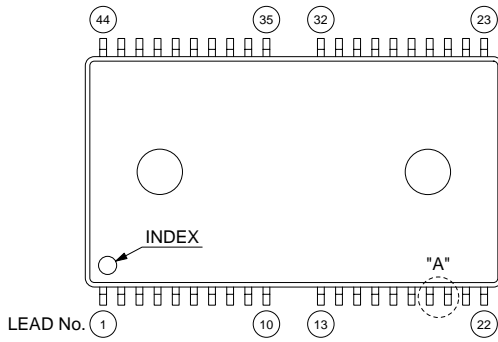

© 2000 FUJITSU LIMITED F44016S-1C-3

Dimensions in mm (inches)

(Continued)

MBM30LV0064

(Continued)

44-pin plastic TSOP (II)
(FPT-44P-M08)

*: Resin protrusion. (Each side: 0.15(.006) Max)

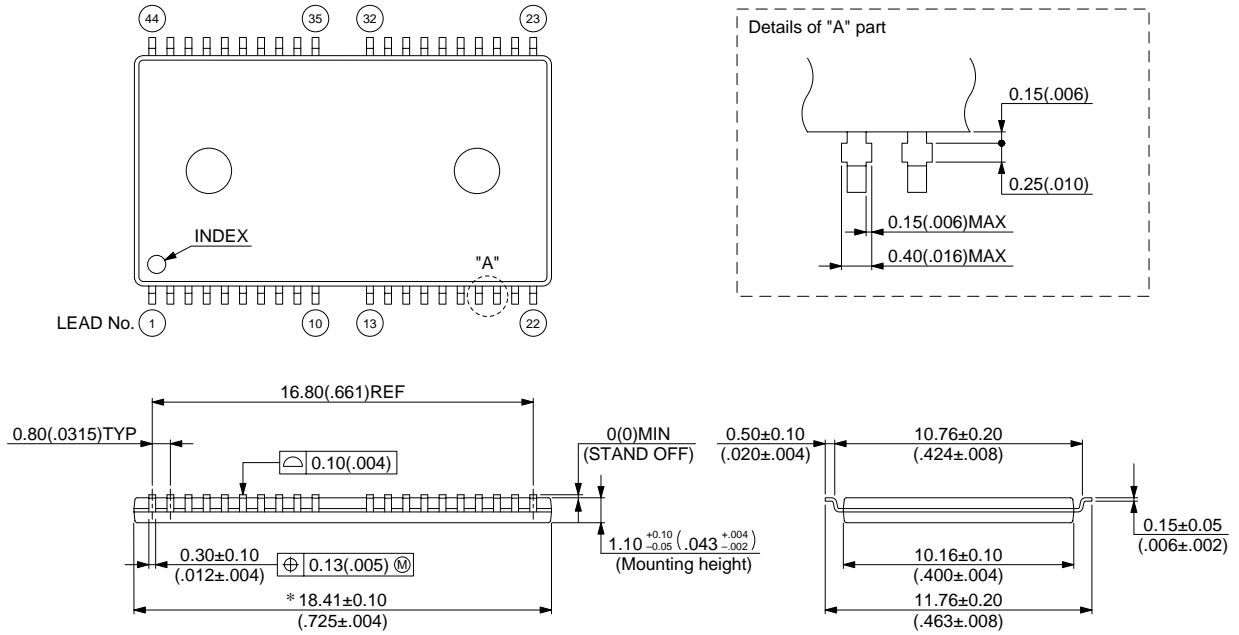

© 2000 FUJITSU LIMITED F44017S-1C-3

Dimensions in mm (inches)

FUJITSU LIMITED

For further information please contact:

Japan

FUJITSU LIMITED
Corporate Global Business Support Division
Electronic Devices
Shinjuku Dai-Ichi Seimei Bldg. 7-1,
Nishishinjuku 2-chome, Shinjuku-ku,
Tokyo 163-0721, Japan
Tel: +81-3-5322-3347
Fax: +81-3-5322-3386

<http://edevice.fujitsu.com/>

North and South America

FUJITSU MICROELECTRONICS, INC.
3545 North First Street,
San Jose, CA 95134-1804, U.S.A.
Tel: +1-408-922-9000
Fax: +1-408-922-9179

Customer Response Center
Mon. - Fri.: 7 am - 5 pm (PST)
Tel: +1-800-866-8608
Fax: +1-408-922-9179

<http://www.fujitsumicro.com/>

Europe

FUJITSU MICROELECTRONICS EUROPE GmbH
Am Siebenstein 6-10,
D-63303 Dreieich-Buchsschlag,
Germany
Tel: +49-6103-690-0
Fax: +49-6103-690-122

<http://www.fujitsu-fme.com/>

Asia Pacific

FUJITSU MICROELECTRONICS ASIA PTE. LTD.
#05-08, 151 Lorong Chuan,
New Tech Park,
Singapore 556741
Tel: +65-281-0770
Fax: +65-281-0220

<http://www.fmap.com.sg/>

Korea

FUJITSU MICROELECTRONICS KOREA LTD.
1702 KOSMO TOWER, 1002 Daechi-Dong,
Kangnam-Gu, Seoul 135-280
Korea
Tel: +82-2-3484-7100
Fax: +82-2-3484-7111

F0012

© FUJITSU LIMITED Printed in Japan

All Rights Reserved.

The contents of this document are subject to change without notice. Customers are advised to consult with FUJITSU sales representatives before ordering.

The information and circuit diagrams in this document are presented as examples of semiconductor device applications, and are not intended to be incorporated in devices for actual use. Also, FUJITSU is unable to assume responsibility for infringement of any patent rights or other rights of third parties arising from the use of this information or circuit diagrams.

The contents of this document may not be reproduced or copied without the permission of FUJITSU LIMITED.

FUJITSU semiconductor devices are intended for use in standard applications (computers, office automation and other office equipments, industrial, communications, and measurement equipments, personal or household devices, etc.).

CAUTION:

Customers considering the use of our products in special applications where failure or abnormal operation may directly affect human lives or cause physical injury or property damage, or where extremely high levels of reliability are demanded (such as aerospace systems, atomic energy controls, sea floor repeaters, vehicle operating controls, medical devices for life support, etc.) are requested to consult with FUJITSU sales representatives before such use. The company will not be responsible for damages arising from such use without prior approval.

Any semiconductor devices have inherently a certain rate of failure. You must protect against injury, damage or loss from such failures by incorporating safety design measures into your facility and equipment such as redundancy, fire protection, and prevention of over-current levels and other abnormal operating conditions.

If any products described in this document represent goods or technologies subject to certain restrictions on export under the Foreign Exchange and Foreign Trade Control Law of Japan, the prior authorization by Japanese government should be required for export of those products from Japan.