

NOTES:

1. ITEM 1 NOT AVAILABLE AS STANDARD.
2. Ⓢ REPRESENTS A CRITICAL DIMENSION.
3. MAXIMUM BURR ALLOWANCE: .038 [.0015].
4. MINIMUM PUSHOUT FORCE: 2.22N [.5LB].
5. PARTS TO BE PACKAGED IN TRAYS.

REVISION

0	DF	D FRALEY
2/5/2008	ECN-85872	
ISSUE FOR REVIEW.		
A	QZ	D Fletcher
5/14/2008	ECN-90840	
RELEASE FOR PRODUCTION; BOM; CHG ITEM 5 FROM ASP TRAY TO TY-ASP123.		
B	MM	J FREEMAN
2/17/2009	ECN-105620	
TOP VIEW: CHG FORMULA FOR BODY LENGTH FROM "17 X.800+7.50" TO "17 X.800+7.80"		
C	LF	E Fox
6/4/2009	ECN-111454	
SHT 1, TOP VIEW: CHG DIM "21.40" TO "21.10"; FRONT VIEW: CHG DIM "19.70" TO "19.40"		
D	JB	Z Paden
3/2/2010	ECN-126366	
SHT 2, RECOMMENDED PCB LAYOUT: DEL 4.90(TYP), ADD 1.80 REF, CHG 5.61 TO 5.60, CHG Ø0.83±0.02 TO Ø0.83±0.05, ADD NOTE "TO BE SOLDERED USING PASTE-IN-HOLE TECHNOLOGY"; RECOMMENDED STENCIL LAYOUT: CHG Ø1.58 (2 PLCS) TO Ø2.24(2 PLCS).		

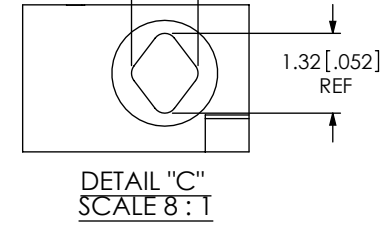
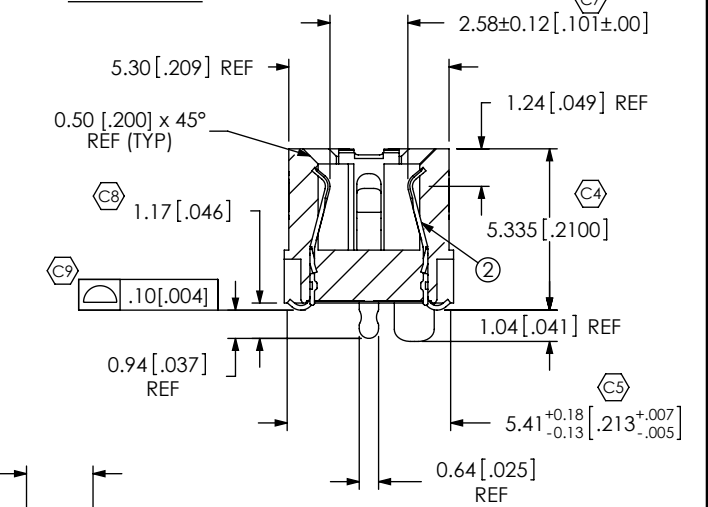
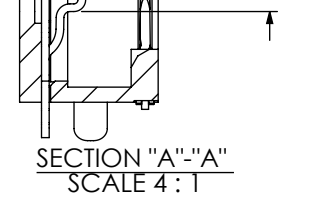
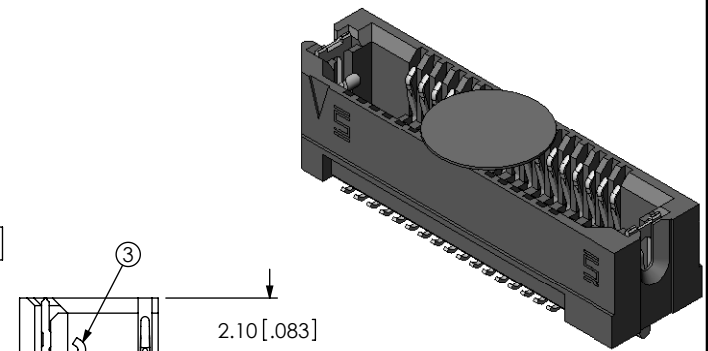
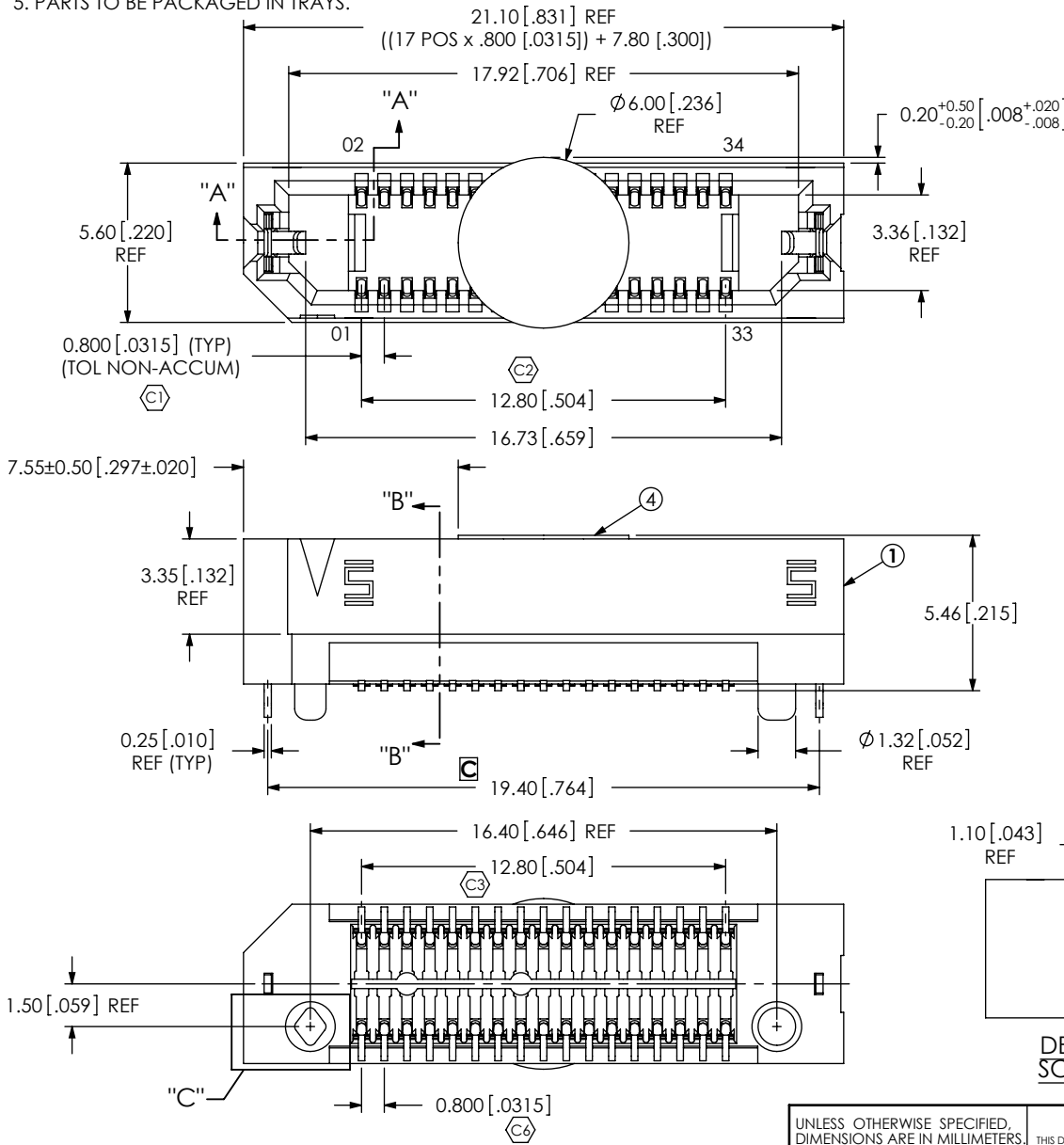

ACCEPTANCE OF DRAWING
 ACCEPTED WITH DEVIATIONS LISTED

DATE: _____
 COMPANY: _____
 CUSTOMER SIGNATURE _____
 PRINTED NAME _____
 PHONE No: _____
 FAX No: _____

ITEM NO.	PART NUMBER	QUANTITY	MATERIAL
1	ASP-136451-03-B	1.0000	VECTRA E130i, COLOR: BLACK
2	C-211-05.0-S	34.0000	BeCu, 390 HT
3	WT-30-01-F	2.0000	BeCu, #25, 1/2 HT
4	K-500-300	1.0000	POLYIMIDE FILM
5	TY-ASP123	1.0000	ANTI-STATIC BLACK HIPS

UNLESS OTHERWISE SPECIFIED, DIMENSIONS ARE IN MILLIMETERS. TOLERANCES ARE:
 DECIMALS ANGLES
 .X: ±.3[.01] 2°
 .XX: ±.13[.005]
 .XXX: ±.051[.0020]

PROPRIETARY NOTE
 THIS DOCUMENT CONTAINS INFORMATION CONFIDENTIAL AND PROPRIETARY TO SAMTEC, INC. AND SHALL NOT BE REPRODUCED OR TRANSFERRED TO OTHER DOCUMENTS OR DISCLOSED TO OTHERS OR USED FOR ANY PURPOSE OTHER THAN THAT WHICH IT WAS OBTAINED WITHOUT THE EXPRESSED WRITTEN CONSENT OF SAMTEC, INC.

samtec
 520 PARK EAST BLVD, NEW ALBANY, IN 47150
 PHONE: 812-944-6733 FAX: 812-948-5047
 e-Mail: info@SAMTEC.com code 53322

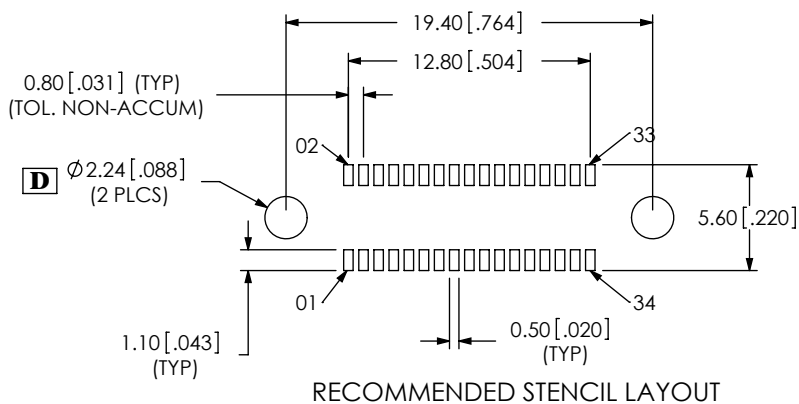
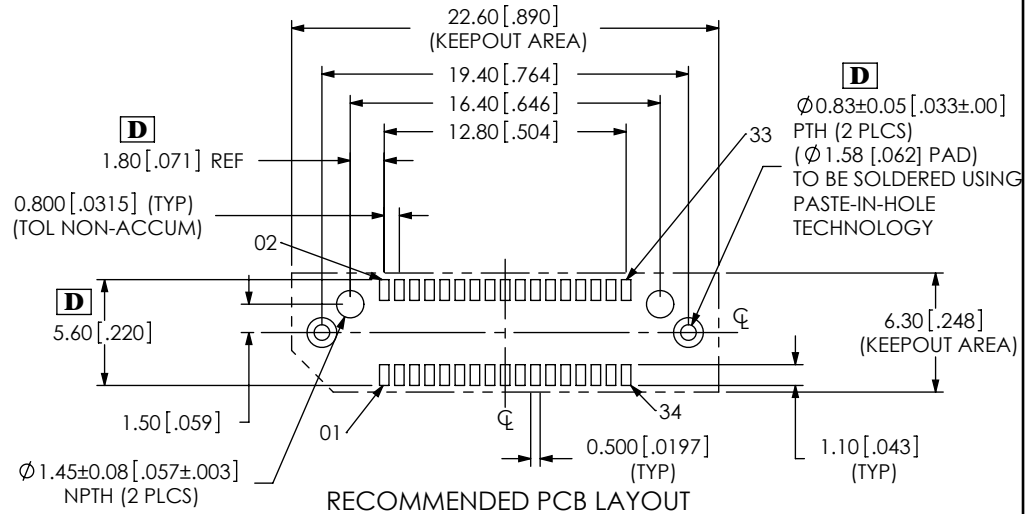
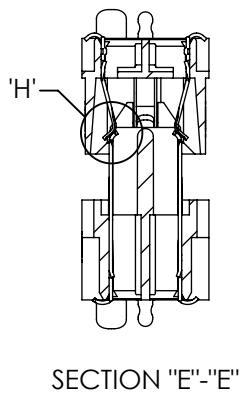
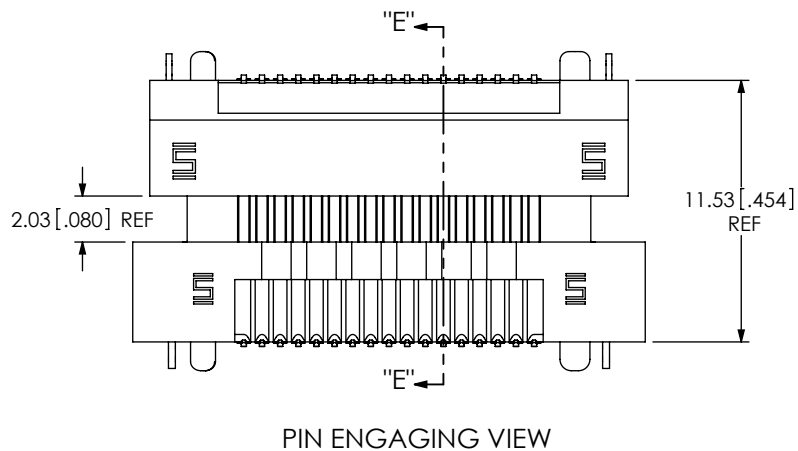
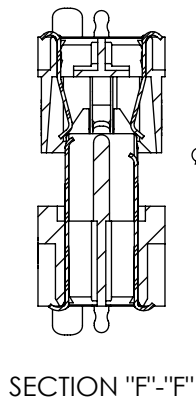
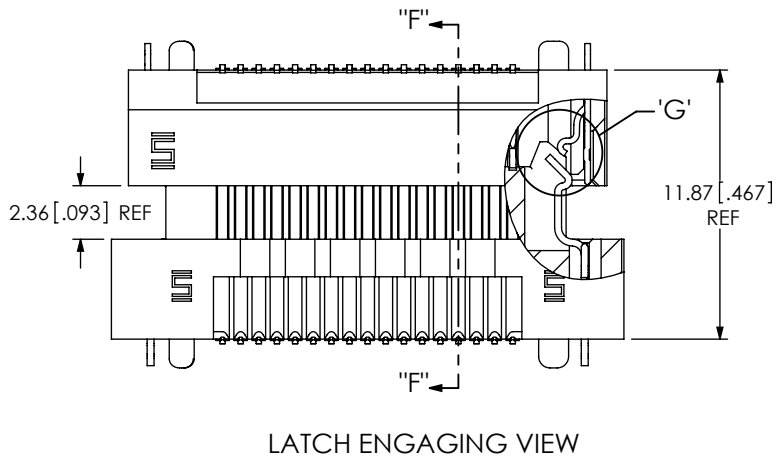

PROPRIETARY NOTE
THIS DOCUMENT CONTAINS INFORMATION CONFIDENTIAL AND PROPRIETARY TO SAMTEC, INC. AND SHALL NOT BE REPRODUCED OR TRANSFERRED TO OTHER DOCUMENTS OR DISCLOSED TO OTHERS OR USED FOR ANY PURPOSE OTHER THAN THAT WHICH IT WAS OBTAINED WITHOUT THE EXPRESSED WRITTEN CONSENT OF SAMTEC, INC.

samtec

520 PARK EAST BLVD., NEW ALBANY, IN 47150
PHONE: 812-944-6733 FAX: 812-948-5047
e-Mail info@SAMTEC.com code 53322

SHEET SCALE: 3:1

DESCRIPTION: MODIFIED ERF8 ASSEMBLY

DWG. NO. ASP-137973-01

BY: David F 01/24/2008 SHEET 2 OF 2