



AK4522

20Bit Stereo $\Delta\Sigma$ ADC & DAC

GENERAL DESCRIPTION

The AK4522 has a dynamic range of 100dB and is well-suited middle-range MD, surround system, musical instruments and car audio. Signal inputs and outputs are single-ended. The DAC outputs are analog filtered to remove out of band noise. External components are minimized. The AK4522 is available in a small 24pin SSOP package, which will reduce system space.

FEATURES

- $\Delta\Sigma$ Stereo ADC
 - 64x Oversampling
 - Sampling Rate Ranging from 16kHz to 48kHz
 - S/(N+D): 92dB
 - Dynamic Range, S/N: 100dB
 - Digital HPF for offset cancellation
- $\Delta\Sigma$ Stereo DAC
 - 128x Oversampling
 - Sampling Rate Ranging from 16kHz to 48kHz
 - 2nd order SCF + 2nd order CTF
 - Digital de-emphasis for 32kHz, 44.1kHz, 48kHz sampling
 - S/(N+D): 90dB
 - Dynamic Range, S/N: 100dB
 - Soft Mute
- High Jitter Tolerance
- Master Clock: 256fs, 384fs, 512fs
- Analog Power Supply: 4.5 to 5.5V, Digital Power Supply: 2.7 to 5.5V
- Small SSOP Package: 24pin SSOP

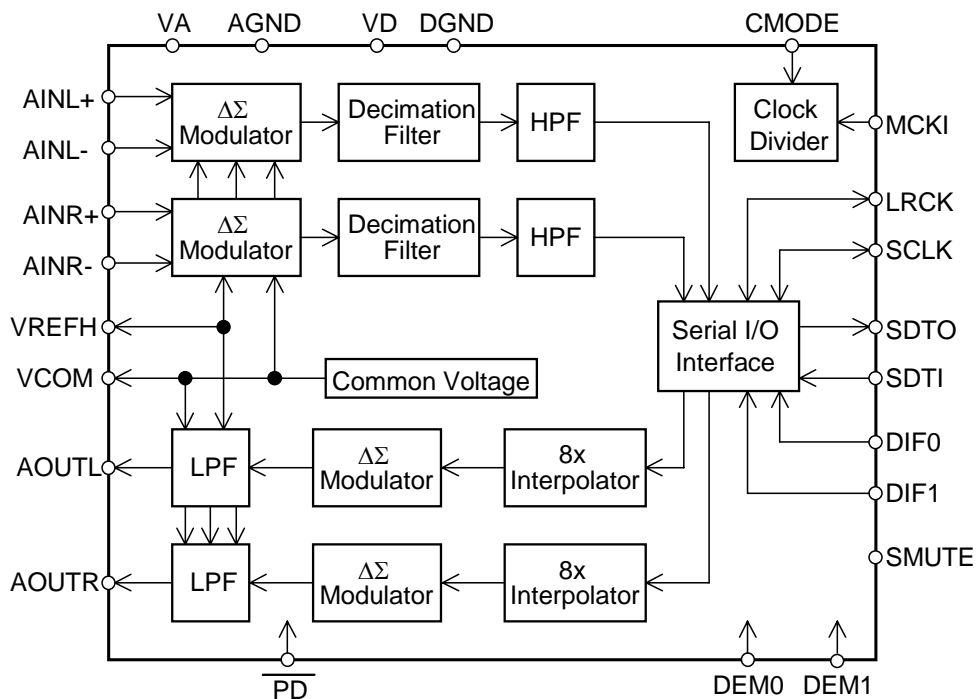

■ Ordering Guide

AK4522VM

-10 ~ +70°C

24pin SSOP (0.65mm pitch)

■ Pin Layout

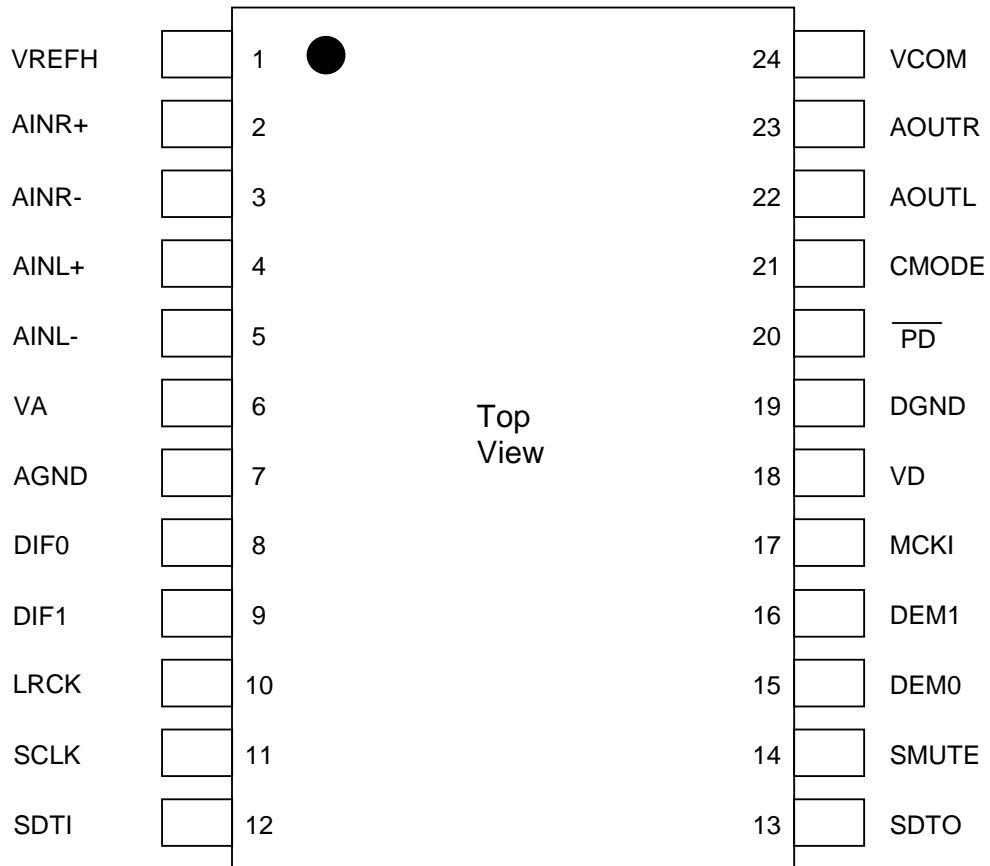

PIN/FUNCTION			
No.	Pin Name	I/O	Function
1	VREFH	I	Positive Voltage Reference Input Pin, VA Used as a positive voltage reference by ADC & DAC. VREFH should be connected externally to filtered VA.
2	AINR+	I	Rch Analog Positive Input Pin
3	AINR-	I	Rch Analog Negative Input Pin
4	AINL+	I	Lch Analog Positive Input Pin
5	AINL-	I	Lch Analog Negative Input Pin
6	VA	-	Analog Power Supply Pin
7	AGND	-	Analog Ground Pin
8	DIF0	I	Audio Data Interface Format Pin
9	DIF1	I	Audio Data Interface Format Pin
10	LRCK	I	Input/Output Channel Clock Pin
11	SCLK	I	Audio Serial Data Clock Pin
12	SDTI	I	Audio Serial Data Input Pin
13	SDTO	O	Audio Serial Data Output Pin
14	SMUTE	I	Soft Mute Pin When this pin goes "H", soft mute cycle is initiated. When returning "L", the output mute releases.
15	DEM0	I	De-emphasis Frequency Select Pin
16	DEM1	I	De-emphasis Frequency Select Pin
17	MCKI	I	Master Clock Input/X'tal Input Pin
18	VD	-	Digital Power Supply Pin
19	DGND	-	Digital Ground Pin
20	$\overline{\text{PD}}$	I	Reset Pin
21	CMODE	I	Master Clock Select Pin "H": 384fs, "L": 256fs, "NC": 512fs (Internal Biased pin)
22	AOUTL	I	Lch Analog Output Pin
23	AOUTR	I	Rch Analog Output Pin
24	VCOM	O	Common Voltage Output Pin, VA/2

Note: All input pins except pull-down pins should not be left floating.

ABSOLUTE MAXIMUM RATINGS

(AGND DGND=0V; Note 1)

Parameter		Symbol	min	max	Units
Power Supplies	Analog	VA	-0.3	6.0	V
	Digital	VD	-0.3	6.0	V
	AGND-DGND (Note 2)	Δ GND	-	0.3	V
Input Current, Any Pin Except Supplies		IIN	-	\pm 10	mA
Analog Input Voltage		VINA	-0.3	VA+0.3	V
Digital Input Voltage		VIND	-0.3	VD+0.3	V
Ambient Temperature (power applied)		Ta	-10	70	°C
Storage Temperature		Tstg	-65	150	°C

Note: 1. All voltages with respect to ground.
 2. AGND and DGND must be same voltage.

WARNING: Operation at or beyond these limits may result in permanent damage to the device.
 Normal operation is not guaranteed at these extremes.

RECOMMENDED OPERATING CONDITIONS

(AGND, DGND=0V; Note 1)

Parameter		Symbol	min	typ	max	Units
Power Supplies (Note 3)	Analog	VA	4.5	5.0	5.5	V
	Digital	VD	2.7	5.0	VA	V

Note: 1. All voltages with respect to ground.
 3. The power up sequence between VA and VD is not critical.

*AKM assumes no responsibility for the usage beyond the conditions in this datasheet.

ANALOG CHARACTERISTICS

(Ta=25°C; VA, VD=5V; AGND, DGND=0V; VREFH=VA; fs=44.1kHz; SCLK=64fs;

Signal Frequency =1kHz; 20bit Data; Measurement Frequency=10Hz ~ 20kHz; unless otherwise specified)

Parameter	min	typ	max	Units
ADC Analog Input Characteristics: Differential Inputs; Analog Source Impedance=470Ω				
Resolution			20	Bits
S/(N+D) (-0.5dB Input) (Note 4)	84	92		dB
DR (-60dB Input, A-Weighted) (Note 5)	94	100		dB
S/N (A-Weighted) (Note 5, 6)	94	100		dB
Interchannel Isolation	90	110		dB
Interchannel Gain Mismatch		0.1	0.3	dB
Gain Drift		20		ppm/°C
Input Voltage (AIN=0.6 x VREFH) (Note 7)	2.85	3.0	3.15	Vpp
Input Resistance	20	30		kΩ
Power Supply Rejection (Note 8)		50		dB
DAC Analog Output Characteristics:				
Resolution			20	Bits
S/(N+D)	80	90		dB
DR (-60dB Output, A-Weighted) (Note 5)	95	100		dB
S/N (A-Weighted) (Note 6, 9)	95	100		dB
Interchannel Isolation	90	110		dB
Interchannel Gain Mismatch		0.2	0.5	dB
Gain Drift		20		ppm/°C
Output Voltage (AOUT=0.6 x VREFH)	2.65	2.9	3.15	Vpp
Load Resistance	5			kΩ
Load Capacitance			25	pF
Power Supply Rejection (Note 8)		50		dB
Power Supplies				
Power Supply Current (VA=VD=5V)				
Analog, VA PD ="H"		42	55	mA
Digital, VD PD ="H"		10	20	mA

Note: 4. In case of single ended input, S/(N+D)=80dB(typ, @VA=5V).

5. In case of 16bit, DR and S/N of ADC are 98dB. DR of DAC is 98dB.

6. S/N measured by CCIR-ARM is 96dB at each converter and 94dB at ADC to DAC loopback.

7. Full scale input for each AIN+/- pin is 1.5Vpp in differential mode.

8. PSR is applied to VA, VD with 1kHz, 50mVpp. VREFH pin is held a constant voltage.

9. As the input data is "0", S/N is 100dB regardless of resolution.

FILTER CHARACTERISTICS

(Ta=25°C; VA=4.5 ~ 5.5V, VD=2.7 ~ 5.5V; fs=44.1kHz; DEM0="1", DEM1="0")

Parameter	Symbol	min	typ	max	Units
ADC Digital Filter (Decimation LPF):					
Passband (Note 10)	-0.005dB	PB	0		19.76 kHz
	-0.02dB		0		20.02 kHz
	-0.06dB		0		20.20 kHz
	-6.0dB		0		22.05 kHz
Stopband	SB	24.34			kHz
Passband Ripple	PR			±0.005	dB
Stopband Attenuation	SA	80			dB
Group Delay (Note 11)	GD		29.3		1/fs
Group Delay Distortion	ΔGD		0		us
ADC Digital Filter (HPF):					
Frequency Response (Note 10)	-3dB	FR		0.9	Hz
	-0.5dB			2.7	Hz
	-0.1dB			6.0	Hz
DAC Digital Filter:					
Passband (Note 10)	-0.06dB	PB	0		20.0 kHz
	-6.0dB		0		22.05 kHz
Stopband	SB	24.1			kHz
Passband Ripple	PR			±0.06	dB
Stopband Attenuation	SA	43			dB
Group Delay (Note 11)	GD		14.7		1/fs
DAC Digital Filter + Analog Filter:					
Frequency Response:	0 ~ 20.0kHz	FR		±0.2	dB

Note: 10. The passband and stopband frequencies scale with fs.

For example, 20.02kHz at -0.02dB is 0.454 x fs. The reference frequency of these responses is 1kHz.

11. The calculating delay time which occurred by digital filtering. This time is from the input of analog signal to setting the 20bit data of both channels to the output register for ADC.

For DAC, this time is from setting the 20bit data of both channels on input register to the output of analog signal.

DIGITAL CHARACTERISTICS

(Ta=25°C; VA=4.5 ~ 5.5V, VD=2.7 ~ 5.5V)

Parameter	Symbol	min	typ	Max	Units
High-Level Input Voltage (Except CMODE pin)	VIH	70% VD	-	-	V
	VIL	-	-	30% VD	V
Low-Level Input Voltage (Except CMODE pin)	VIH	95% VD	-	-	V
	VIL	-	-	10% VD	V
High-Level Output Voltage (Iout=-80uA)	VOH	VD-0.4	-	-	V
Low-Level Output Voltage (Iout=80uA)	VOL	-	-	0.4	V
Input Leakage Current (Note 12)	Iin	-	-	±10	uA

Note: 12. CMODE pin has internal pull-up and pull-down devices, nominally 50kohm.

SWITCHING CHARACTERISTICS

(Ta=25°C; VA=4.5 ~ 5.5V, VD=2.7 ~ 5.5V; CL=20pF)

Parameter	Symbol	min	typ	max	Units	
Master Clock Timing						
External Clock	256fs:	fCLK	4.096		12.288	MHz
	Pulse Width Low	tCLKL	27			ns
	Pulse Width High	tCLKH	27			ns
	384fs:	fCLK	6.144		18.432	MHz
	Pulse Width Low	tCLKL	20			ns
	Pulse Width High	tCLKH	20			ns
	512fs:	fCLK	8.192		24.576	MHz
	Pulse Width Low	tCLKL	15			ns
	Pulse Width High	tCLKH	15			ns
LRCK						
Frequency	f _{sn}	16	44.1	48	kHz	
Duty Cycle	d _{fs}	45		55	%	
Serial Interface Timing						
Slave mode						
SCLK Period	tSCK	160			ns	
SCLK Pulse Width Low	tSCKL	65			ns	
Pulse Width High	tSCKH	65			ns	
LRCK Edge to SCLK “↑” (Note 13)	tLRS	45			ns	
SCLK “↑” to LRCK Edge (Note 13)	tSLR	45			ns	
LRCK to SDTO(MSB)	tLRM			40	ns	
SCLK “↓” to SDTO	tSSD			50	ns	
SDTI Hold Time	tSDH	40			ns	
SDTI Setup Time	tSDS	25			ns	
Reset Timing						
$\overline{\text{PD}}$ Pulse Width	tPD	150			ns	
$\overline{\text{PD}}$ “↑” to SDTO valid (Note 14)	tPDV		516		1/fs	

Note 13. SCLK rising edge must not occur at the same time as $\overline{\text{LRCK}}$ edge.

14. These cycles are the number of $\overline{\text{LRCK}}$ rising from $\overline{\text{PD}}$ rising.

The AK4522 can be reset by bringing $\overline{\text{PD}}$ “L”.

■ Timing Diagram

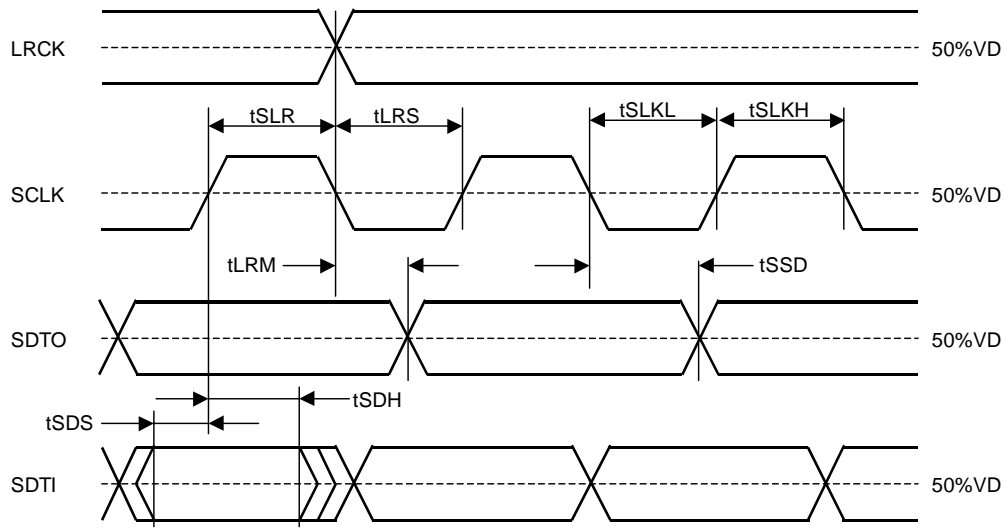

Serial Interface Timing (Slave mode)

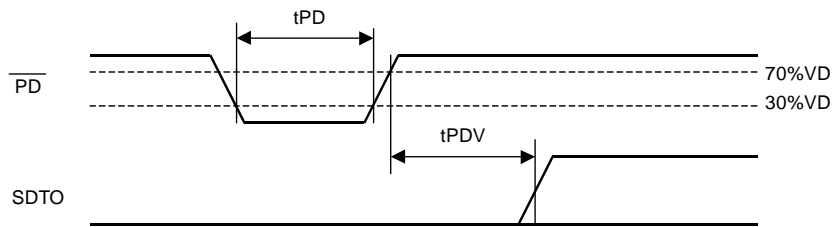

Reset & Initialize Timing

OPERATION OVERVIEW

■ **System Clock**

The master clock (MCLK) can be external clock input to the MCKI pin. CMODE is used to select either MCLK=256fs, 384fs or 512fs. The relationship between the MCLK and the desired sample rate is defined in Table 1. The LRCK clock input must be synchronized with MCLK, however the phase is not critical. Internal timing is synchronized to LRCK upon power-up. All external clocks must be present unless PD = "L", otherwise excessive current may result from abnormal operation of internal dynamic logic.

fs	MCLK			SCLK	
	256fs CMODE="L"	384fs CMODE="H"	512fs CMODE="NC"	64fs	128fs
32.0kHz	8.1920MHz	12.2880MHz	16.384MHz	2.048MHz	4.096MHz
44.1kHz	11.2896MHz	16.9344MHz	22.579MHz	2.822MHz	5.644MHz
48.0kHz	12.2880MHz	18.4320MHz	24.576MHz	3.072MHz	6.144MHz

Table 1. System Clock Example

■ **Audio Serial Interface Format**

Data is shifted in/out the SDTI/SDTO pins using SCLK and LRCK inputs. Four serial data modes selected by the DIF0 and DIF1 pins are supported as shown in Table 2. In all modes the serial data has MSB first, 2's compliment format. The data is clocked out on the falling edge of SCLK and latched on the rising edge. For mode 3, if SCLK is 32fs, then the least significant bits will be truncated.

Mode	DIF1	DIF0	SDTO (ADC)	SDTI (DAC)	L/R	SCLK
0	0	0	20bit, MSB justified	16bit, LSB justified	H/L	≥ 32fs
1	0	1	20bit, MSB justified	20bit, LSB justified	H/L	≥ 40fs
2	1	0	20bit, MSB justified	20bit, MSB justified	H/L	≥ 40fs
3	1	1	IIS (I2S)	IIS (I2S)	L/H	≥ 32fs or 40fs

Table 2. Serial Data Modes

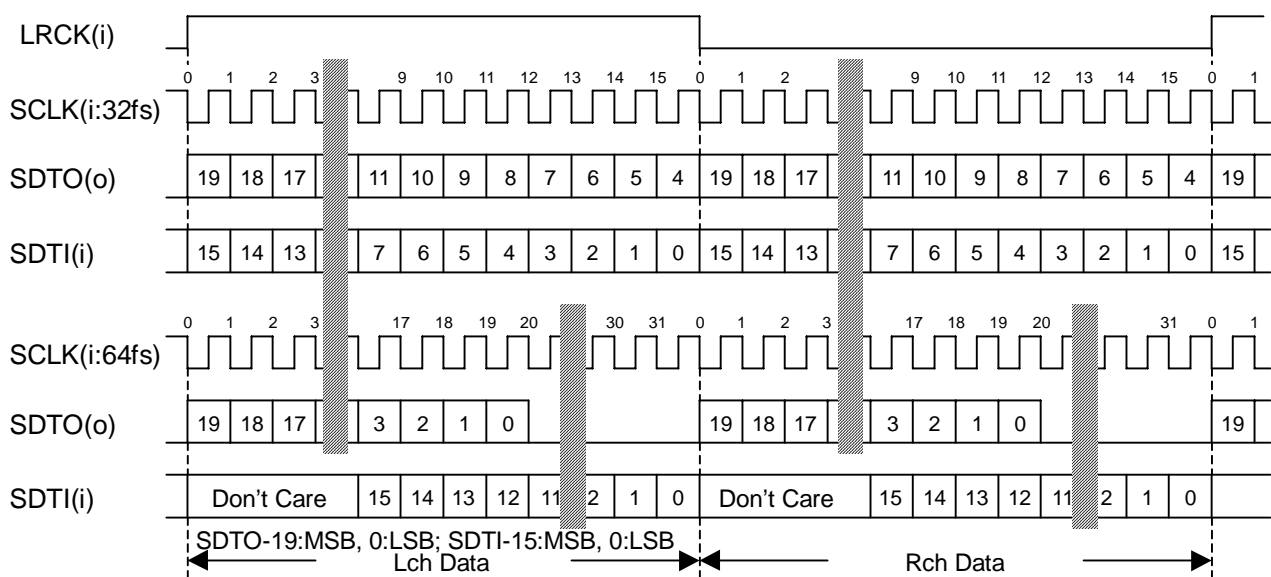

Figure 1. Mode 0 Timing

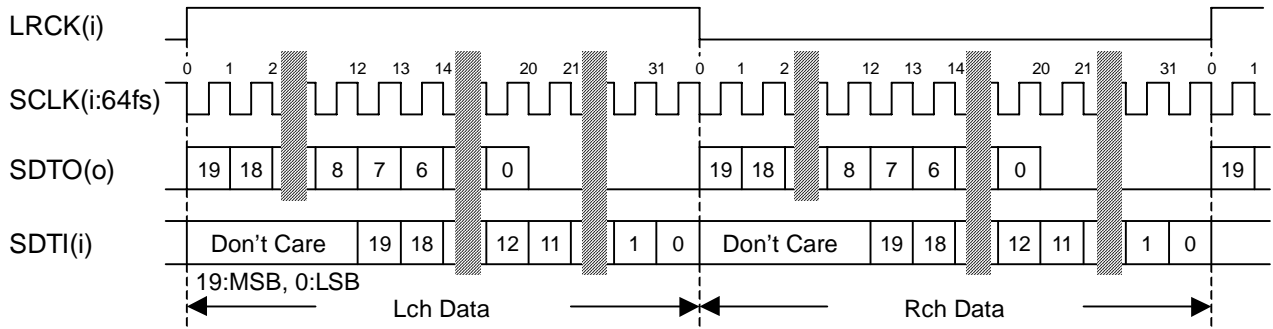

Figure 2. Mode 1 Timing

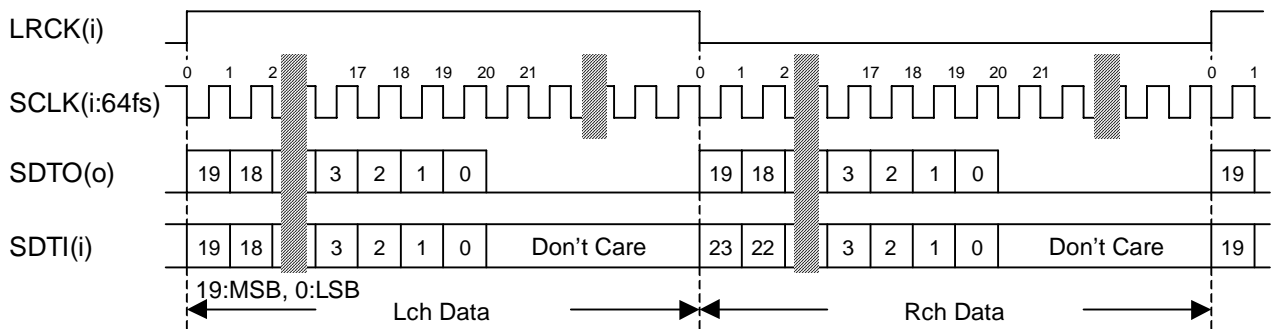

Figure 3. Mode 2 Timing

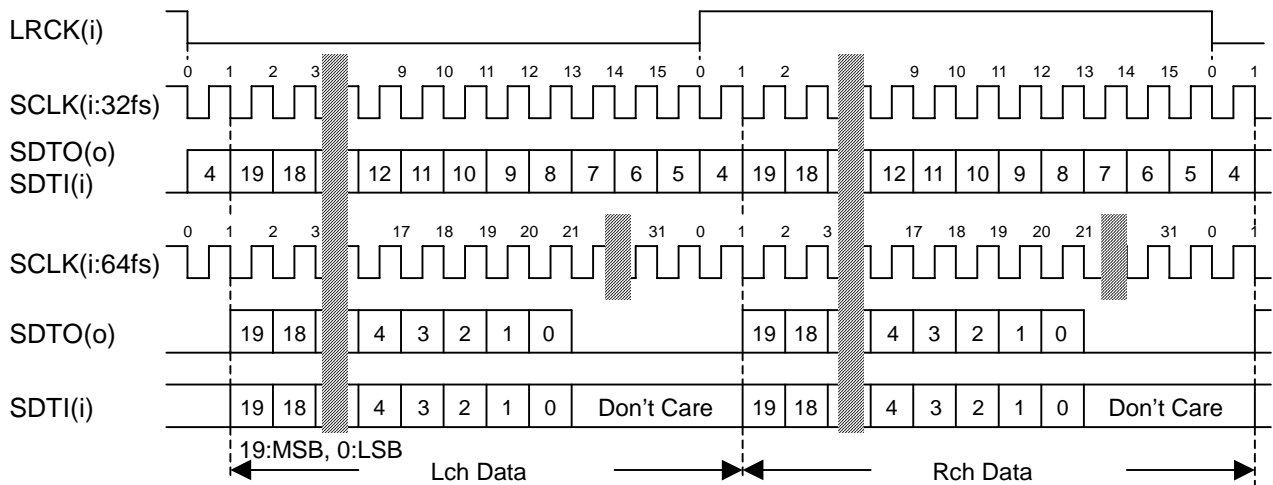

Figure 4. Mode 3 Timing

■ Digital High Pass Filter

The ADC of AK4522 has a digital high pass filter for DC offset cancel. The cut-off frequency of the HPF is 0.9Hz at $f_s=44.1\text{kHz}$ and also scales with sampling rate (fs).

■ De-emphasis Filter

The DAC of AK4522 includes the digital de-emphasis filter ($t_c=50/15\mu s$) by IIR filter. This filter corresponds to three frequencies (32kHz, 44.1kHz, 48kHz). The de-emphasis filter selected by DEM0 and DEM1 is enabled for input audio data. The de-emphasis is also disabled at DEM0="1" and DEM1="0".

DEM1	DEM0	Mode
0	0	44.1kHz
0	1	OFF
1	0	48kHz
1	1	32kHz

Table 3. De-emphasis filter control

■ Soft Mute Operation

Soft mute operation is performed at digital domain. When SMUTE goes to "H", the output signal is attenuated by $-\infty$ during 1024 LRCK cycles. When SMUTE is returned to "L", the mute is cancelled and the output attenuation gradually changes to 0dB during 1024 LRCK cycles. If the soft mute is cancelled within 1024 LRCK cycles after starting the operation, the attenuation is discontinued and returned to 0dB. The soft mute is effective for changing the signal source without stopping the signal transmission.

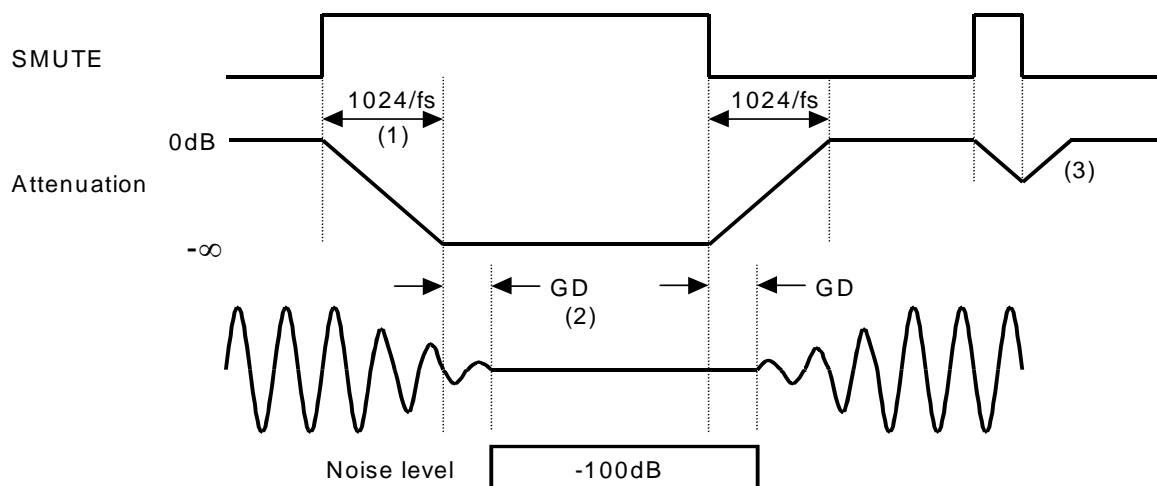

Notes:

- (1) The output signal is attenuated by $-\infty$ during 1024 LRCK cycles ($1024/f_s$).
- (2) Analog output corresponding to digital input has the group delay (GD).
- (3) If the soft mute is cancelled within 1024 LRCK cycles, the attenuation is discontinued and returned to 0dB.

Figure 5. Soft Mute Operation

■ Power-Down & Reset

The ADC and DAC of AK4522 are placed in the reset mode by bringing a reset pin, \overline{PD} “L”. This reset should always be done after power-up. In case of the ADC, an analog initialization cycle starts after exiting the reset mode. Therefore, the output data, SDTO becomes available after 516 cycles of LRCK clock. This initialization cycle does not affect the DAC operation. Figure 6 shows the power-up sequence.

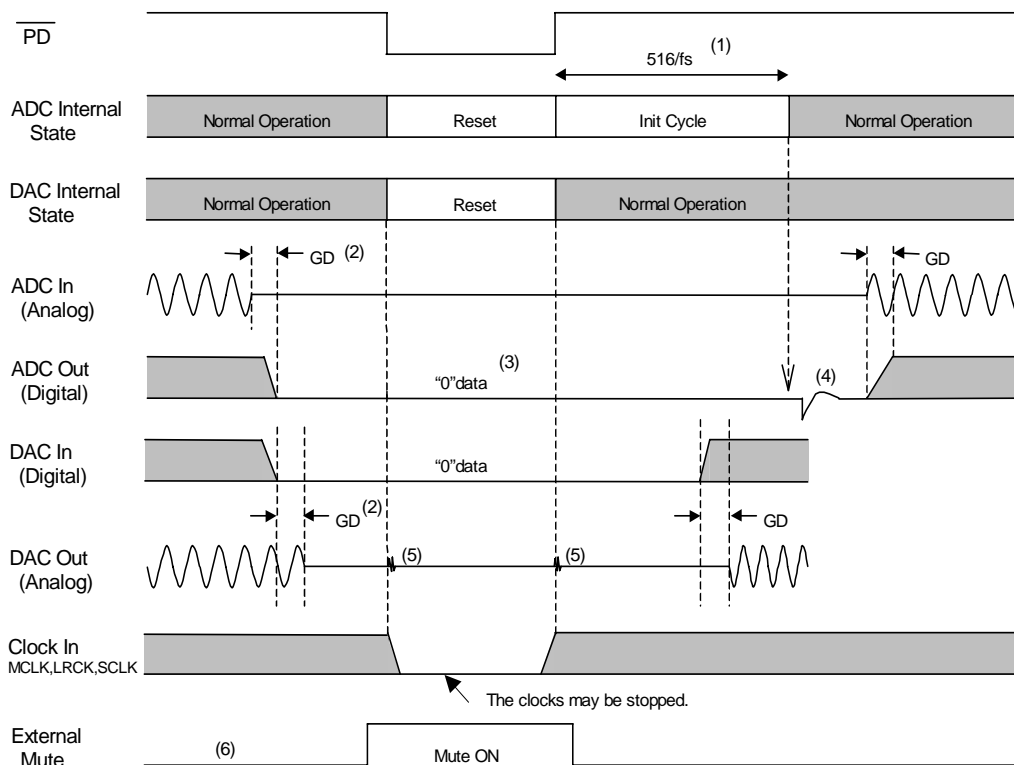

- (1) The analog part of ADC is initialized after exiting the reset state.
- (2) Digital output corresponding to analog input and analog output corresponding to digital input have the group delay (GD).
- (3) A/D output is “0” data at the reset state.
- (4) Small click noise occurs at the end of initialization of the analog part. Please mute the digital output externally if the click noise influences system application.
- (5) Click noise occurs at the edge of \overline{PD} .
- (6) Please mute the analog output externally if the click noise (5) influences system application.

Figure 6. Power-up sequence

SYSTEM DESIGN

Figure 7 shows the system connection diagram. This is an example which analog signal is input by single ended circuit. In case of differential input, please refer to Figure 10. An evaluation board is available which demonstrates application circuits, the optimum layout, power supply arrangements and measurement results.

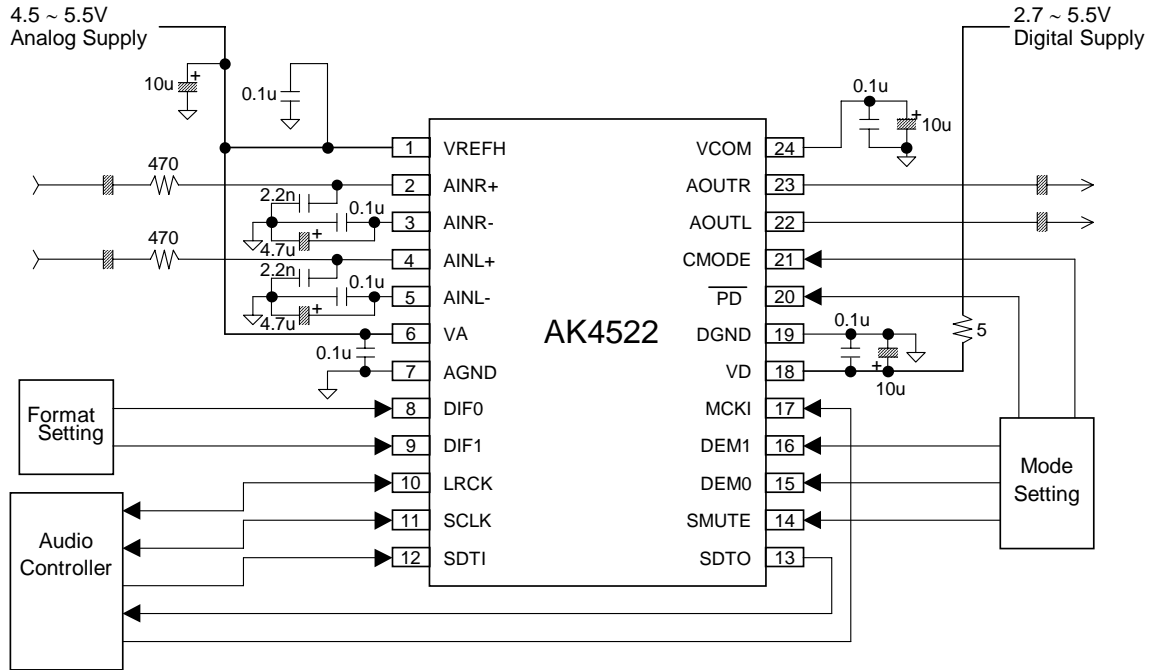

Figure 7. Typical Connection Diagram

Notes:

- When AOUT drives some capacitive load, some resistor should be added in series between AOUT and capacitive load.
- All input pins except CMODE pin should not be left floating.

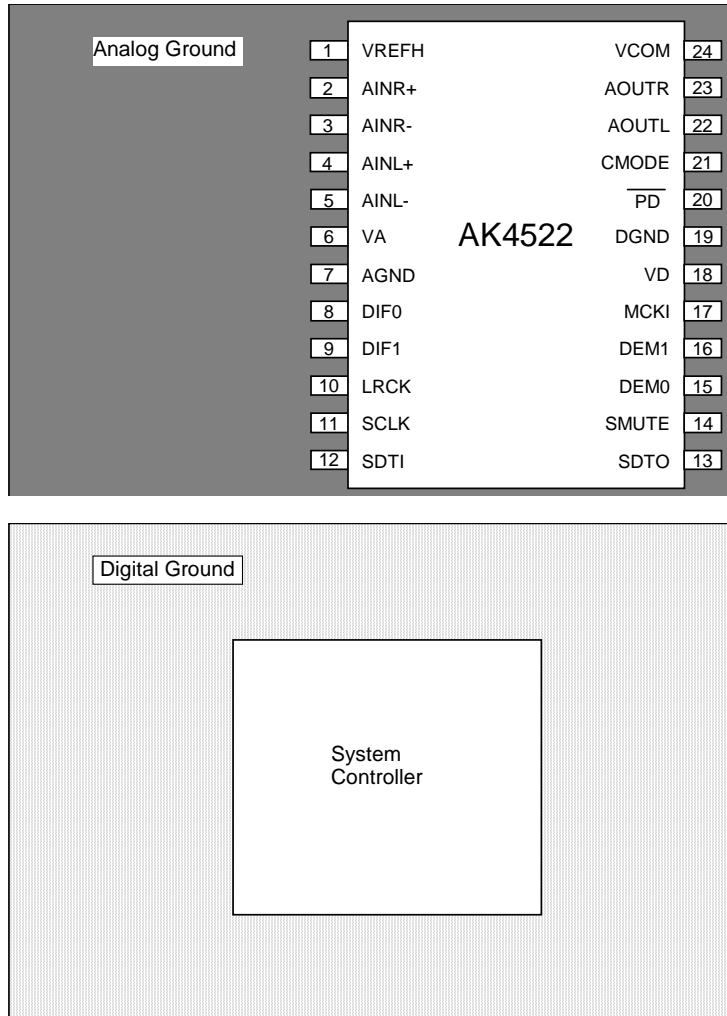

Figure 8. Ground Layout

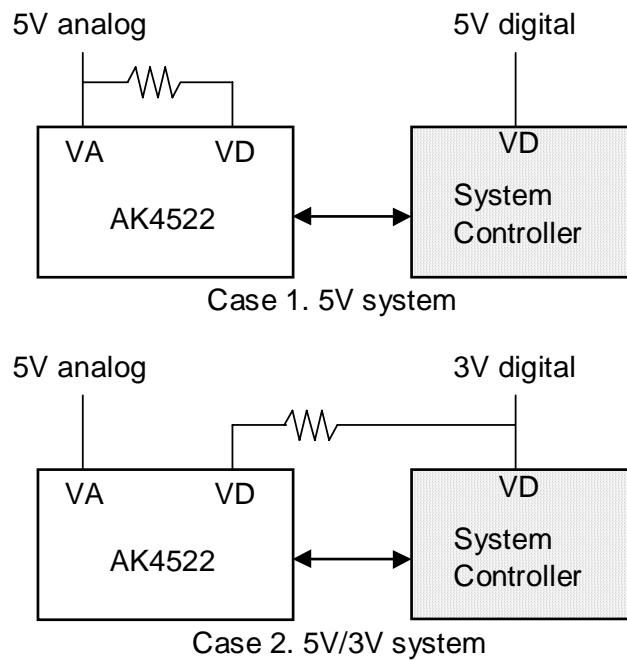

Figure 9. Power Supply Arrangement

1. Grounding and Power Supply Decoupling

The AK4522 requires careful attention to power supply and grounding arrangements. VA and VD are usually supplied from analog supply in system. Alternatively if VA and VD are supplied separately, the power up sequence is not critical. AGND and DGND of the AK4522 should be connected to analog ground plane. System analog ground and digital ground should be connected together near to where the supplies are brought onto the printed circuit board. Decoupling capacitors should be as near to the AK4522 as possible, with the small value ceramic capacitor being the nearest.

2. Voltage Reference

The differential voltage between VREFH and AGND sets the analog input/output range. VREFH pin is normally connected to VA with a 0.1uF ceramic capacitor. VCOM is a signal ground of this chip. An electrolytic capacitor 10uF parallel with a 0.1uF ceramic capacitor attached to VCOM pin eliminates the effects of high frequency noise. No load current may be drawn from VCOM pin. All signals, especially clocks, should be kept away from the VREFH and VCOM pins in order to avoid unwanted coupling into the AK4522.

3. Analog Inputs

The ADC inputs are differential and internally biased to the common voltage (VA/2) with 30kΩ (typ) resistance. Figure 7 is a circuit example which analog signal is input by single end. The signal can be input from either positive or negative input and the input signal range scales with the supply voltage and nominally 0.6 x VREFH Vpp. In case of single ended input, the distortion around full scale degrades compared with differential input. Figure 10 is a circuit example which analog signal is input to both positive and negative input and the input signal range scales with the supply voltage and nominally 0.3 x VREFH Vpp. The AK4522 can accept input voltages from AGND to VA. The ADC output data format is 2's complement. The output code is 7FFFFH (@20bit) for input above a positive full scale and 80000H (@20bit) for input below a negative full scale. The ideal code is 00000H (@20bit) with no input signal. The DC offset is removed by the internal HPF.

The AK4522 samples the analog inputs at 64fs. The digital filter rejects noise above the stop band except for multiples of 64fs. A simple RC filter (fc=150kHz) may be used to attenuate any noise around 64fs and most audio signals do not have significant energy at 64fs.

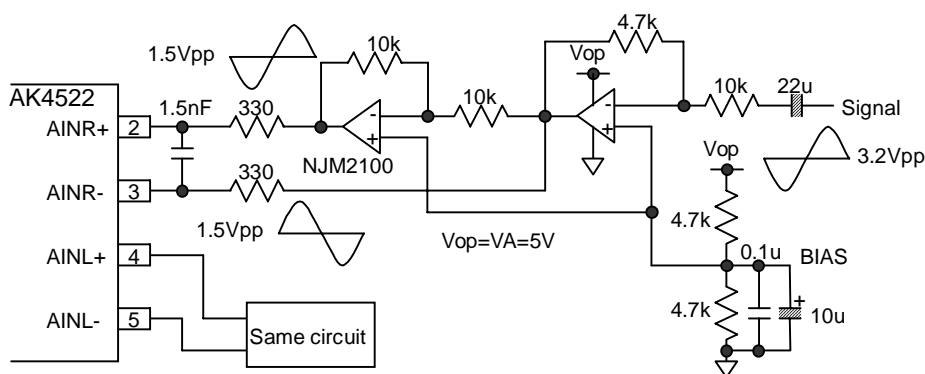

Figure 10. Differential Input Buffer Example

4. Analog Outputs

The analog outputs are also single-ended and centered around the VCOM voltage. The input signal range scales with the supply voltage and nominally $0.58 \times V_{REFH} V_{pp}$. The DAC input data format is 2's complement. The output voltage is a positive full scale for 7FFFFH(@20bit) and a negative full scale for 80000H(@20bit). The ideal output is VCOM voltage for 00000H(@20bit). The internal switched-capacitor filter and continuous-time filter remove most of the noise generated by the delta-sigma modulator of DAC beyond the audio passband.

DC offsets on analog outputs are eliminated by AC coupling since DAC outputs have DC offsets of a few mV. Figure 11 shows the example of external op-amp circuit with 6dB gain. The output signal is inverted by using the circuit in this case.

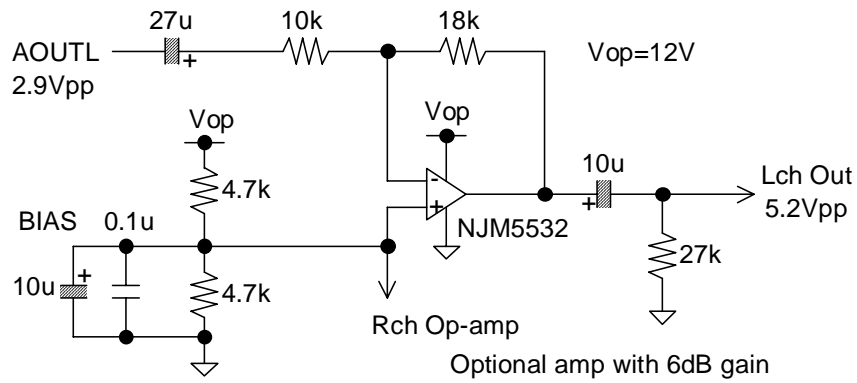
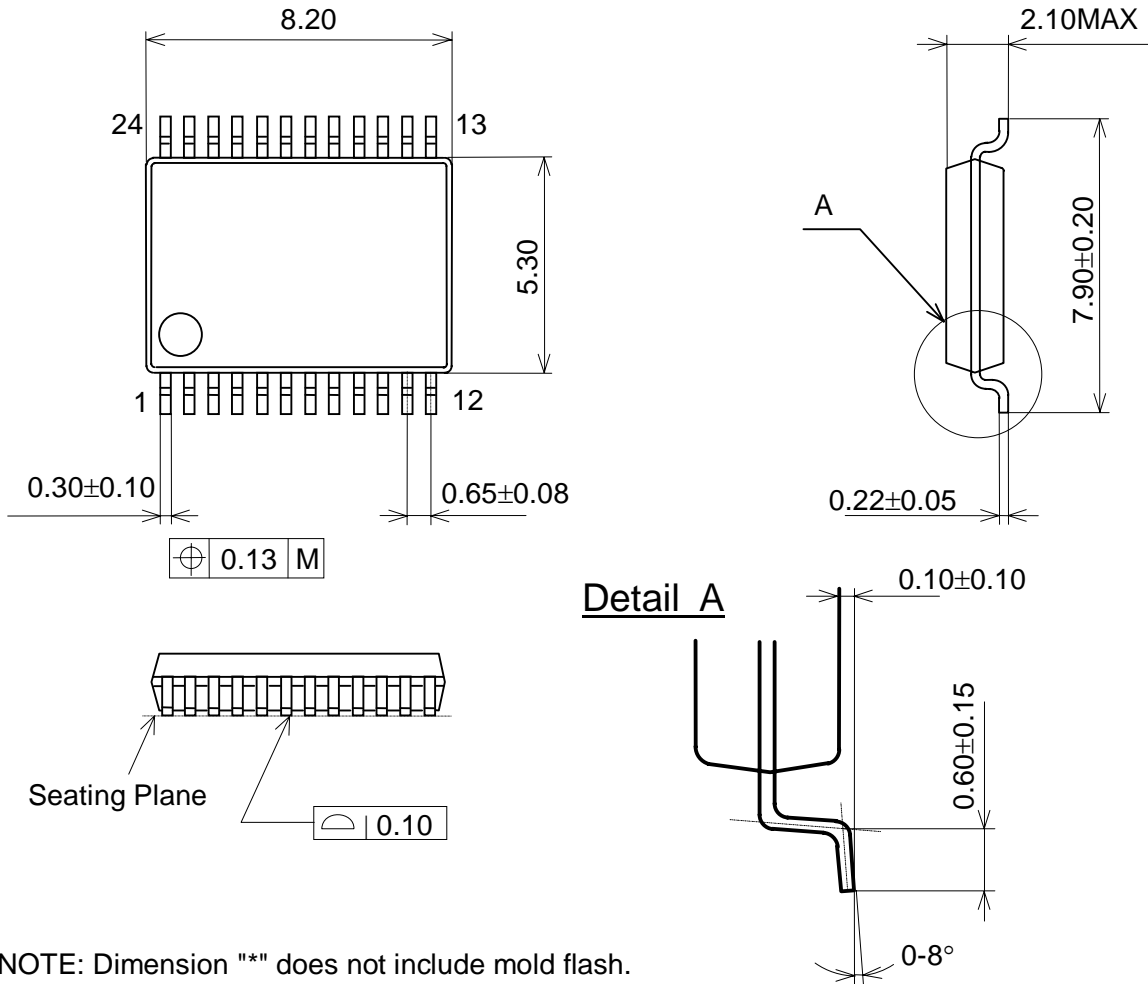

Figure 11. External analog circuit example (gain=6dB)

PACKAGE

24pin SSOP (Unit: mm)



NOTE: Dimension "*" does not include mold flash.

■ Package & Lead frame material

- Package molding compound: Epoxy
- Lead frame material: Cu
- Lead frame surface treatment: Solder plate

MARKING

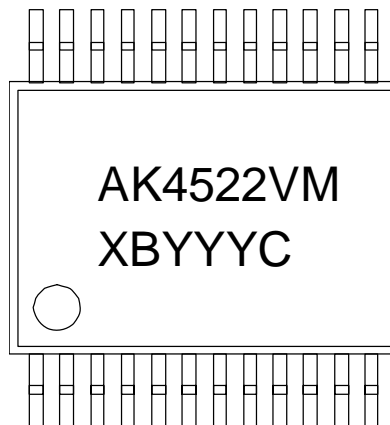

XBYYC: Date code identifier

XB: Lot number (X: Digit number, B: Alpha character)

YYC: Assembly date (Y: Digit number, C: Alpha character)

REVISION HISTORY

Date (Y/M/D)	Revision	Reason	Page	Contents
12/01/25	02	Specification Change	1, 2, 17, 18	AK4522VF was deleted. (24pin VSOP) AK4522VM was added. (24pin SSOP) Ordering Guide was changed. PACKAGE was changed. MARKING was changed.

IMPORTANT NOTICE

- These products and their specifications are subject to change without notice.
When you consider any use or application of these products, please make inquiries the sales office of Asahi Kasei Microdevices Corporation (AKM) or authorized distributors as to current status of the products.
- Descriptions of external circuits, application circuits, software and other related information contained in this document are provided only to illustrate the operation and application examples of the semiconductor products. You are fully responsible for the incorporation of these external circuits, application circuits, software and other related information in the design of your equipments. AKM assumes no responsibility for any losses incurred by you or third parties arising from the use of these information herein. AKM assumes no liability for infringement of any patent, intellectual property, or other rights in the application or use of such information contained herein.
- Any export of these products, or devices or systems containing them, may require an export license or other official approval under the law and regulations of the country of export pertaining to customs and tariffs, currency exchange, or strategic materials.
- AKM products are neither intended nor authorized for use as critical components^{Note1)} in any safety, life support, or other hazard related device or system^{Note2)}, and AKM assumes no responsibility for such use, except for the use approved with the express written consent by Representative Director of AKM. As used here:
 - Note1) A critical component is one whose failure to function or perform may reasonably be expected to result, whether directly or indirectly, in the loss of the safety or effectiveness of the device or system containing it, and which must therefore meet very high standards of performance and reliability.
 - Note2) A hazard related device or system is one designed or intended for life support or maintenance of safety or for applications in medicine, aerospace, nuclear energy, or other fields, in which its failure to function or perform may reasonably be expected to result in loss of life or in significant injury or damage to person or property.
- It is the responsibility of the buyer or distributor of AKM products, who distributes, disposes of, or otherwise places the product with a third party, to notify such third party in advance of the above content and conditions, and the buyer or distributor agrees to assume any and all responsibility and liability for and hold AKM harmless from any and all claims arising from the use of said product in the absence of such notification.