

## Features

- 4dBm Output Level at 1288 MHz
- 2<sup>nd</sup> Harmonic: <-20 -dBc
- Spurious Level: < -68dBc
- Current Consumption: < 35mA

## Description

The plerow™ PLL synthesizer module was designed for use in wireless and wireline systems in a wide range of frequency from 50 MHz to 6 GHz. ASB's PLL provides exceptionally low spurious and phase noise performance with fast locking time and low current consumption. All products are available in a surface-mount type package.

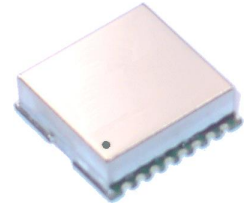

## Specifications

Parameter	Unit	Min.	Typical	Max.
Frequency Range	MHz		1288	
Output Power	dBm	2	4	6
Supply Voltage	V	4.8	5.0	5.2
Current Consumption	mA		28	35
2 <sup>nd</sup> Harmonics	dBc		-25	-20
Spurious Level	dBc		-72	-68
Reference Frequency	MHz		13	
Reference Input Level	dBm	0	2	5
Phase Noise (C / N)				
@ 1 kHz			-75	-70
@ 10 kHz	dBc/Hz		-104	-100
@ 100 kHz			-120	-115
Output Impedance	Ω		50	
Operating Temp. Range	°C	-30	25	80
Package Type & Size	mm	SMT, 19.0W×19.0L×5.8H		

1) Measurement conditions are as follows: T = 25°C, V<sub>CC</sub> = 5 V, Freq. = 1288MHz, 50 ohm system.

2) Frequency stability of internal ref. TCXO is +/- 2.5 ppm (max.) over the operating temperature range.

## More Information

Website: [www.asb.co.kr](http://www.asb.co.kr)  
E-mail: [sales@asb.co.kr](mailto:sales@asb.co.kr)

Tel: (82) 42-528-7220  
Fax: (82) 42-528-7222

ASB Inc., 4th Fl. Venture Town Bldg., 367-17 Goijeong-Dong, Seo-Gu, Daejeon 302-716, Korea

Outline Drawing

APL0000-R/T Type

Type	Dimension
PLL IC + VCO + ROM + TCXO	19 x 19 x 5.8

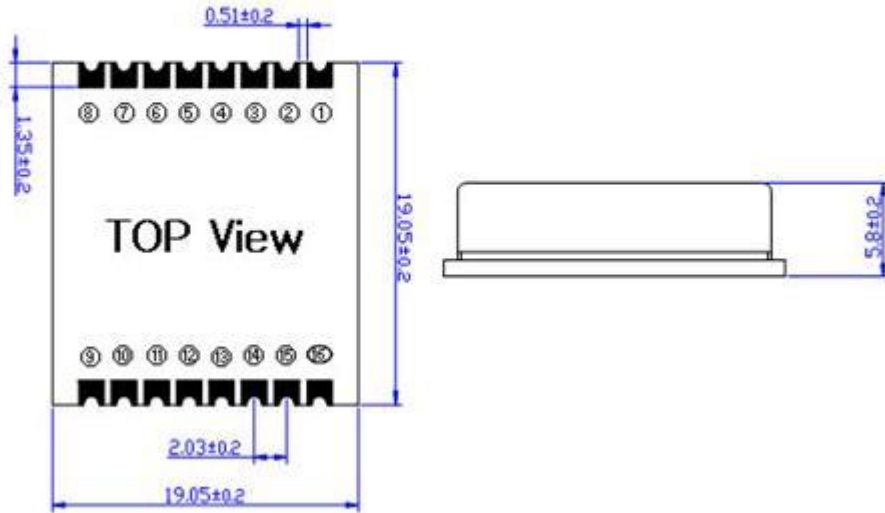

Pin Out for PLL			
Pin No.	Application	Pin No.	Application
1	GROUND	9	VCC (VCO)
2	GROUND	13	RF OUT
3	GROUND	15	VCC (PLL)
4	GROUND	16	LOCK DETECT
All other Pins are Grounded / Internal TCXO and ROM			

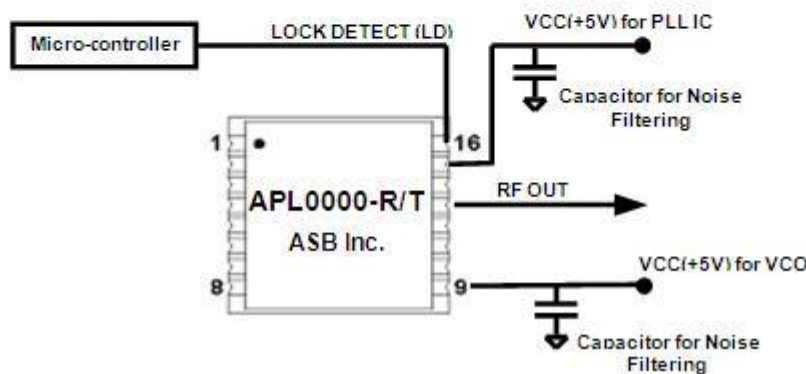

Copyright ©2006-2017 ASB Inc. All rights reserved. Datasheet subject to change without notice. ASB assumes no responsibility for any errors which may appear in this datasheet. No part of the datasheet may be copied or reproduced in any form or by any means without the prior written consent of ASB.