

GSD

M39012/01-0503

REVISIONS

ISSUE	CHANGES
10	CN 36416 E REDRAWN ME 10/20/95
11	CN 39770 C PMC 1/31/07
12	CN 39780 C PMC 2/6/07

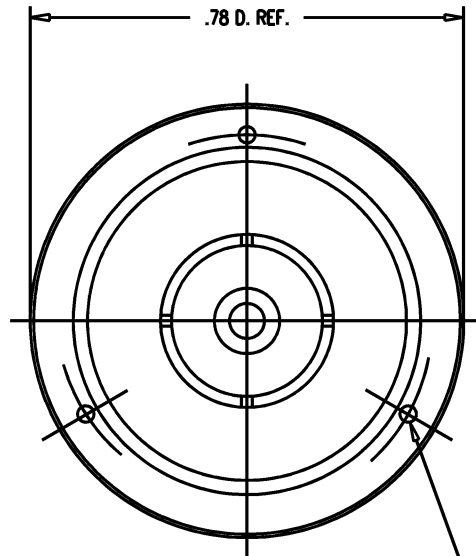
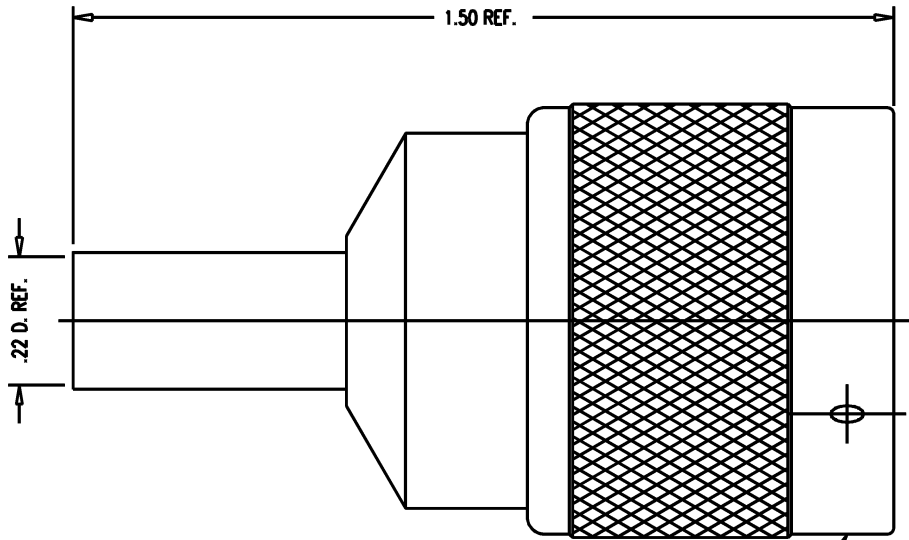

STAMP: 91836 M39012/01-0503
KN-59-242 XXXX DATE CODE)

- NOTES:**
- FOR USE WITH RG-142, 223 AND 400/U CABLE GROUPS.
 - FOR CABLING INSTRUCTIONS SEE CP-489.
 - FOR CRIMPING USE DIE KTH-2042.
 - INTERFACE PER MIL-STD-348, FIG. 304-1.
 - MATERIALS:**
INSULATOR: TEFLON, ASTM-D-4894
GASKET: SIL. RUBBER, ZZ-R-765
OUTER CONTACT AND C-RING: PHOS. BRONZE, ASTM-B-103
ALL OTHER METAL PARTS: BRASS, ASTM-B16
 - FINISHES:**
CENTER CONTACT: GOLD PLATE PER MIL-G-45204
ALL OTHER METAL PARTS: SILVER PLATE PER QQ-S-365
 - ELECTRICAL CHARACTERISTICS:**
NOMINAL IMPEDANCE: 50 ~W
FREQUENCY RANGE: DC TO 11 GHz
VOLTAGE RATING: 1000 VOLTS RMS

KN-59-242 QGS0934

SCALE : 4:1

APPROX SURFACE AREA

USED ON

REF:

PLUG, N, M

DRAWN	ME	DATE	04/02/95
DESIGN	MJB	DATE	04/02/95
APPR.		DATE	

KINGS
ELECTRONICS CO., INC.
ROCK HILL, SOUTH CAROLINA 29730

M39012/01-0503

GSD