

# Datasheet ESPP-MIT1

## Strain Gauge Pressure Transmitter

- Excellent performance at very low cost
- Micro-fused technology
- Pressure Type: Gauge
- Calibrated & temperature compensated output
- Full Scale (FS) Pressure Range: from 7 to 1000 bar
- Analog Output: 4-20mA, 05.-4.5V, 1-5V, 0-5V
- Compensation temperature: -10°C ... 80°C
- Operating temperature: -40°C ... 125°C
- Total error:  $\leq \pm 1\%FS$
- Integrated stainless steel construction, full sealed (IP65)
- Compact structure
- Wide range of process interfaces



### Product Summary

ES Systems has developed a series of pressure sensor transmitters featuring very good accuracy at low cost. Each module is based on all welded hermetically sealed structure in a single stainless-steel piece. The ESPP-MIT1 is a medium isolated pressure sensor suitable for gas or fluid pressure measurements in harsh environments.

The output is fully calibrated and temperature compensated based on the internal temperature sensor and the factory calibration coefficients which are stored in the embedded memory. Thus, the transducer is ready to be installed directly to the end user system without further processing.

ESPP-MIT1 comes with a variety of electrical interfaces output signal types and process interfaces. It is one of the most cost-effective solutions especially when high volumes are required.

### Typical Applications

- Central air conditioning control systems
- Engineering machinery
- Energy & water treatment systems
- Hydraulic & pneumatic systems
- Industrial process control & automatic detection systems
- Pumps & compressors
- Refrigeration systems

## 1. Operating Specifications

Characteristic	Min.	Typ.	Max.	Unit
Pressure Type	Gauge			-
Pressure Range	Up to 1000			bar
Power Supply ( $V_{supply}$ )	+8		+28	V
Current Consumption			4	mA
Total Error Band <sup>1</sup>	-		±1.0	%F.S. <sup>2</sup>
Operating temperature range <sup>3</sup>	-40[-40]	-	+125[257]	°C[°F]
Compensated temperature range <sup>4</sup>	-10[14]	-	80[176]	°C[°F]
Storage temperature range	-40[-40]	-	+125[257]	°C[°F]
Output	Calibrated Pressure			-
Output Interface (Out)	4-20mA, 0.5-4.5V, 1-5V, 0-5V <sup>5</sup>			-
Current Output Load Resistance	$\leq (V_{supply} - 8) / 0.02$			Ohm
Voltage Output Load Resistance	10K			Ohm
Response Time <sup>6</sup>			50	msec
Warm-up Time <sup>7</sup>			100	msec
Media Compatibility	Gases, Liquids			-
Material	Stainless Steel 17-4PH			-
IP rating	IP65			-
Certifications	CE, RoHS, REACH			-
O-ring sealing	Viton			-

<sup>1</sup> Total Error Band: The maximum deviation from ideal transfer function over the entire compensated temperature and pressure range. Includes all errors due to offset, full scale span, pressure non-linearity, pressure hysteresis, repeatability, thermal effect on offset, thermal effect on span and thermal hysteresis

<sup>2</sup> % of the full scale pressure range

<sup>3</sup> Operating temperature range: The temperature range over which the sensor will produce an output proportional to pressure

<sup>4</sup> Compensated temperature range: The temperature range over which the sensor will produce an output proportional to pressure within the specified performance limits.

<sup>5</sup> For 0-5V output,  $V_{supply}$  is +11V to +28V.

<sup>6</sup> Response Time: The time it takes for the electrical output to go from 10%FS signal to 90%FS signal and vice versa.

<sup>7</sup> Warm-up Time: Time to the first valid pressure measurement after power is applied.

## 2. Wiring Diagrams

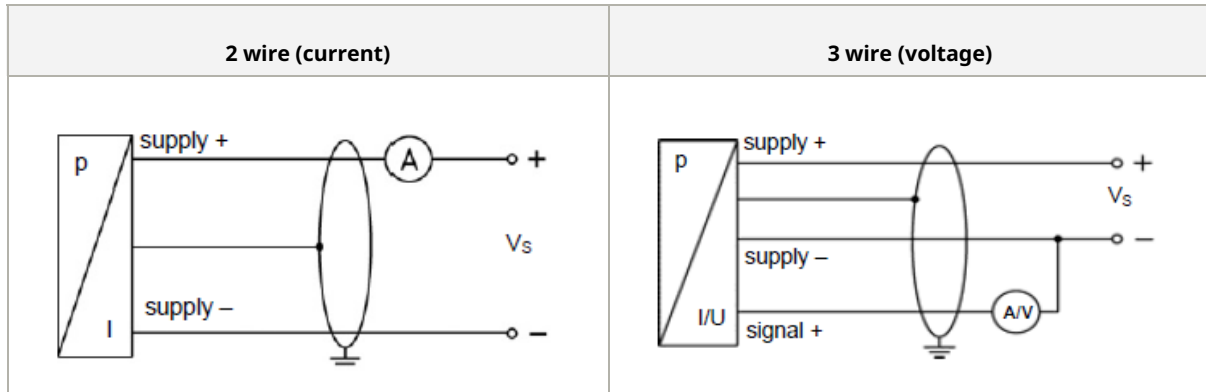



## 3. Pressure Specifications (bar)

Option	Pressure Range		Over Pressure <sup>1</sup>	Burst Pressure <sup>2</sup>
	P <sub>min</sub>	P <sub>max</sub>		
<b>0007BG</b>	0	7	14	35
<b>0010BG</b>	0	10	20	50
<b>0016BG</b>	0	16	32	80
<b>0030BG</b>	0	30	60	150
<b>0050BG</b>	0	50	100	250
<b>0100BG</b>	0	100	200	500
<b>0150BG</b>	0	150	300	750
<b>0250BG</b>	0	250	500	1250
<b>0300BG</b>	0	300	600	1500
<b>0350BG</b>	0	350	700	1750
<b>0400BG</b>	0	400	800	2000
<b>0600BG</b>	0	600	1200	2000
<b>0800BG</b>	0	800	1500	2000
<b>1000BG</b>	0	1000	1500	2000

<sup>1</sup> Overpressure: The maximum pressure which may safely be applied to the product for it to remain in specification once pressure is returned to the operating pressure range. Exposure to higher pressures may cause permanent damage to the product. Unless otherwise specified this applies to all available pressure ports at any temperature with the operating temperature range

<sup>2</sup> Burst pressure: The maximum pressure that may be applied to the specified port of the product without causing escape of pressure media. Product should not be expected to function after exposure to any pressure beyond the burst pressure

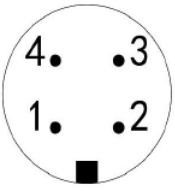
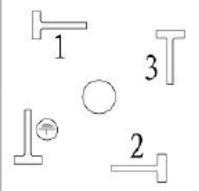
#### 4. Output Type

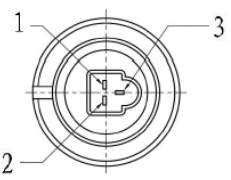
	01. M12		02. ISO4400 (Form C)		03. Cable (0.5m)		04. Packard	
								
	Current	Voltage	Current	Voltage	Current	Voltage	Current	Voltage
V <sub>supply</sub> <sup>1</sup>	1	1	1	1	Black	Black	1	1
Gnd <sup>1</sup>	-	2	-	2	-	Yellow	-	2
Out	3	3	2	3	Red	Red	3	3
Chassis	-	-	3	4	-	-	-	-

<sup>1</sup> Note that V<sub>supply</sub> & Gnd are reverse polarity protected

#### 5. Electrical Connector & Mechanical Dimensions

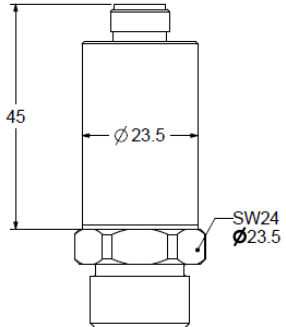
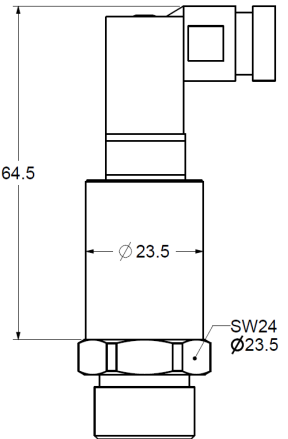
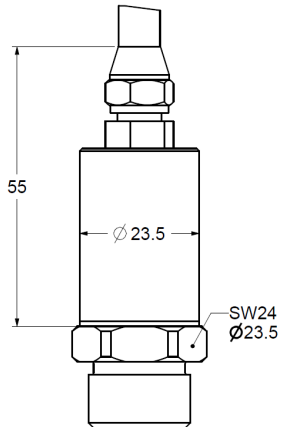
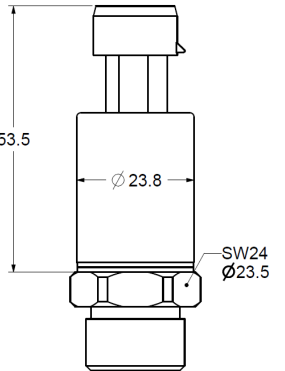
01. M12	02. ISO4400	03. Cable	04. Packard
			

<sup>1</sup> Note all dimensions are in millimeters (mm)

In order to calculate the total height of each of the options above, the height of the mechanical dimensions must be added to the height of the process interface (see section 5).

**6. Process Interface (dimensions in mm)**

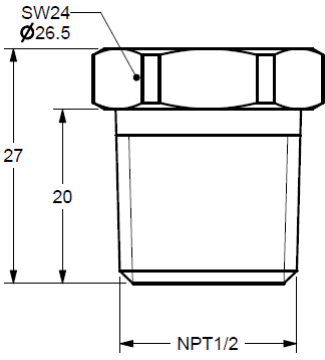
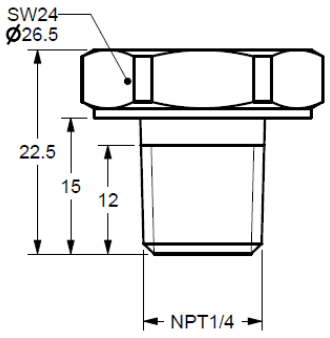
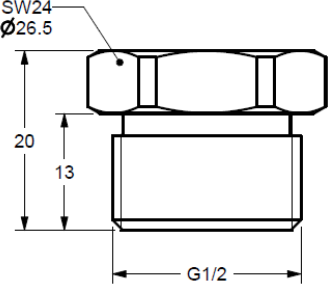
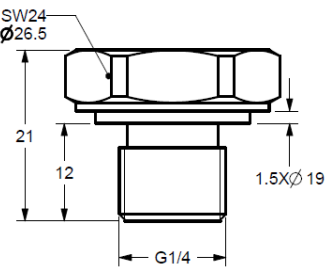
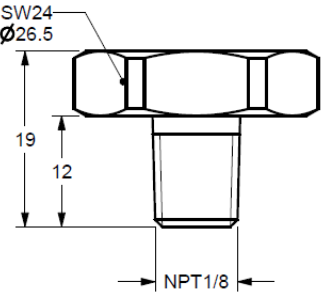
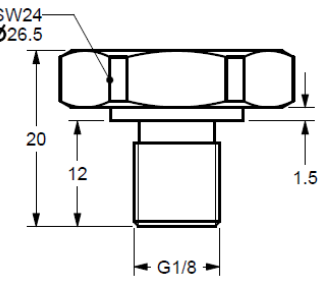
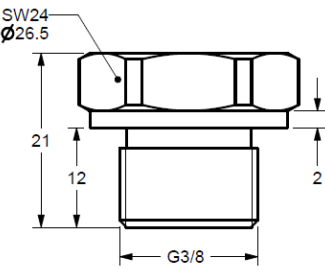
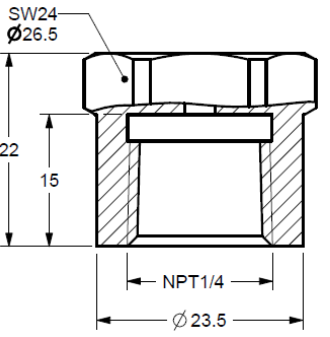
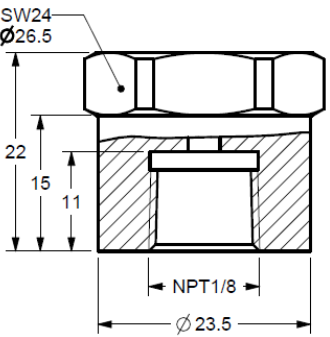
01. 1/2" NPT male <sup>1</sup>	02. 1/4" NPT male <sup>1</sup>	03. G1/2" male <sup>2</sup>
		
04. G1/4" male <sup>2</sup>	05. 1/8" NPT male <sup>1</sup>	06. G1/8" male <sup>2</sup>
		
07. G3/8" male <sup>2</sup>	08. 1/4" NPT female <sup>1</sup>	09. 1/8" NPT female <sup>1</sup>
		

**6. Process Interface (dimensions in mm)**

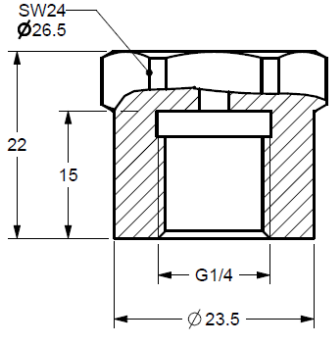
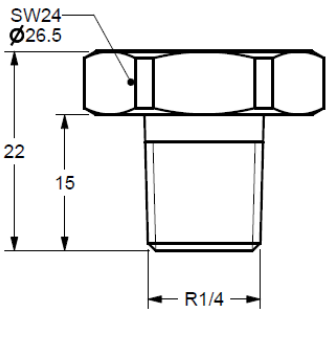
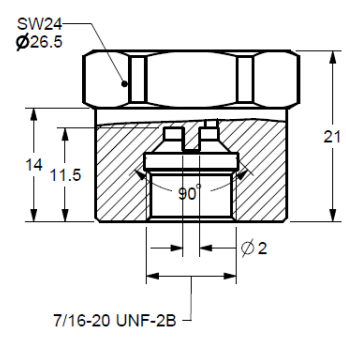
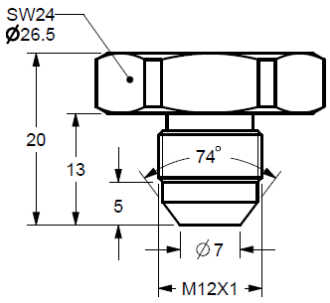
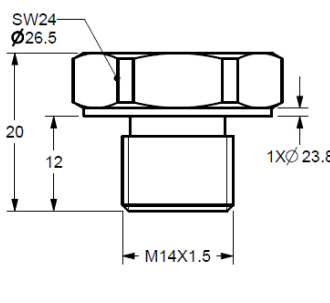
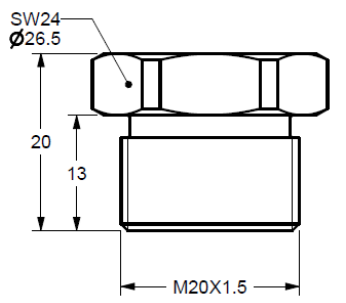
10. G1/4" Female <sup>3</sup>	11. R1/4" male <sup>4</sup>	12. 7/16-20 UNF-2B <sup>5</sup>
		
13. M12x1 male <sup>6</sup>	14. M14x1.5 male <sup>7</sup>	15. M20x1.5 male <sup>7</sup>
		

<sup>1</sup> According to ANSI/ASME B1.20.1

<sup>2</sup> According to ISO 1179-2 (DIN 3852-E)

<sup>3</sup> According to EN837

<sup>4</sup> According to ISO7

<sup>5</sup> According to SAE J513

<sup>6</sup> According to GB/T193

<sup>7</sup> According to ISO 9974-2 (DIN 3852-E)

Note that for pressure ranges greater than 200bar, only options 02, 03, 04, 07 and 15 are available.

### 7. Pressure Conversion Table

Option	Output Type	Equation
01.	4-20mA	$P = \left( \frac{I_{measured} - 4mA}{16mA} \right) * Full\ Scale\ Pressure$
02	0.5 - 4.5V	$P = \left( \frac{V_{measured} - 0.5V}{4V} \right) * Full\ Scale\ Pressure$
03	1- 5V	$P = \left( \frac{V_{measured} - 1V}{4V} \right) * Full\ Scale\ Pressure$
04	0- 5V	$P = \left( \frac{V_{measured}}{5V} \right) * Full\ Scale\ Pressure$

### 8. Ordering Information

#### ESPP-MIT1-NNNNNN-NN-NN-NN

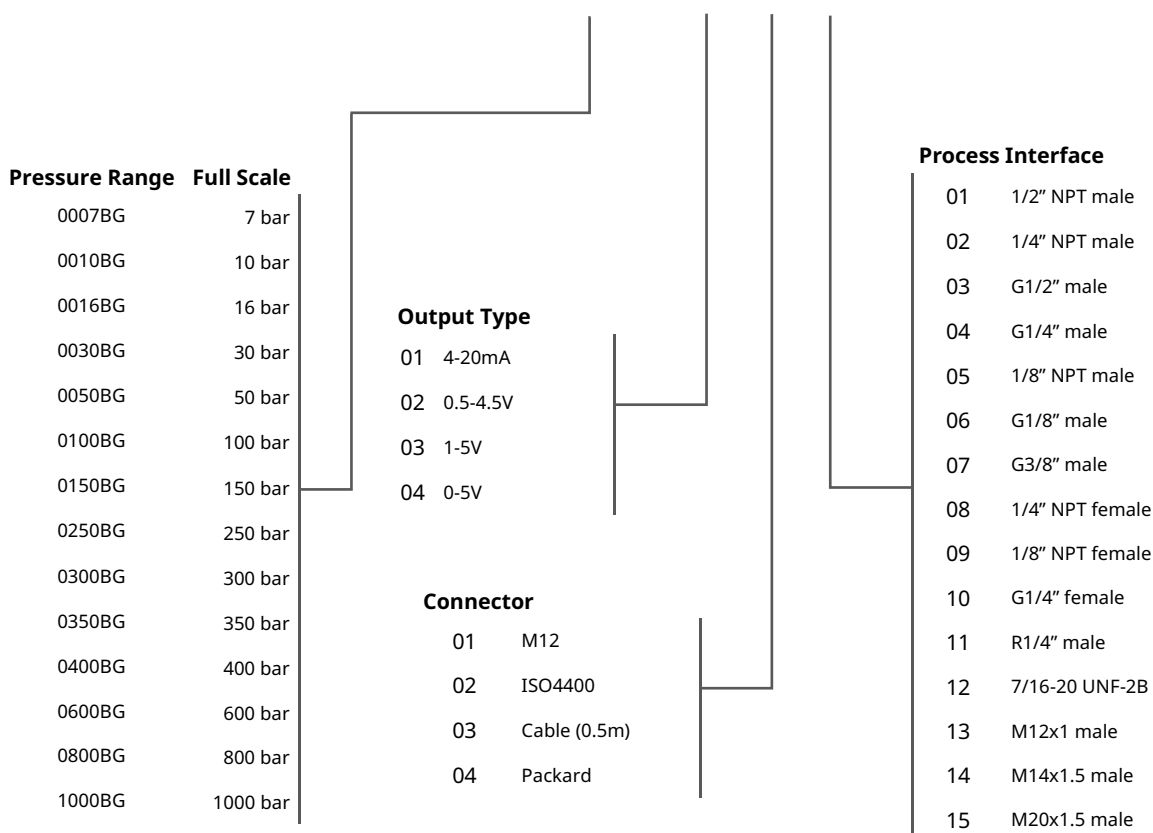

## Important Notes

### PERSONAL INJURY

**DO NOT USE these products as safety or emergency stop devices, or in any other application where failure of the product could result in personal injury.**

Failure to comply with these instructions could result in death or serious injury.

### WARRANTY

ES Systems warrants this Product to be free of defects in materials and workmanship for a period of one (1) year from the date of purchase.

Upon examination by ES Systems, if the unit is found to be defective it will be repaired or replaced at no charge. ES Systems' WARRANTY does not apply to defects resulting from any action of the purchaser, including but not limited to mishandling, improper interfacing, operation outside of design limits, improper repair, or unauthorized modification. This WARRANTY is VOID if the unit shows evidence of having been tampered with or shows evidence of being damaged as a result of excessive corrosion; or current, heat, moisture or vibration; improper specification; misapplication; misuse or other operating conditions outside of ES Systems' control. Components which wear are not warranted.

ES Systems neither assumes responsibility for any omissions or errors nor assumes liability for any damages that result from the use of its Product in accordance with information provided by ES Systems, either verbal or written. ES Systems warrants only that the parts manufactured by it will be as specified and free of defects.

**ES SYSTEMS MAKES NO OTHER WARRANTIES OR REPRESENTATIONS OF ANY KIND WHATSOEVER, EXPRESSED OR IMPLIED, EXCEPT THAT OF TITLE, AND ALL IMPLIED WARRANTIES INCLUDING ANY WARRANTY OF MERCHANTABILITY AND FITNESS FOR A PARTICULAR PURPOSE ARE HEREBY DISCLAIMED.**

No representative of ES Systems is authorized to extend this Warranty or to change it in any manner whatsoever.

No warranty applies to any party other than the original Customer. The remedies of the Customer set forth herein are exclusive and the total liability of ES Systems with respect to this order, whether based on contract, warranty, negligence, indemnification, strict liability or otherwise, shall not exceed the purchase price of the component upon which liability is based.

In no event shall ES Systems be liable for consequential, incidental or special damages.

Specifications may change without notice. The information supplied is believed to be accurate and reliable as of this issue; however, ES Systems assumes no responsibility for its use.

## Contact Information

### ES Systems S.A.

#### Head Office:

7, Stratigi St., GR-154 51  
Neo Psychico, Greece  
Tel: (+30) 210 672 8610,  
Fax (+30) 210 672 8624

#### Factory:

57, I.Metaxa str., GR-194 41  
Koropi, Greece  
Tel: (+30) 216 2000 500,  
Fax (+30) 216 2000 555