

Plug-in Signal Conditioners K-UNIT

SIGNAL TRANSMITTER

(CE, two isolated outputs)

Functions & Features

- Converting a DC input into two standard process signals
- Fast response type available
- High-density mounting

Typical Applications

- Isolation between control room and field instrumentation

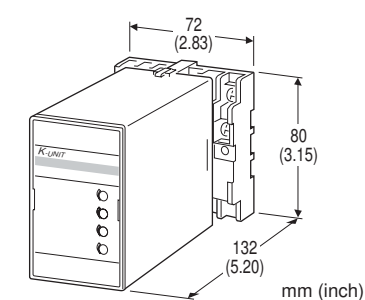

MODEL: KWVS2-[1][2][3]-[4][5]

ORDERING INFORMATION

- Code number: KWVS2-[1][2][3]-[4][5]

Specify a code from below for each of [1] through [5].

- (e.g. KWVS2-6AA-H/K/Q)
- Special input and output ranges (For codes Z & 0)
- Specify the specification for option code /Q (e.g. /C01/S01)

Note: When the user requires a current and a voltage output, specify the current to be the Output 1 which allows a greater load.

[1] INPUT

Current

- A: 4 - 20 mA DC (Input resistance 250 Ω)
- A1: 4 - 20 mA DC (Input resistance 50 Ω)
- B: 2 - 10 mA DC (Input resistance 500 Ω)
- C: 1 - 5 mA DC (Input resistance 1000 Ω)
- D: 0 - 20 mA DC (Input resistance 50 Ω)
- E: 0 - 16 mA DC (Input resistance 62.5 Ω)
- F: 0 - 10 mA DC (Input resistance 100 Ω)
- G: 0 - 1 mA DC (Input resistance 1000 Ω)
- H: 10 - 50 mA DC (Input resistance 100 Ω)
- J: 0 - 10 μA DC (Input resistance 1000 Ω)
- K: 0 - 100 μA DC (Input resistance 1000 Ω)
- GW: -1 - +1 mA DC (Input resistance 1000 Ω)
- FW: -10 - +10 mA DC (Input resistance 100 Ω)

Z: Specify current (See INPUT SPECIFICATIONS)

Voltage

- 1: 0 - 10 mV DC (Input resistance 10 kΩ min.)
- 15: 0 - 50 mV DC (Input resistance 10 kΩ min.)
- 16: 0 - 60 mV DC (Input resistance 10 kΩ min.)
- 2: 0 - 100 mV DC (Input resistance 100 kΩ min.)
- 3: 0 - 1 V DC (Input resistance 1 MΩ min.)
- 4: 0 - 10 V DC (Input resistance 1 MΩ min.)
- 5: 0 - 5 V DC (Input resistance 1 MΩ min.)
- 6: 1 - 5 V DC (Input resistance 1 MΩ min.)
- 4W: -10 - +10 V DC (Input resistance 1 MΩ min.)
- 5W: -5 - +5 V DC (Input resistance 1 MΩ min.)
- 0: Specify voltage (See INPUT SPECIFICATIONS)

[2] OUTPUT 1

Current

- A: 4 - 20 mA DC (Load resistance 600 Ω max.)
- B: 2 - 10 mA DC (Load resistance 1200 Ω max.)
- C: 1 - 5 mA DC (Load resistance 2400 Ω max.)
- D: 0 - 20 mA DC (Load resistance 600 Ω max.)
- E: 0 - 16 mA DC (Load resistance 750 Ω max.)
- F: 0 - 10 mA DC (Load resistance 1200 Ω max.)
- G: 0 - 1 mA DC (Load resistance 12 kΩ max.)
- Z: Specify current (See OUTPUT SPECIFICATIONS)

Voltage

- 1: 0 - 10 mV DC (Load resistance 10 kΩ min.)
- 2: 0 - 100 mV DC (Load resistance 100 kΩ min.)
- 3: 0 - 1 V DC (Load resistance 1000 Ω min.)
- 4: 0 - 10 V DC (Load resistance 10 kΩ min.)
- 5: 0 - 5 V DC (Load resistance 5000 Ω min.)
- 6: 1 - 5 V DC (Load resistance 5000 Ω min.)
- 4W: -10 - +10 V DC (Load resistance 10 kΩ min.)
- 5W: -5 - +5 V DC (Load resistance 5000 Ω min.)
- 0: Specify voltage (See OUTPUT SPECIFICATIONS)

[3] OUTPUT 2

Current

- A: 4 - 20 mA DC (Load resistance 350 Ω max.)
- B: 2 - 10 mA DC (Load resistance 700 Ω max.)
- C: 1 - 5 mA DC (Load resistance 1400 Ω max.)
- D: 0 - 20 mA DC (Load resistance 350 Ω max.)
- E: 0 - 16 mA DC (Load resistance 430 Ω max.)
- F: 0 - 10 mA DC (Load resistance 700 Ω max.)
- G: 0 - 1 mA DC (Load resistance 7000 Ω max.)
- Z: Specify current (See OUTPUT SPECIFICATIONS)

Voltage

Same range availability as Output 1

[4] POWER INPUT

AC Power

- G: 200 V AC

H: 220 V AC

J: 240 V AC

DC Power

S: 12 V DC

R: 24 V DC

[5] OPTIONS (multiple selections)

Response Time (0 - 90 %)

blank: Standard (≤ 0.5 sec.)

/K: Fast Response (Approx. 25 msec.)

Other Options

blank: none

/Q: Option other than the above (specify the specification)

SPECIFICATIONS OF OPTION: Q (multiple selections)

COATING (For the detail, refer to M-System's web site.)

/C01: Silicone coating

/C02: Polyurethane coating

/C03: Rubber coating

TERMINAL SCREW MATERIAL

/S01: Stainless steel

GENERAL SPECIFICATIONS

Construction: Plug-in

Connection: M3.5 screw terminals

Screw terminal: Chromated steel (standard) or stainless steel

Housing material: Flame-resistant resin (black)

Isolation: Input to output 1 to output 2 to power

Overrange output: Approx. -10 to +120 % at 1 - 5 V

Zero adjustment: -5 to +5 % (front)

Span adjustment: 95 to 105 % (front)

Adjustable individually for each output 1 and output 2.

INPUT SPECIFICATIONS

■ **DC Current:**

Shunt resistor attached to the input terminals (0.5 W)

Specify input resistance value for code Z.

■ **DC Voltage:** -30 - +30 V DC

Span: Min. 3 mV, max. 30 V

Offset: Max. 1.5 times span

Input resistance

Span 3 - 10 mV : ≥ 10 k Ω

Span 10 - 100 mV : ≥ 10 k Ω

Span 0.1 - 1 V : ≥ 100 k Ω

Span ≥ 1 V : ≥ 1 M Ω

OUTPUT SPECIFICATIONS

■ **DC Current:** 0 - 20 mA DC

Minimum span: 1 mA

Offset: Max. 1.5 times span

Load resistance: Output drive 12 V max. for Output 1; 7 V max. for Output 2

■ **DC Voltage:** -10 - +12 V DC

Minimum span: 5 mV

Offset: Max. 1.5 times span

Load resistance: Output drive 1 mA max. at ≥ 0.5 V

INSTALLATION

Power input

• **AC:** Operational voltage range: rating ± 10 %, 50/60 ± 2 Hz, approx. 3 VA

• **DC:** Operational voltage range: rating ± 10 % ripple 10 %p-p max., approx. 3 W (125 mA at 24 V)

Operating temperature: -5 to +55°C (23 to 131°F)

Operating humidity: 30 to 90 %RH (non-condensing)

Mounting: Surface or DIN rail

Weight: 400 g (0.88 lb)

PERFORMANCE in percentage of span

Accuracy: ± 0.1 %

Temp. coefficient: ± 0.02 %/°C (± 0.01 %/°F)

Line voltage effect: ± 0.1 % over voltage range

Insulation resistance: ≥ 100 M Ω with 500 V DC

Dielectric strength: 2300 V AC @ 1 minute

(input or output to power to ground)

1350 V AC @ 1 minute (input to output)

1000 V AC @ 1 minute (output 1 to output 2)

STANDARDS & APPROVALS

EU conformity:

EMC Directive

EMI EN 61000-6-4

EMS EN 61000-6-2

Low Voltage Directive

EN 61010-1

Installation Category II

Pollution Degree 2

Input or output to power: Reinforced insulation (300 V)

Input to output: Basic insulation (300 V)

RoHS Directive

EXTERNAL DIMENSIONS unit: mm [inch]

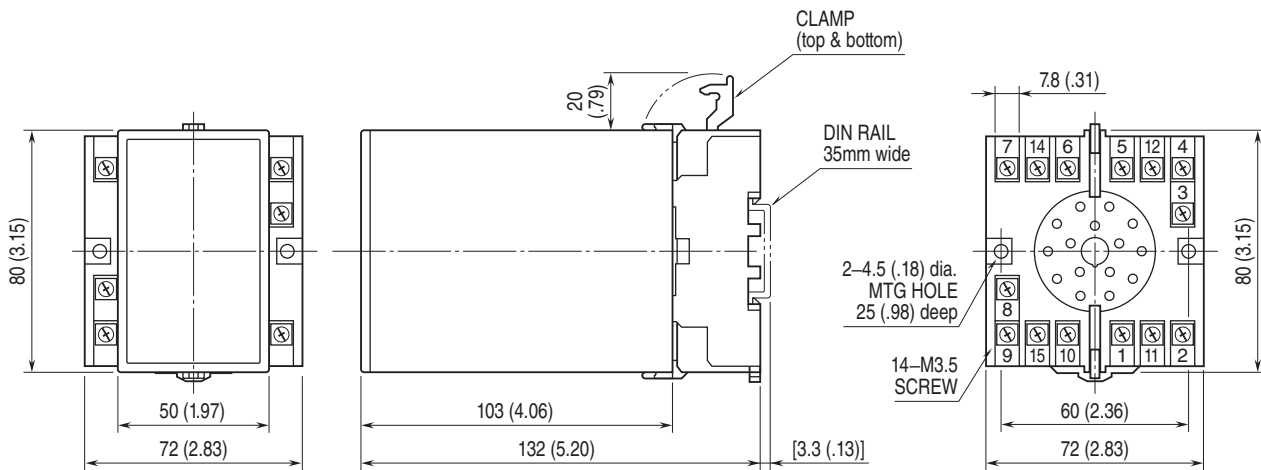

• When mounting, no extra space is needed between units.

TERMINAL ASSIGNMENTS unit: mm [inch]

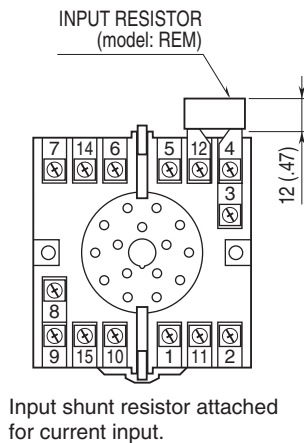

SCHEMATIC CIRCUITRY & CONNECTION DIAGRAM

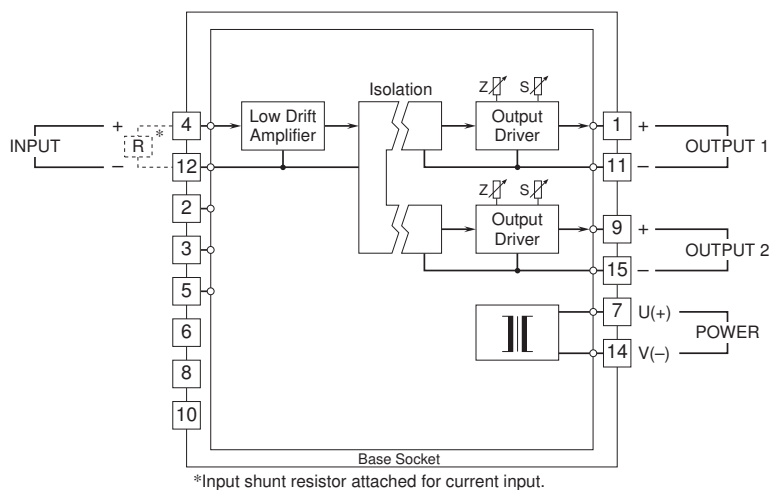



Specifications are subject to change without notice.