

1. Mechanical Dimensions:

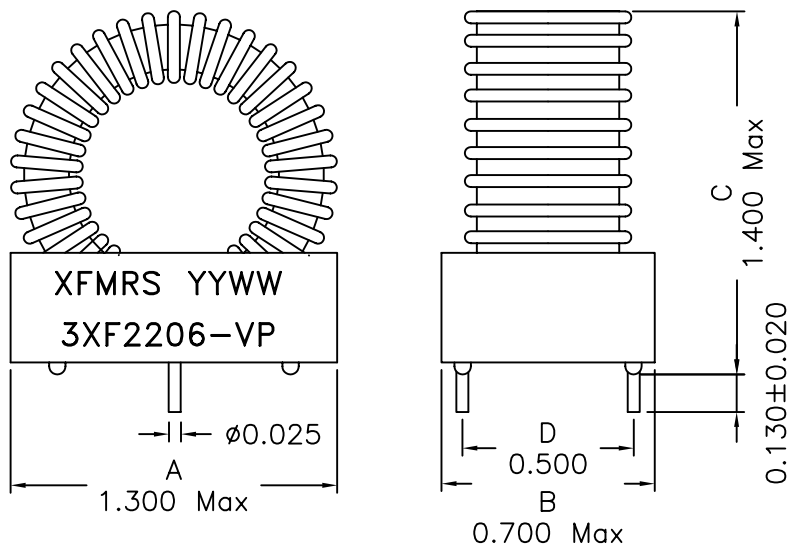

Notes:

1. Solderability: Leads shall meet MIL-STD-202, Method 208D for solderability.
2. Flammability: UL94V-0
3. ASTM oxygen index: > 28%
4. Temperature rating: 155°C. UL file E151556
5. Operating Temperature Range: 0°C to +70°C

2. Schematic:



3. Electrical Specifications: @25°C

OCL: 220uH±10% @10KHz 0.1V

OCL: 154uH Typical @10KHz 0.1V 3.0ADC

DC Resistance: 0.070 Ohms Maximum

DOC. REV A/2

XFMRS Inc	Title: TOROIDAL INDUCTOR		
	UNLESS OTHERWISE SPECIFIED TOLERANCES: .xxx ±0.010 Dimensions in INCH	P/N: 3XF2206-VP	REV A
	DWN.	廖玉坤	Jan-09-02
	CHK.	李清儿	Jan-09-02
SHEET 1 OF 1	APP.	Isaiah M	Jan-09-02