

S2A thru S2M

Surface Mount Glass Passivated Junction Rectifiers Reverse Voltage 50 to 1000V Forward Current 2.0A

FEATURES

- * Plastic package has Underwriters Laboratory Flammability Classification 94V-0
- * High temperature metallurgically bonded construction
- * Cavity-free glass passivated junction
- * Capable of meeting environmental standards of MIL-S-19500
- * 2.0 A operation at TA=75°C with no thermal runaway
- * Typical IR less than 1.0μA
- * High temperature soldering guaranteed: 260°C/10 seconds

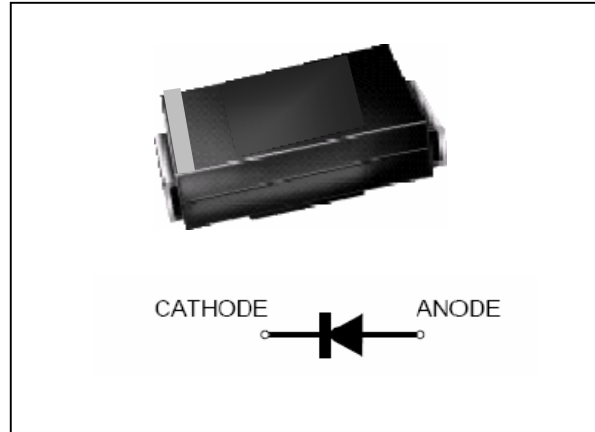

Mechanical Data

Case: JEDEC DO-214AA/SMB, molded plastic over glass Die

Terminals: Plated axial leads, solderable per MIL-STD-750, Method 2026

Polarity: Color band denotes cathode end

Mounting Position: Any

Weight: 0.098 gram

Handling precaution: None

Electrical Characteristic

1. Maximum & Thermal Characteristics Ratings at 25°C ambient temperature unless otherwise specified.

Parameter Symbol	symbol	S2A	S2B	S2D	S2G	S2J	S2K	S2M	Unit
Device marking code		S2A	S2B	S2D	S2G	S2J	S2K	S2M	
Maximum repetitive peak reverse voltage	V_{RRM}	50	100	200	400	600	800	1000	V
Maximum RSM voltage	V_{RSM}	35	70	140	280	420	560	700	V
Maximum DC blocking voltage	V_{DC}	50	100	200	400	600	800	1000	V
Maximum average forward rectified current 0.375" (9.5mm) lead length at $T_A = 75^\circ\text{C}$	$I_{F(AV)}$	2.0							A
Peak forward surge current 8.3ms single half sine-wave superimposed on rated load (JEDEC Method)	I_{FSM}	50							A
Typical thermal resistance (Note 1)	$R_{\theta JA}$	55							°C/W
Operating junction and storage temperature range	T_J, T_{STG}	-50 to +150							°C

Electrical Characteristics Ratings at 25°C ambient temperature unless otherwise specified.

Parameter Symbol	symbol	S2A	S2B	S2D	S2G	S2J	S2K	S2M	Unit
Maximum instantaneous forward voltage at 2.0A	V_F	1.1							V
Maximum DC reverse current $T_A = 25^\circ\text{C}$ at rated DC blocking voltage $T_A = 125^\circ\text{C}$	IR	5.0 100							μA
Typical junction capacitance at 4.0V, 1MHz	CJ	30.0							PF

NOTES:

1. Thermal resistance from junction to ambient at 0.375" (9.5mm) lead length, P.C.B. mounted

We declare that the material of product compliance with ROHS requirements

S2A thru S2M

2. Ratings and Characteristic Curves (TA = 25°C unless otherwise noted)

Fig. 1 - Forward Current Derating Curve

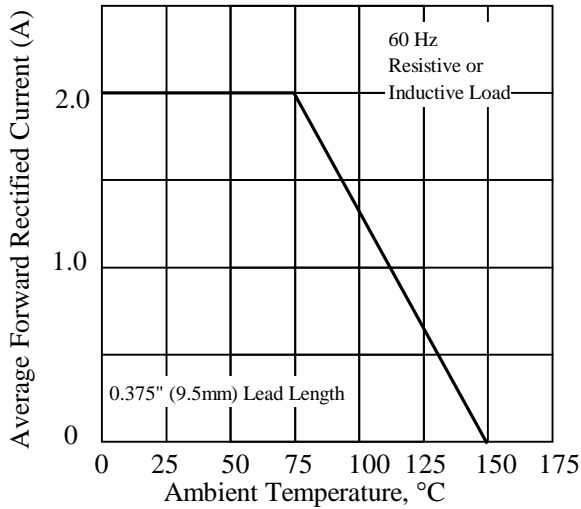

Fig. 2 - Maximum Non-repetitive Peak Forward Surge Current

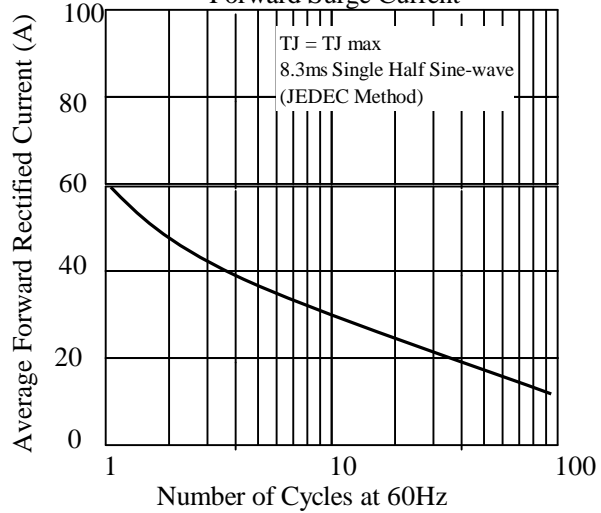

Fig 3. - Typical Instantaneous Forward Characteristics

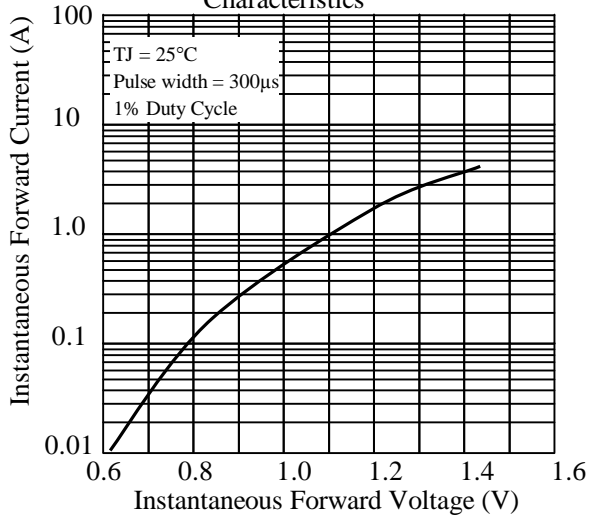

Fig 4. - Typical Reverse Characteristics

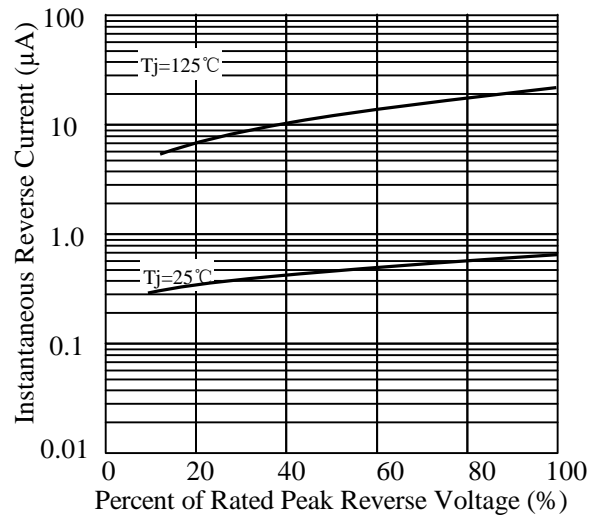

Fig 5. - typical transient thermal impedance

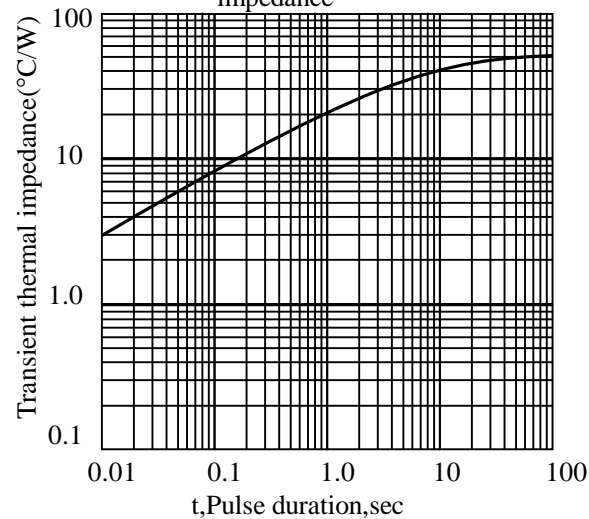
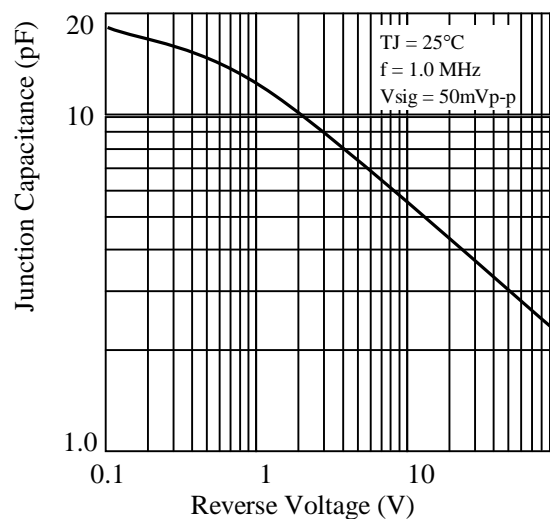
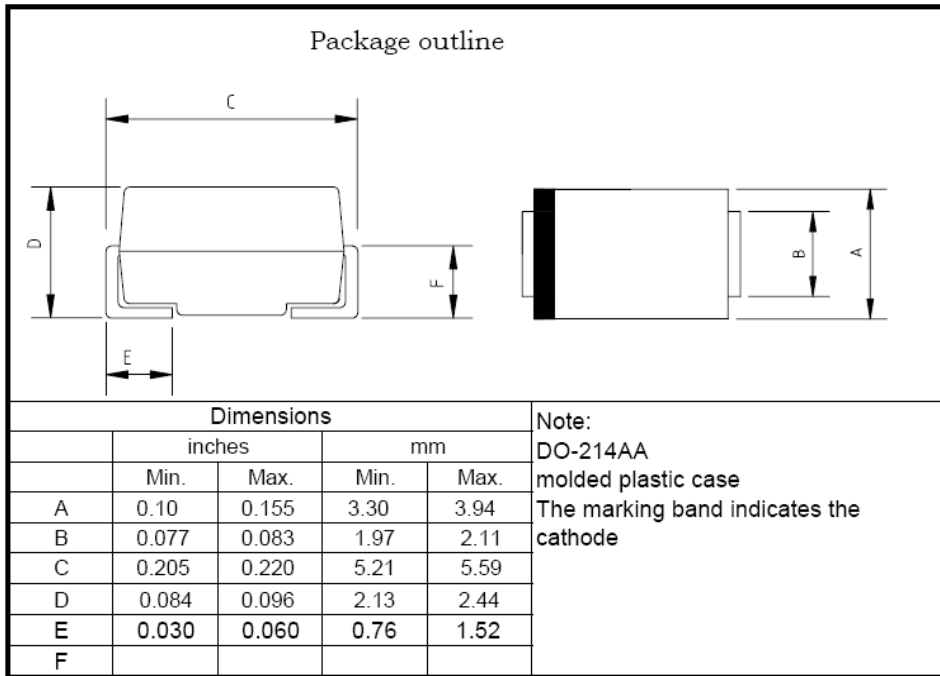

Fig 6. - Typical Junction Capacitance



S2A thru S2M

3. dimension:



Mounting Pad Layout ---SMB

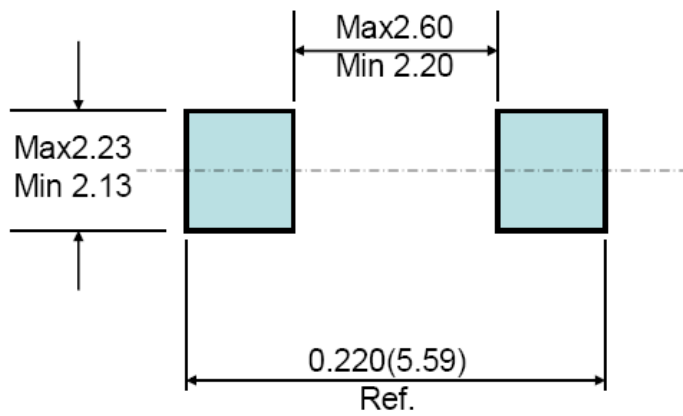

标题Title:

塑封生产线SMD产品包装规范
Packaging specification of SMD

文件编号: WI-258

第 3 版 第 0 次修改

第 2 页

SMD产品通用包装材料规格以及包装产品数量
General packaging materials spec. and quantity

1.1 卷装 reel

A. 卷盘规格 reel spec

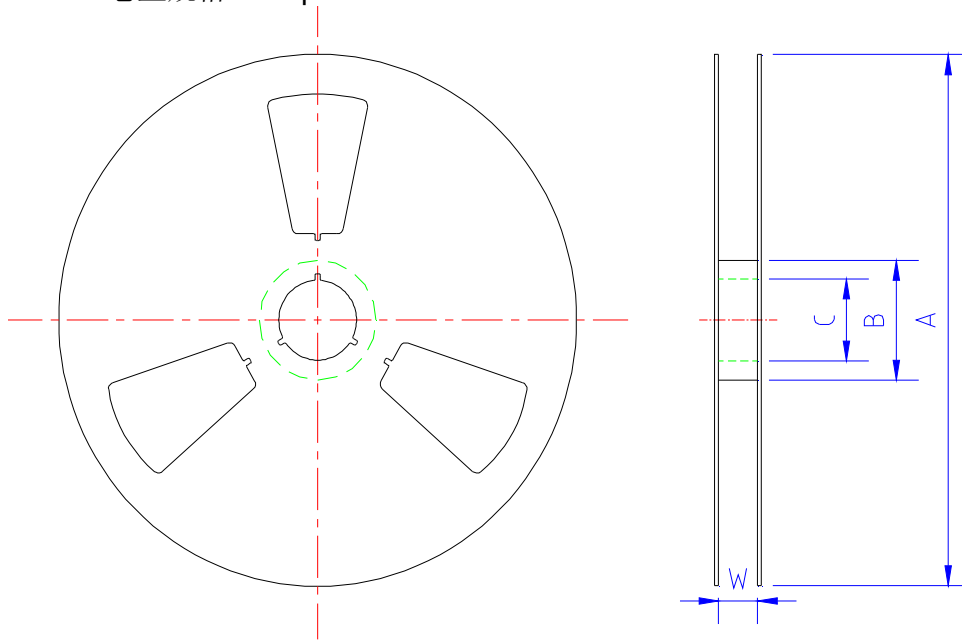

单位: mm

规格	A	B	C	W	每卷数量
SMA 7"卷盘	177.0±2.0	54.0±0.5	13.0±0.5	13.2±0.2	2K
SMA13"卷盘	330.0±2.0	75.0±0.5	13.0±0.5	13.2±0.2	5K
SMB13"卷盘	330.0±2.0	75.0±0.5	13.0±0.5	13.5±0.5	3K
SMC13"卷盘	330.0±2.0	75.0±0.5	13.0±0.5	17.0±0.5	3K

B. 13"卷盘内盒 inner box

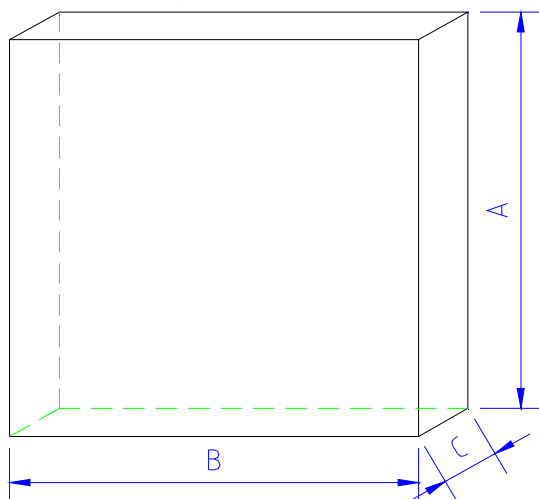

单位: mm

	A	B	C
尺寸	335±5.0	335±2.0	40±1.0

按以上包装方式, 产品包装数量: quantity

规格	每盒数量
SMA13"卷盘	10K
SMB13"卷盘	6K
SMC13"卷盘	6K

标题Title:

塑封生产线SMD产品包装规范
Packaging specification of SMD

文件编号: WI-258

文件编号: WI-258

第 3 页

C. 7"卷盘盒 box

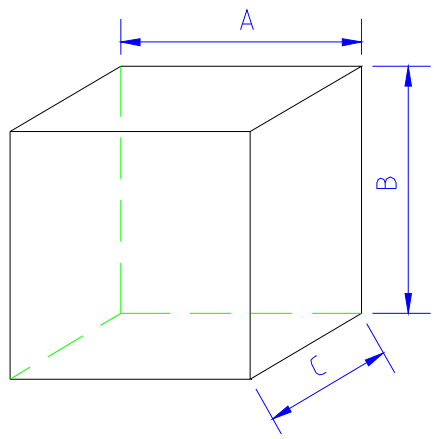

单位: mm

	A	B	C
尺寸	188±2.0	188±2.0	138±2.0

按以上包装方式, 产品包装数量: quantity

	每盒数量
7"卷盘	16K

D. 卷盘外箱 reel carton

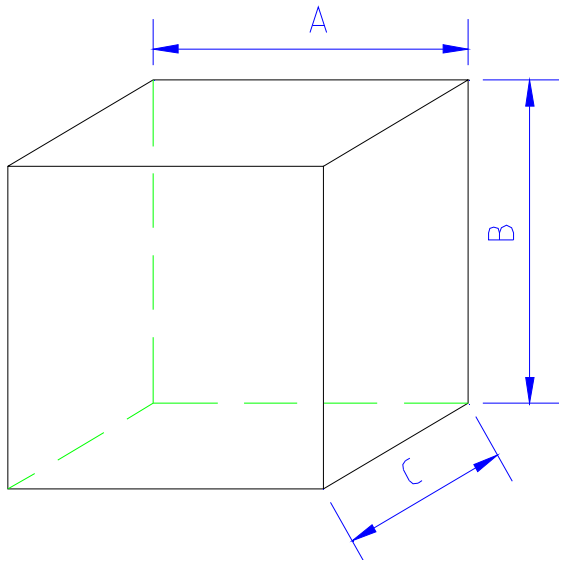

单位: mm

	A	B	C
尺寸	350±2.0	340±2.0	350±2.0

按以上包装方式, 产品包装数量:

规格	每箱数量
SMA 7"卷盘	80K
SMA13"卷盘	80K
SMB13"卷盘	48K
SMC13"卷盘	36K

1.2 编带规格 tape spec

A. 盖带 Cover tape

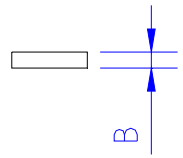

单位: mm

	A	B
SMA	9.30±0.10	0.068±0.005
SMB		
SMC	13.30±0.10	

标题Title:

塑封生产线SMD产品包装规范
Packaging specification of SMD

文件编号: WI-258

第 3 版 第 0 次修改

第 4 页

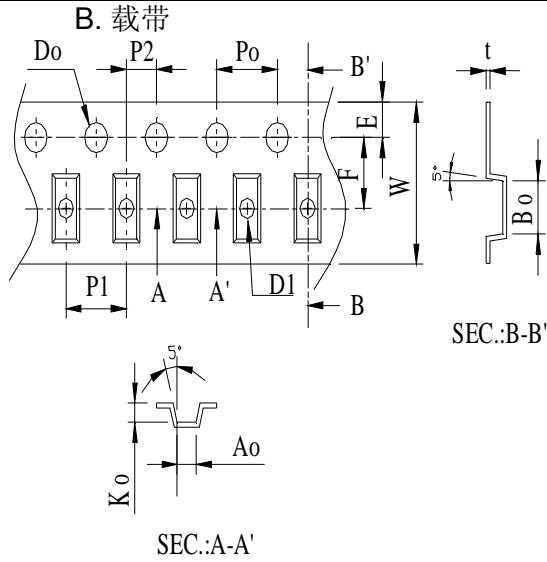

类型	SMA	SMB	SMC
W	12±0.3	12±0.3	16±0.3
P1	4±0.1	8±0.1	8±0.1
E	1.75±0.1	1.75±0.1	1.75±0.1
F	5.5±0.05	5.5±0.05	7.5±0.05
D0	1.55±0.05	1.55±0.05	1.55±0.05
D1	1.5±0.1	1.55±0.05	1.55±0.05
P0	4±0.1	4±0.1	4±0.1
P2	2±0.05	2±0.05	2±0.05
10P0	40±0.2	40±0.2	40±0.2
A0	2.79±0.1	3.8±0.1	6.05±0.1
B0	5.33±0.1	5.4±0.1	8.31±0.1
K0	2.36±0.1	2.45±0.1	2.54±0.1
T	0.25±0.05	0.25±0.05	0.25±0.05

2、SMD产品通用包装规范 General spec of SMD

5.2.1国内客户domestic

A. 7"卷盘reel

所有标签贴在卷盘负极 all the label on cathode side

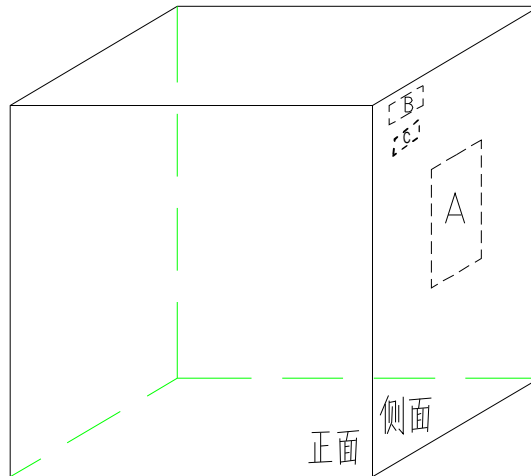
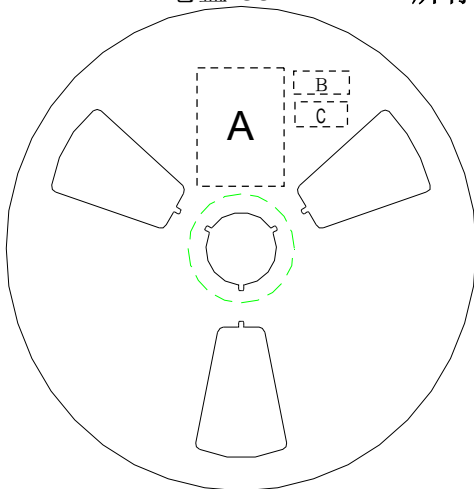

A处:贴LRC标签; B处:贴ROHS标签 C处:贴无卤标签 HF label

B. 13"卷盘

所有标签贴在卷盘负极 all the label (无卤产品才贴HF only)

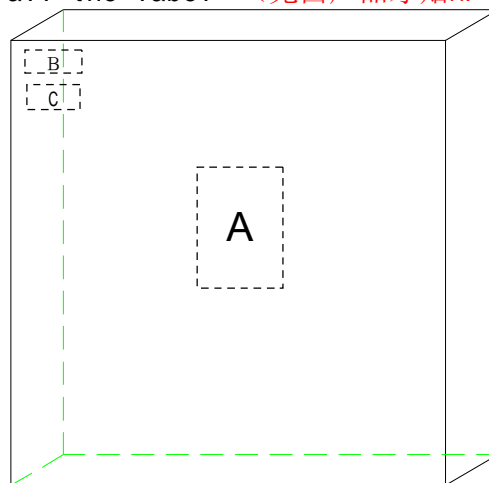
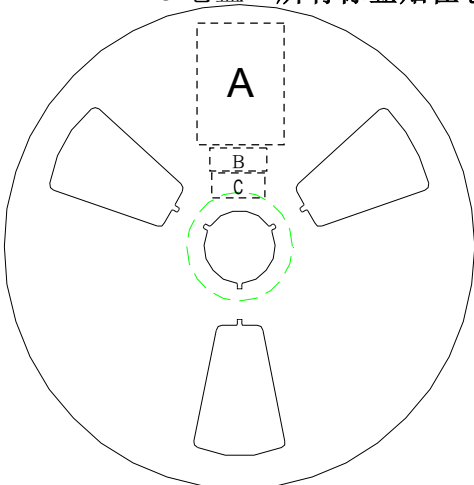

A处:贴LRC标签; B处:贴ROHS标签 C处:贴无卤标签 (无卤产品才贴HF only)

标题Title:

塑封生产线SMD产品包装规范
Packaging specification of SMD

文件编号: WI-258

第 3 版 第 0 次修改

第 5 页

C. 标签要求label spec:

LRC标签label

型号 TYPE	*****	←	LRC产品型号 type
数量(只) QTY(PCS)	*****	←	产品数量 quantity
批号 LOT	*****	←	产品批号 LOT
日期 DATE	*****	←	产品生产日期 date
检验员: CHECKER			

ROHS标签



无卤标签 HF label



2.2 国外客户
overseas

所有标签贴在卷盘负极 all the label on cathode side

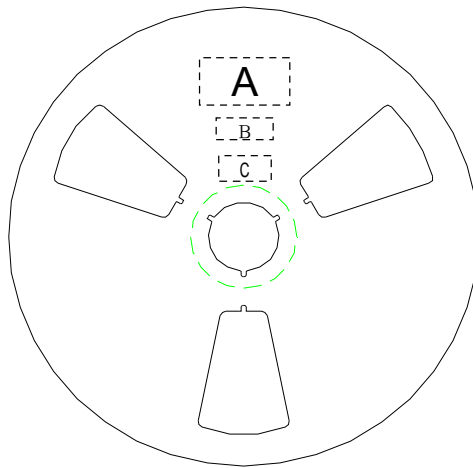

7"卷盘盒 inner box

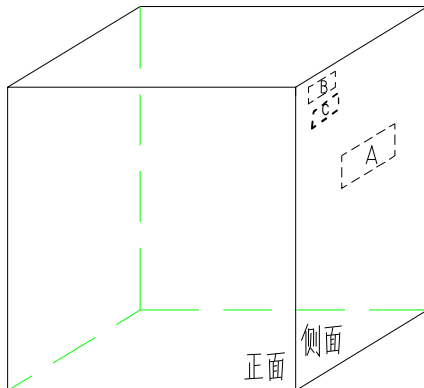

13"卷盘内盒inner box

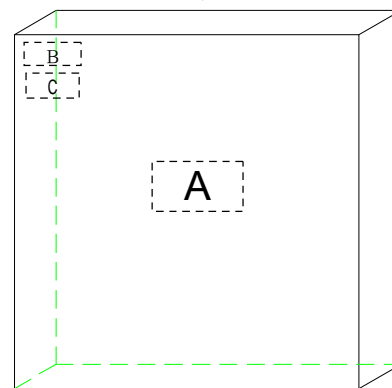

A处:贴LRC标签;

B处:贴ROHS标签

C处:贴无卤标签HF label
(无卤产品才贴HF only)

标题Title:

塑封生产线SMD产品包装规范
Packaging specification of SMD

文件编号: WI-258

第 3 版 第 0 次修改

第 6 页

LRC标签label

TYPE:*****
MARK:*****
Q'TY:*****
DATE:*****

← LRC产品型号

← 印字型号

← 产品数量

← 产品生产日期

ROHS标签



无卤标签 HF label



注意事项NOTE:

1. 13"卷盘内盒装好产品,需用热缩膜包装;13"reel'inner box must be packed by shrink film
2. 所有编带产品卷装完成后,用白色胶带将编带粘牢;

every tape after packing, must be fixed by white adhesive tape

3.1产品出厂检验报告 testing report of the OQC

每批出货时, 需要附上出厂检验报告 every lot must with test report

3.2尾箱

同一编码每批次只允许出现一个尾数箱, 对于尾数物料, 须用缓冲材料对空余部分填充好, 保证物料在受到一定的外作用力下不发生明显移动, 且物料间无碰撞。

The same coding is only one ending for each batch box materials for the mantissa to be good filled with cushioning material.

S2A thru S2M

4. Update Record

版次	更新记录	更新作者	更新日期
1	第一版	周杰	2011-7-1