

Customer Information Sheet

DRAWING No.: M20-999XXXX

SHEET 2 OF 2

IF IN DOUBT - ASK

©

NOT TO SCALE

THIRD ANGLE PROJECTION

ALL DIMENSIONS IN mm

NOTES:

1. RECOMMENDED PCB MOUNTING HOLE SIZE = $\varnothing 1.00\text{mm}$.
2. ALL TOLERANCES ARE $\pm 0.25\text{mm}$ UNLESS OTHERWISE STATED.
3. FOR COMPLETE SPECIFICATION, SEE COMPONENT SPECIFICATION C001XX (LATEST ISSUE).

SPECIFICATION:

MATERIAL:

MOULDING:

- 05 & 06 = GLASS-FILLED POLYESTER UL94V-0, BLACK
- 45 & 46 = HIGH TEMP NLYON 6T UL94V-0, BLACK

PINS = BRASS

FINISH:

PINS:

- 05 = GOLD
- 06 = TIN/LEAD
- 45 = GOLD
- 46 = 100% TIN

ELECTRICAL:

- CURRENT RATING = 3A MAX
- CONTACT RESISTANCE = 25 mΩ MAX (GOLD), 30 mΩ MAX (TIN)
- INSULATION RESISTANCE = 1,000 MΩ MIN
- DIELECTRIC STRENGTH = 750V AC/DC

MECHANICAL:

- DURABILITY = 300 OPERATIONS (GOLD), 50 OPERATIONS (TIN)

ENVIRONMENTAL:

- TEMPERATURE RANGE = -40°C TO +105°C

PACKING:

BAG

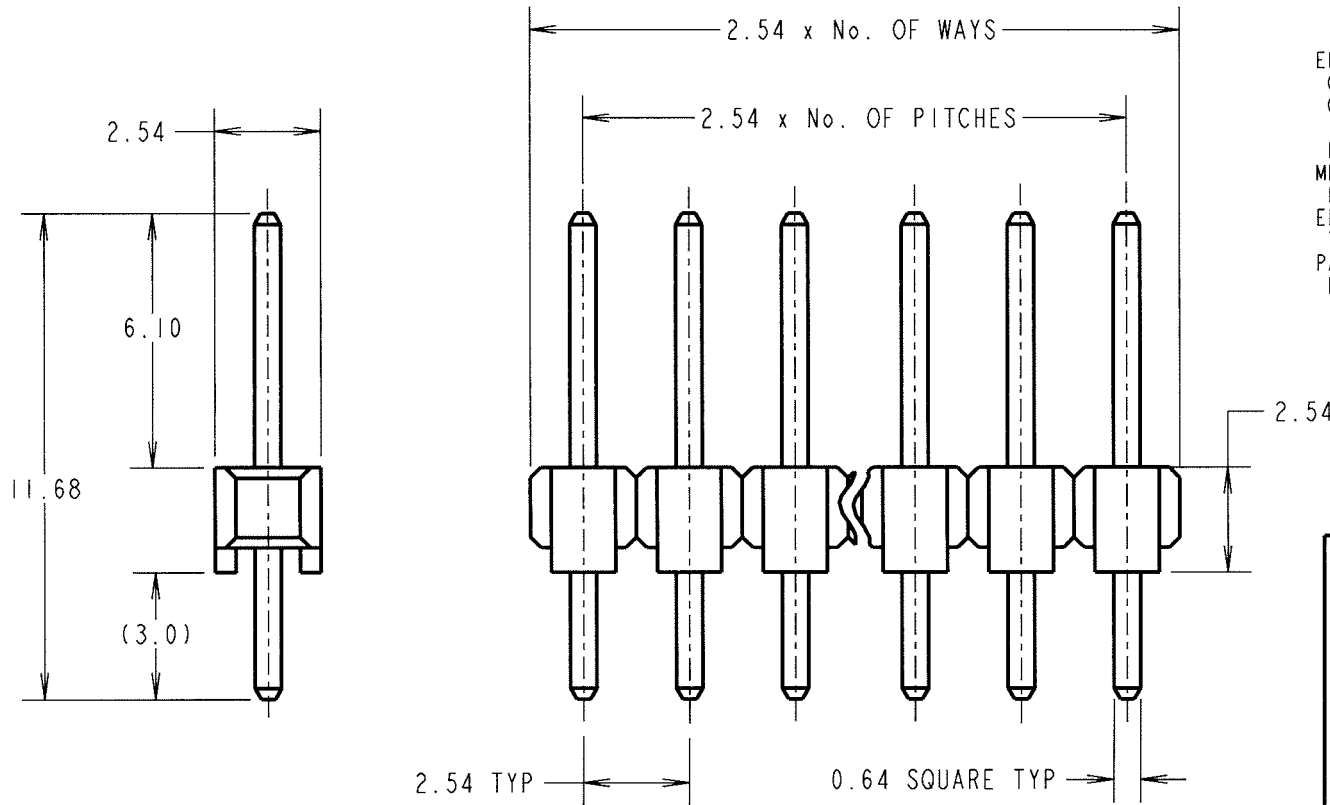

ORDER CODE: **M20-999XXXX**

No. OF WAYS: _____
02 TO 40

FINISH: _____
05 = GOLD
06 = TIN/LEAD
45 = GOLD
46 = 100% TIN

JAE	18	18.03.05	8458
NAME	ISS.	DATE	C/NOTE
APPROVED: <i>[Signature]</i>			
CHECKED: <i>[Signature]</i>			
DRAWN: P.ALEXANDER			
CUSTOMER REF.:			
ASSEMBLY DRG:			



HARWIN INC U.S.A. TEL: (812) 542 2540 FAX: (812) 542 2541	HARWIN PLC U.K. TEL: 023 9231 4545 FAX: 023 9231 4590	HARWIN PTE SINGAPORE TEL: 65 6779 4909 FAX: 65 6779 3868
--	--	---

THIS DRAWING AND ANY INFORMATION OR DESCRIPTIVE MATTER SET OUT HEREON ARE CONFIDENTIAL AND COPYRIGHT PROPERTY OF THE HARWIN GROUP AND MUST NOT BE DISCLOSED, LOANED, COPIED OR USED FOR MANUFACTURING, TENDERING OR FOR ANY OTHER PURPOSE WITHOUT THEIR WRITTEN PERMISSION.

TOLERANCES

~~X = ±1mm~~
~~X.X = ±0.25mm~~
~~X.XX = ±0.10mm~~
~~X.XXX = ±0.01mm~~

ANGLES = ±5°
UNLESS STATED

MATERIAL: SEE ABOVE

FINISH: SEE ABOVE

S/AREA: mm²

TITLE: 2.54mm PITCH SIL VERTICAL PC TAIL PIN HEADER ASSEMBLY

DRAWING NUMBER: M20-999XXXX