



DESCRIPTION

The AA4556 integrated circuit is a high-gain, high output current dual operational amplifier capable of driving $\pm 70\text{mA}$ into 150Ω loads (10.5V output voltage), and operating low supply voltage ($V_+/V_- = \pm 2\text{V}$). The AA4556 has the capability of driving 150Ω loads. In addition, the wide band-width, low noise, high slew rate and low distortion of the AA4556 make it ideal for many audio, telecommunications and instrumentation applications.

FEATURES

- Operating Voltage ($\pm 2\text{V} \sim \pm 18\text{V}$)
- High Output Current ($I_o = 70\text{mA}$)
- Slew Rate ($3.5\text{V}/\mu\text{s}$)
- Gain Band Width Product (8MHz)
- Bipolar Technology

APPLICATION

- Audio Technology
- Telecommunication Circuit
- Instrumentation Application

BLOCK DIAGRAM

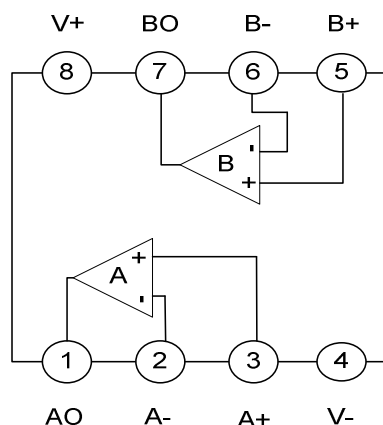

■ PIN DESCRIPTION

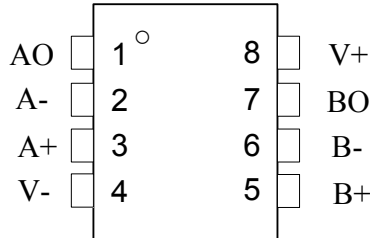

TOP VIEW

PIN NO.	PIN NAME	FUNCTION
1	AO	Amplifier A Output
2	A-	Amplifier B Invert Input
3	A+	Amplifier A Non-Invert Input
4	V-	Negative Voltage Supply
5	B+	Amplifier B Non-Invert Input
6	B-	Amplifier B Invert Input
7	BO	Amplifier B Output
8	V+	Postive Voltage Supply

■ ABSOLUTE MAXIMUM RATINGS

Ta=25°C

SYMBOL	PARAMETER	RATINGS	UNIT
V _{CC}	Supply voltage	±18V	V
V _{IDR}	Input Differential Voltage Range	±30	V
V _{ICR}	Input Common Mode Voltage Range	±15	V
T _A	Operating Ambient Temperature	-20 ~+75	°C
T _S	Storage Temperature	-40~+125	°C



■ ELECTRICAL CHARACTERISTICS

($V_+/V_- = \pm 15\text{ V}$, $T_A = 25^\circ\text{C}$, unless otherwise noted.)

SYMBOL	PARAMETER	TEST CONDITIONS	LIMITS			UNIT
			MIN	TYP	MAX	
V_{IO}	Input Offset Voltage	$R_S \leq 10\text{ k}\Omega$	-	0.5	6	mV
I_{IO}	Input Offset Current		-	5	60	nA
I_{IB}	Input Bias Current		-	50	500	nA
V_{ICR1}	Input Common Mode Voltage Range1	$V_+ = 9\text{ V}$, V_{IL}	-	-	1.5	V
V_{ICR2}	Input Common Mode Voltage Range2	$V_+ = 9\text{ V}$, V_{IH}	8	-	-	V
A_{VOL}	Large Signal Open Loop Voltage Gain	$R_L \geq 2.0\text{ k}\Omega$, $V_O = \pm 10\text{ V}$	86	100	-	dB
CMR	Common Mode Rejection	$R_S \leq 10\text{ k}\Omega$	70	90	-	dB
PSR	Power Supply Rejection	$R_S \leq 10\text{ k}\Omega$	76.5	90	-	dB
V_{OH}	Output Voltage–High Limit	$V_+ = 9\text{ V}$, $V_{in+} = 4\text{ V}$, $V_{in-} = 3\text{ V}$, $I_{source} = 40\text{ mA}$	7.5	-	-	V
V_{OL}	Output Voltage–Low Limit	$V_+ = 9\text{ V}$, $V_{in+} = 3\text{ V}$, $V_{in-} = 4\text{ V}$, $I_{sink} = 40\text{ mA}$	-	-	21	V
I_{CC}	Power Supply Current	$V_+ = 9\text{ V}$	-	8	12	mA
SR	Slew Rate		-	3.5	-	$\text{V}/\mu\text{s}$



ORDERING INFORMATION

ORDER NO.	PACKAGE	PACKING	Q'TY	MARK CHART	
AA4556S	SOP 8L	TAPE & REEL	3,000ea	<table border="1" style="margin-left: auto; margin-right: auto;"> <tr> <td>AA4556 XXXX S</td> </tr> </table>	AA4556 XXXX S
AA4556 XXXX S					

PACKAGE DIMENSION

SOP-8

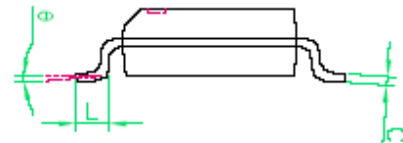
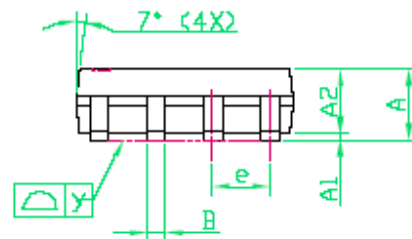
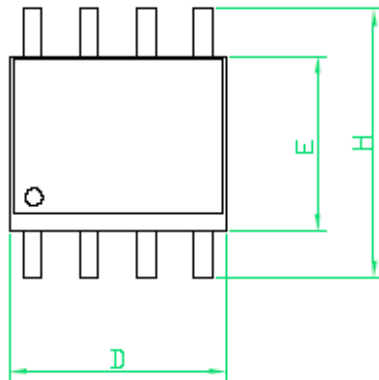

SYMBOLS	DIMENSIONS IN MILLIMETERS			DIMENSIONS IN INCHES		
	MIN	NOM	MAX	MIN	NOM	MAX
A	1.35	1.60	1.75	0.053	0.063	0.069
A1	0.10	---	0.25	0.004	---	0.010
A2	---	1.45	---	---	0.057	---
b	0.33	---	0.51	0.013	---	0.020
C	0.19	---	0.25	0.007	---	0.010
D	4.80	---	5.00	0.189	---	0.197
E	3.80	---	4.00	0.150	---	0.157
e	---	1.27	---	---	0.050	---
H	5.80	---	6.20	0.228	---	0.244
L	0.40	---	1.27	0.016	---	0.050
y	---	---	0.10	---	---	0.004
θ	0°	---	8°	0°	---	8°

NOTES:

- Package body sizes exclude mold flash protrusions or gate burns.
- Tolerance ± 0.1 mm (4 mil) unless otherwise specified
- Coplanarity: 0.1 mm
- Controlling dimension is millimeter converted inch dimensions are not necessarily exact
- Followed from JEDEC MS-012