

0.5W Power Light LED



Lead-Free Parts

LG-5630WKZ-DT-1-T150-CW-D01

DATA SHEET

DOC. NO : QW0905-LG-5630WKZ-DT-1-T150-CW-D01

REV. : B

DATE : 28 - Jun. - 2012



Product Model Designation System

LG - 56 30 WK Z - D T - 1 - T150 - P - CW - D01

A B C D E F G H I J K L

A	B	C	D	E
Title	Dimension(L)	Dimension(W)	Emitting Color	Zener
LG:Ligitek	57:5.7mm 56:5.6mm	30:3.0mm	WK:White Color	
F	G	H	I	J
Epoxy Color	Package	Chip Modification	Test Current	Patent
D:Yellow Diffused	T:Tape&Reel	-X: 2 chip in 1(Parallel) -1: 1 chip in 1 -2: 2 chip in 1(Series)	T60: 60mA T150: 150mA	P: IP Free

K **L**
Chromaticity Coordinates Bin Modification
-CW: Cool White
-NW: Neutral White
-WW: Warm White

Features

- *. White colored SMTpackage
- *. Suitable for all SMT assembly and soldering methods
- *. Pb-Free Reflow soldering application
- *. More Energy Efficient than Incandescent and most Halogen lamps.
- *. RoHS compliant

Typical Applications

- *. Reading Light (car,bus,aircraft)
- *. Portable(flashlight,bicycle).
- *. Backlights(Monitor,TV) / Light Guides.
- *. Automotive Exterior (Stop-Tail-Turn,CHMSL,Mirror Side Repeat).
- *. Commercial and Residential Architectural lighting.
- *. Mini-accent / Uplighters / Downlighters / Orientation lighting
- *. Fiber Optic Alternative / Decorative / Entertainment lighting.
- *. Security / Garden lighting.
- *. Cove / Undershef / Task lighting.
- *. Traffic signaling / Beacons / Rail crossing and Wayside lighting.

Dimension

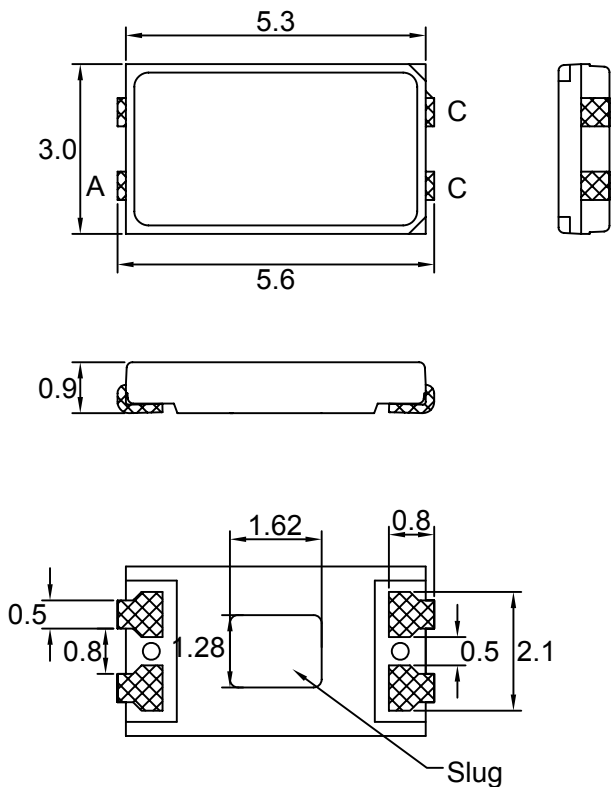

Recommended Solder Patterns

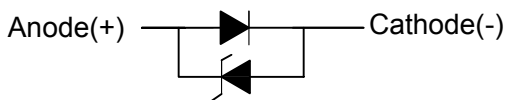
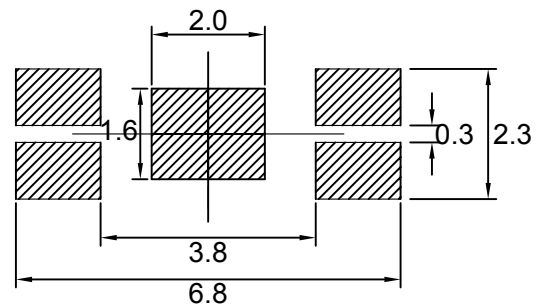

Note:

1. The tolerance unless mentioned is $\pm 0.1\text{mm}$, unit=mm.
2. The slug has polarity as anode.
3. It is strongly recommended to apply on electrically isolated heat conducting film between the slug and contact surfaces.

Absolute Maximum Ratings at Ta=25°C

Parameter	Symbol	Ratings	UNIT
		Cool White	
DC Forward Current	IF	150	mA
Power Dissipation	PD	0.6	W
Peak pulse current Duty 1/10@10KHz	IFP	200	mA
LED junction Temperature	Tj	125	°C
Reverse Current(VR=5V)	Ir	10	μA
ESD Sensitivity	VB	±2000	V
Storage Temperature	Tstg	-40 ~ +100	°C
Operating Temperature	Topr	-40 ~ +85	°C
Soldering Temperature	Tp	260	°C

Note:

- 1.Proper current derating must be observed to maintain temperature below the maximum.
- 2.LEDS are not designed to be driven in reverse bias.

Luminous Intensity Characteristics at 150mA (Ratings At 25°C Ambient)

PART NO	Emission Color	Luminous Intensity			Units
		Min.	Typ.	Max.	
LG-5630WKZ-DT-1-T150-CW-D01	Cool White	48	51	----	lm

Note :

1. Cool White emitters are built with InGaN.
2. Luminous Intensity is measured with an accuracy of ±10%

Forward Voltage Characteristics at 150mA

(Ratings At 25°C Ambient)

PART NO	Emission Color	Vf			Units
		Min.	Typ.	Max.	
LG-5630WKZ-DT-1-T150-CW-D01	Cool White	----	3.3	3.8	V

Note : Forward Voltage is measured with an accuracy of $\pm 0.1V$

Chromaticity Coordinates Characteristics at 150mA

(Ratings At 25°C Ambient)

PART NO	Emission Color	Chromaticity Coordinates			
		X		Y	
		Min.	Max.	Min.	Max.
LG-5630WKZ-DT-1-T150-CW-D01	Cool White	0.315	0.347	0.32	0.372

Note : ± 0.01 is tester tolerance.

Emission Angle Characteristics at 150mA

(Ratings At 25°C Ambient)

PART NO	Emission Color	Lambertian	Units
LG-5630WKZ-DT-1-T150-CW-D01	Cool White	120	Degrees

Color Rendering Index Characteristics at 120mA

(Ratings At 25°C Ambient)

PART NO	Emission Color	CRI		
		Min.	Typ.	Max.
LG-5630WKZ-DT-1-T150-CW-D01	Cool White	70	----	----

Bin Code Description

Bin Code		
Luminous Intensity	CIE	Forward Voltage
F45T	WO	3.0-3.2

Luminous Intensity (lm) @IF=150mA		
Bin Code	Min.	Max.
F48T	48	51
F51T	51	54
F54T	54	57
F57T	57	60

Color Rank @IF=150mA
VN
VO
WN
WO

Forward Voltage(V) @IF=150mA
2.8-3.0
3.0-3.2
3.2-3.4
3.4-3.6
3.6-3.8

Bins Code of chromaticity coordinates

Color Coordiante at 150mA									
CCT(K)	BIN CODE	1		2		3		4	
		X	Y	X	Y	X	Y	X	Y
5000~5650	VN	0.329	0.357	0.347	0.372	0.346	0.359	0.329	0.345
	VO	0.329	0.345	0.346	0.359	0.344	0.344	0.329	0.331
5650~6300	WN	0.315	0.344	0.329	0.357	0.329	0.345	0.316	0.333
	WO	0.316	0.333	0.329	0.345	0.329	0.331	0.317	0.32

NOTE: Tolerance on each color bin(x,y)is±0.01

The C.I.E 1931 Chromaticity Coordinates

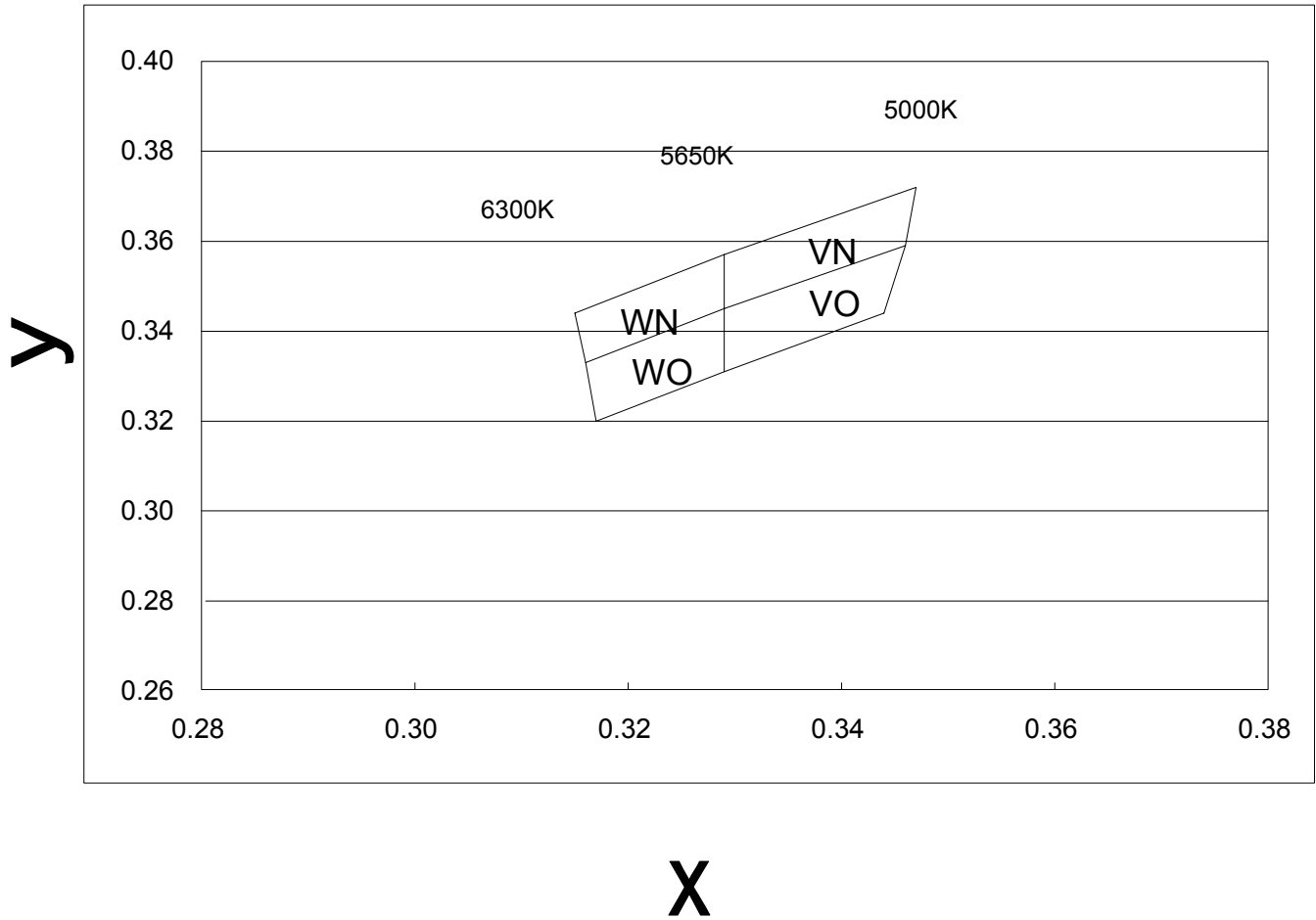

Recommended Profile for Reflow Soldering

Pb -free solder temperature profile

Pb -free solder Temperature profile	
Pre-heat	180-200°C
Pre-heat time	120 Sec Max
Peak-Temperature	260°C Max
Soldering time condition	10 Sec Max

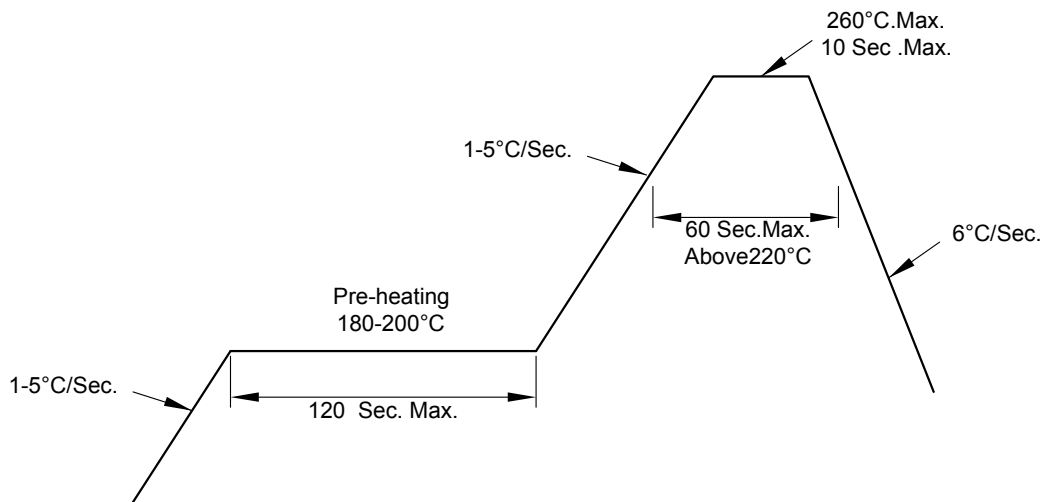

- (1) Reflow soldering should not be done more than two times.
- (2) When soldering, do not put stress on the LEDs during heating.
- (3) After soldering, do not warp the circuit board.
- (4) The encapsulated material of the LEDs is silicone.
Precautions should be taken to avoid the strong pressure on the encapsulated part. So when using the chip mounter, the picking up nozzle that does not affect the silicone resin should be used.

Hand Soldering Conditions:

Do not exceed 3 seconds at maximum 320°C under soldering iron. (one time only)

Fig.1 Forward current vs. Forward Voltage**Fig.2 Forward current vs. Luminous Intensity**

Fig.5 Luminous Spectrum($T_a=25^{\circ}\text{C}$)

Fig.6 Directivity Radiation



Carrier Type Dimensions

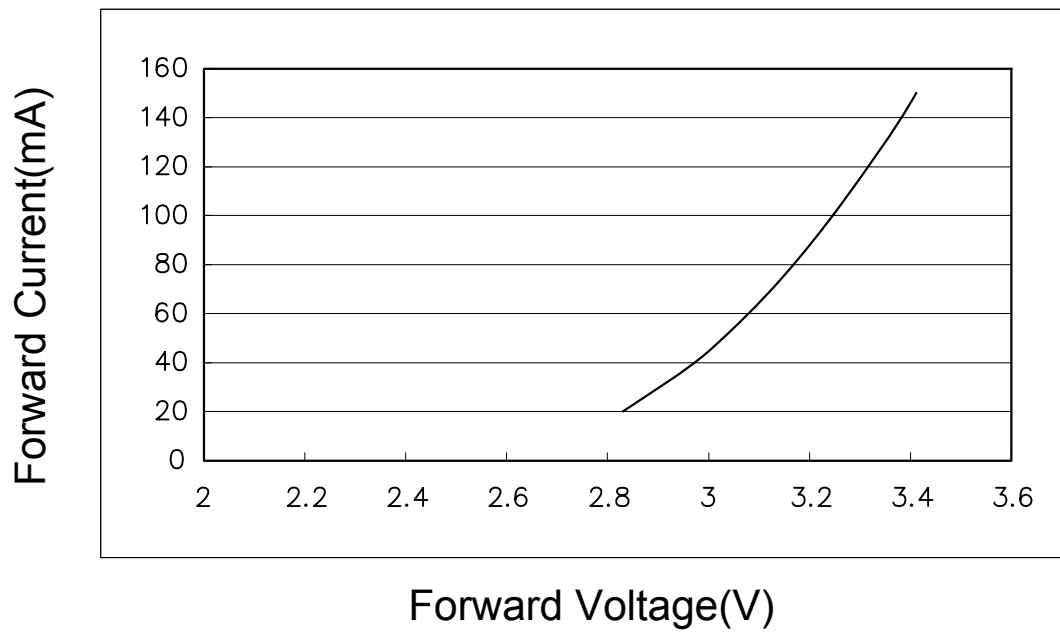
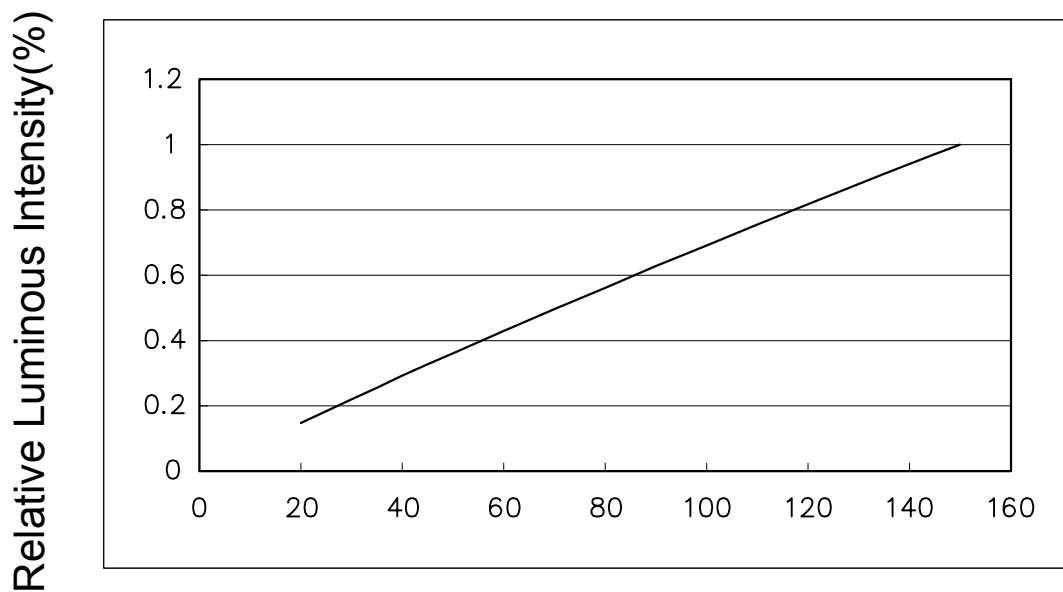

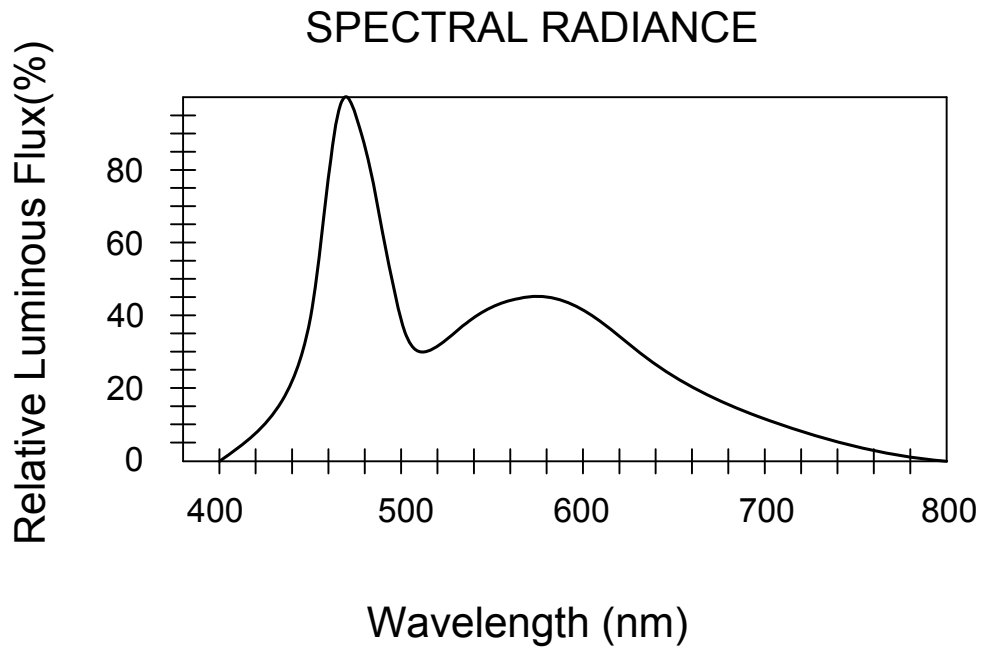
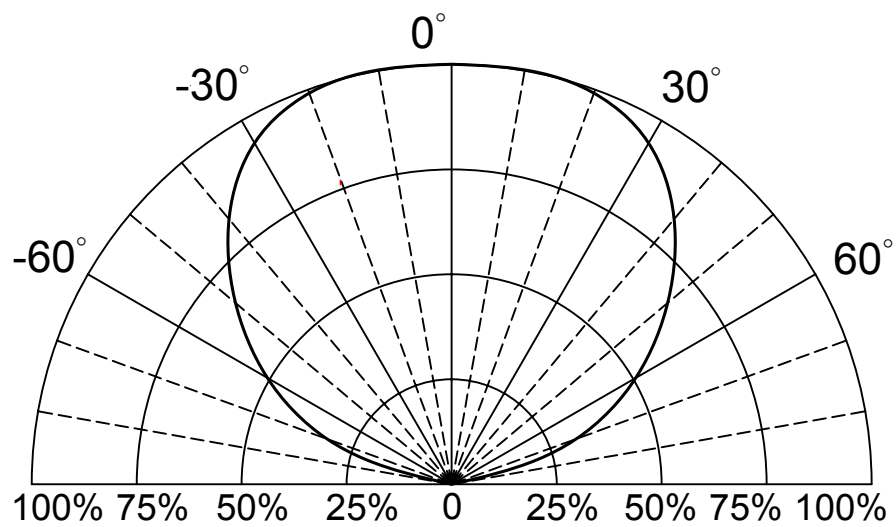
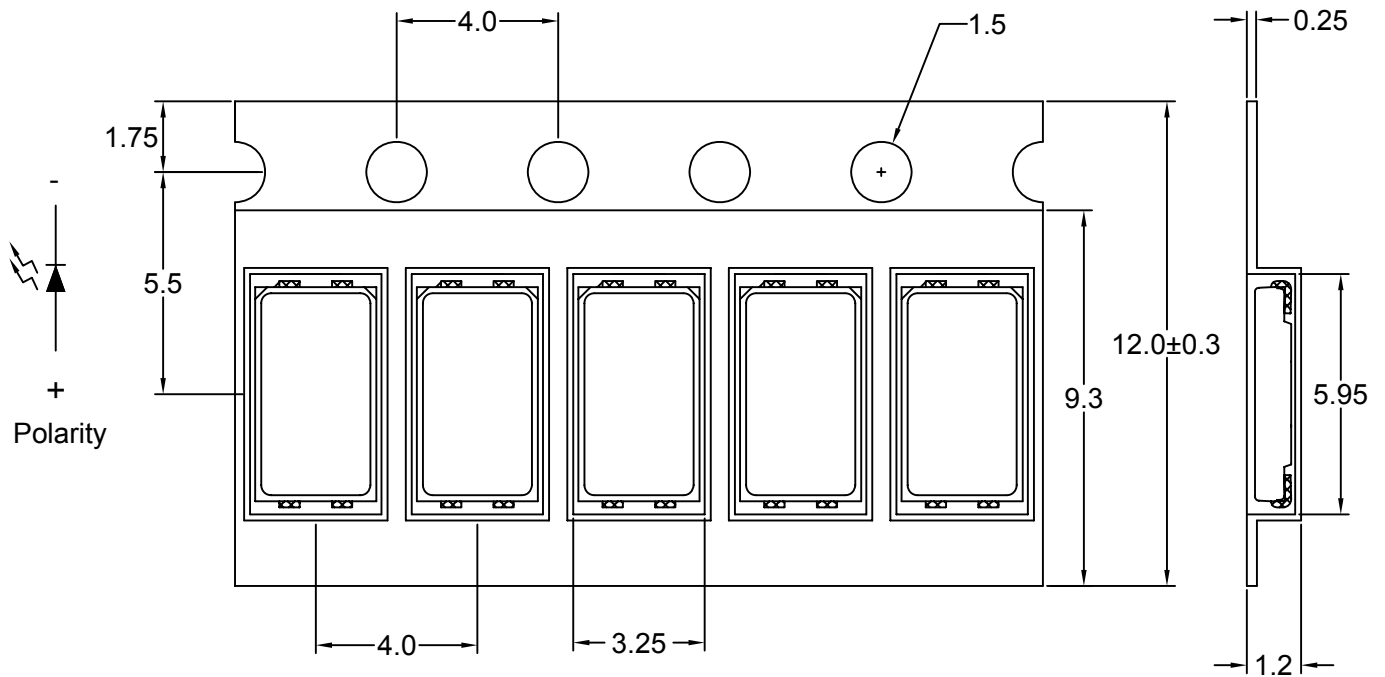



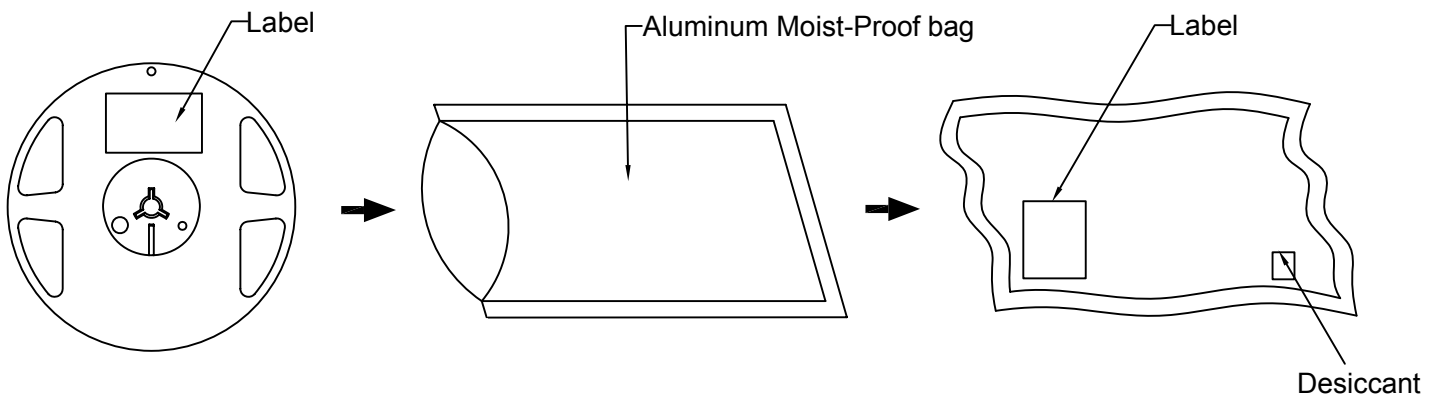

Note : The tolerances unless mentioned is $\pm 0.2\text{mm}$.

Packing Specifications



Label Explanation

	LIGITEK ELECTRONICS CO., LTD.	
		
	PART :	LG-5630WKZ-DT-1-T150-CW-D01
		
	LOT :	GS1-060109
		
QTY(PCS):	2000	
		
BIN/HUE :	F48T/WO	VF:3.0-3.2

BIN : Luminous Flux

HUE : Chromaticity Coordinates
(CIE_x , CIE_y)

3.0 - 3.2 : Forward Voltage

Reel Dimensions

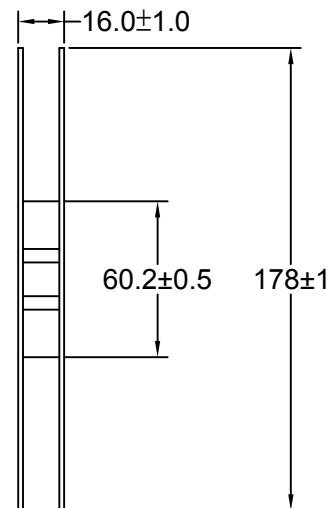
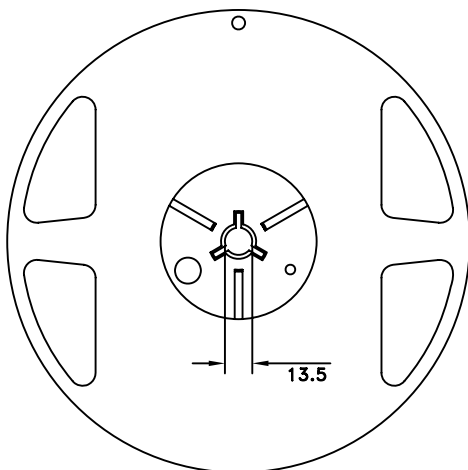

Box Explanation

1. 4 BAG / INNER BOX
2. INNER BOX SIZE : L X W X H 23cm X 8.5cm x 26cm

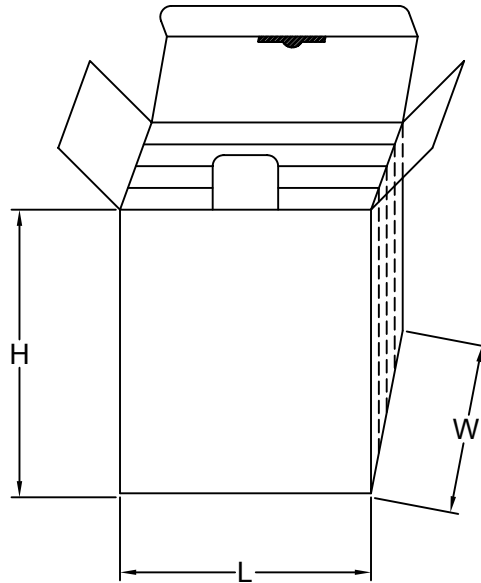

3. 10 INNER BOXES / CARTON
4. CARTON SIZE : L X W X H 58cm X 34cm x 35cm

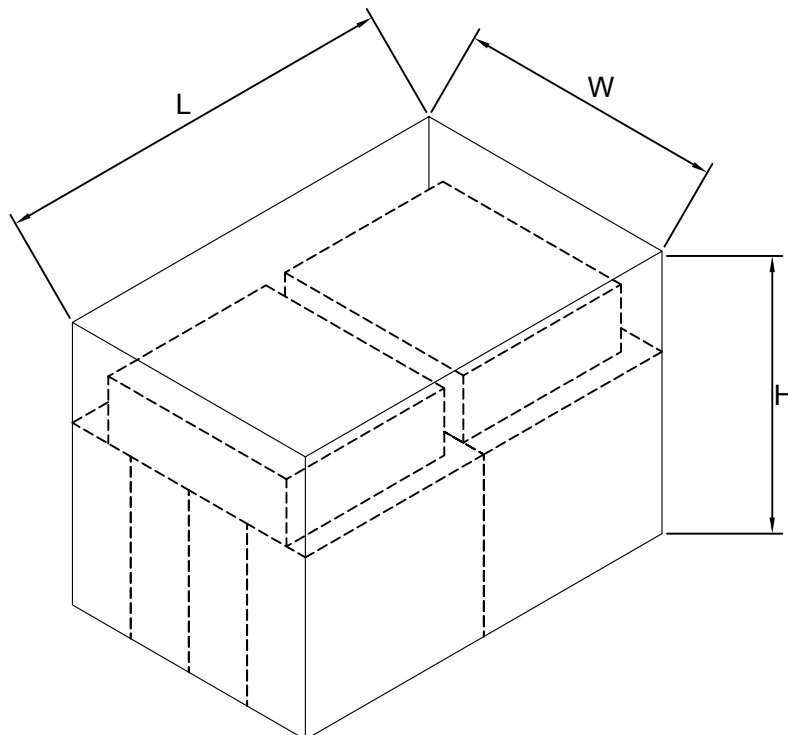

Reliability Test

(1)Test items and results

Classification	Test Item	Test Condition	Sample Size
Endurance Test	Operating Life Test	1.Ta=Under Room Temperature As Per Data Sheet Maximum Rating. 2.If=150mA 3.t=1000 hrs	22
	High Temperature Storage Test	1.Ta=100°C 2.t=1000 hrs	22
	Low Temperature Storage Test	1.Ta=-40°C 2.t=1000 hrs	22
	High Temperature High Humidity Storage Test	1.Ta=85°C 2.RH=85% 3.t=1000 hrs	22
Environmental Test	Thermal Shock Test	1.Ta=-40°C (30min) -100°C (30min) 2.total 100 cycles	22
	Reflow Soldering Test	1.T.Sol=260°C±5°C 2.Dwell Time= 10 Sec.Max.	22
	Temperature Cycling	1.100°C ~ 25°C ~ -40°C 30mins 5mins 30mins 2.100 Cycles	22

(2)Criteria for judging the damage

Item	Symbol	Test Conditions	Criteria for Judgement	
			Min.	Max.
Forward Voltage	Vf	If=150mA	-	U.S.L x1.2
Reverse Current	Ir	Vr=5V	-	U.S.L x2.0
Luminous Intensity	Iv	If=150mA	L.S.L x 0.7	-

Note:

1.U.S.L.:Upper Standard Level.

2.L.S.L.:Lower Standard Level.

Precautions For Use:

Storage time:

- 1.The operation of Temperatures and RH are : $5^{\circ}\text{C}\sim 35^{\circ}\text{C}$,RH60%.
- 2.Once the package is opened, the products should be used within a week.
Otherwise, they should be kept in a damp proof box with desiccating agent.
Considering the tape life, we suggest our customers to use our products within a year(from production date).
- 3.If opened more than one week in an atmosphere $5^{\circ}\text{C} \sim 35^{\circ}\text{C}$,RH60%, they should be treated at $60^{\circ}\text{C}\pm 5^{\circ}\text{C}$ for 15hrs.

Drive Method:

LED is a current operated device, and therefore, requires some kind of current limiting incorporated into the driver circuit. This current limiting typically takes the form of a current limiting resistor placed in series with the LED.

Consider worst case voltage variations than could occur across the current limiting resistor. The forward current should not be allowed to change by more than 40% of its desired value.

Circuit model A

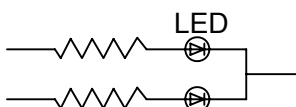

Circuit model B

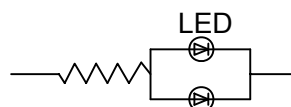

(A) Recommended circuit.

(B) The difference of brightness between LED could be found due to the VF-IF characteristics of LED.

Cleaning:

Use alcohol-based cleaning solvents such as isopropyl alcohol to clean the LED.

ESD(Electrostatic Discharge):

Static Electricity or power surge will damage the LED. Use of a conductive wrist band or anti-electrostatic glove is recommended when handling these LED. All devices, equipment and machinery must be properly grounded.