



PCF85134

Universal LCD driver for low multiplex rates

Rev. 01 — 17 December 2009

Product data sheet

1. General description

The PCF85134 is a peripheral device which interfaces to almost any LCD¹ with low multiplex rates. It generates the drive signals for any static or multiplexed LCD containing up to four backplanes and up to 60 segments. In addition, the PCF85134 can be easily cascaded for larger LCD applications. The PCF85134 is compatible with most microprocessors or microcontrollers and communicates via a two-line bidirectional I²C-bus. Communication overheads are minimized using display RAM with auto-incremented addressing, hardware subaddressing, and display memory switching (static and duplex drive modes).

2. Features

- Single-chip LCD controller and driver
- Selectable backplane drive configurations: static, 2, 3, or 4 backplane multiplexing
- 60 segment outputs allowing to drive:
 - ◆ 30 7-segment alphanumeric characters
 - ◆ 16 14-segment alphanumeric characters
 - ◆ Any graphics of up to 240 elements
- Cascading supported for larger applications
- 60 × 4-bit display data storage RAM
- Wide LCD supply range: from 2.5 V for low threshold LCDs up to 6.5 V for guest-host LCDs and high threshold twisted nematic LCDs
- Internal LCD bias generation with voltage follower buffers
- Selectable display bias configurations: static, 1/2, or 1/3
- Wide logic power supply range: from 1.8 V to 5.5 V
- LCD and logic supplies may be separated
- Low power consumption
- 400 kHz I²C-bus interface
- Compatible with any microprocessor or microcontroller
- No external components required
- Display memory bank switching in static and duplex drive mode
- Auto-incremented display data loading
- Versatile blink modes
- Silicon gate CMOS process

1. The definition of the abbreviations and acronyms used in this data sheet can be found in [Section 17](#).

3. Ordering information

Table 1. Ordering information

Type number	Package			
	Name	Description	Delivery form	Version
PCF85134HL/1	LQFP80	plastic low profile quad flat package; 80 leads; body 12 × 12 × 1.4 mm	tape and reel	SOT315-1

4. Marking

Table 2. Marking codes

Type number	Marking code
PCF85134HL/1	PCF85134HL

5. Block diagram

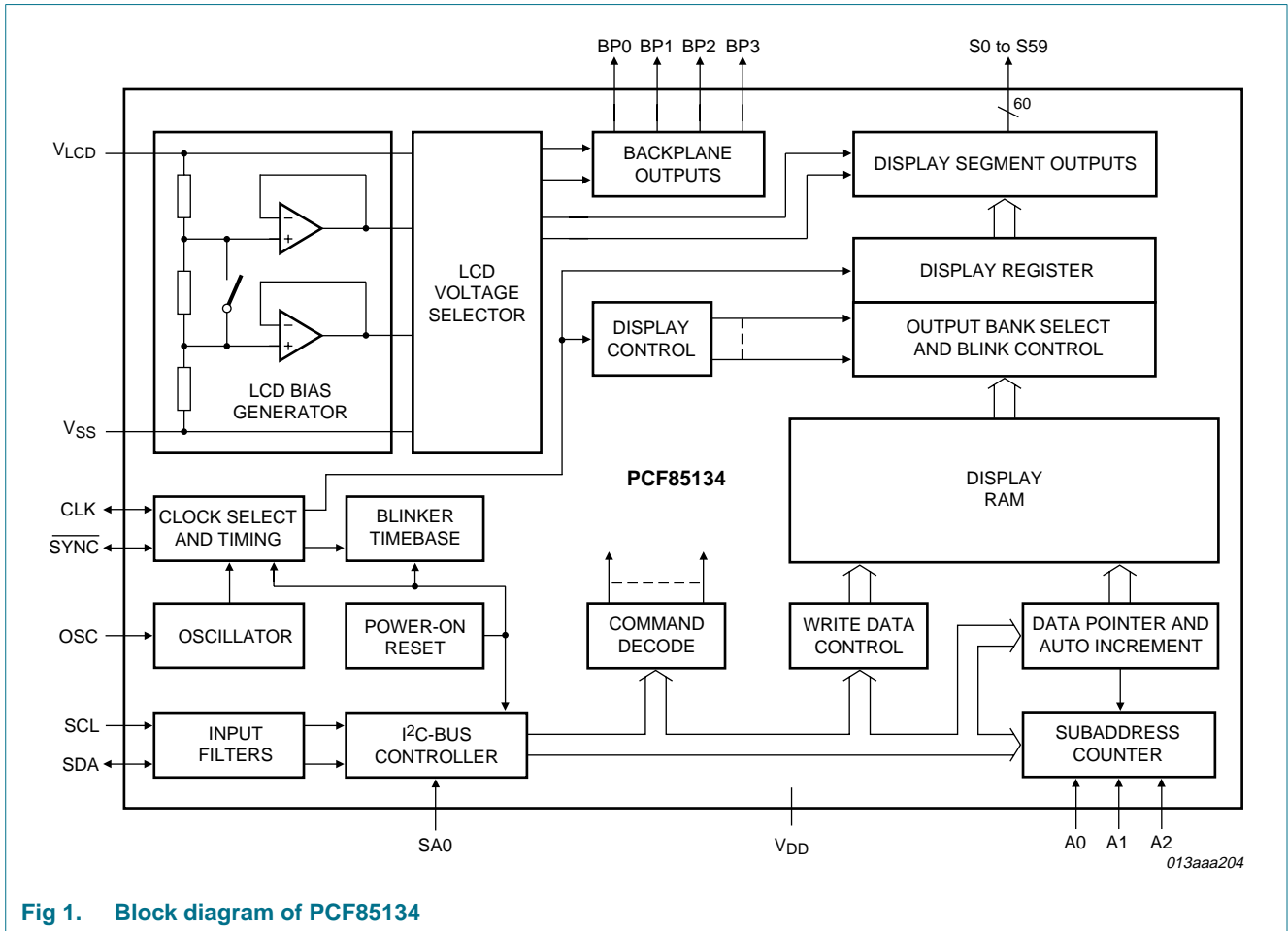
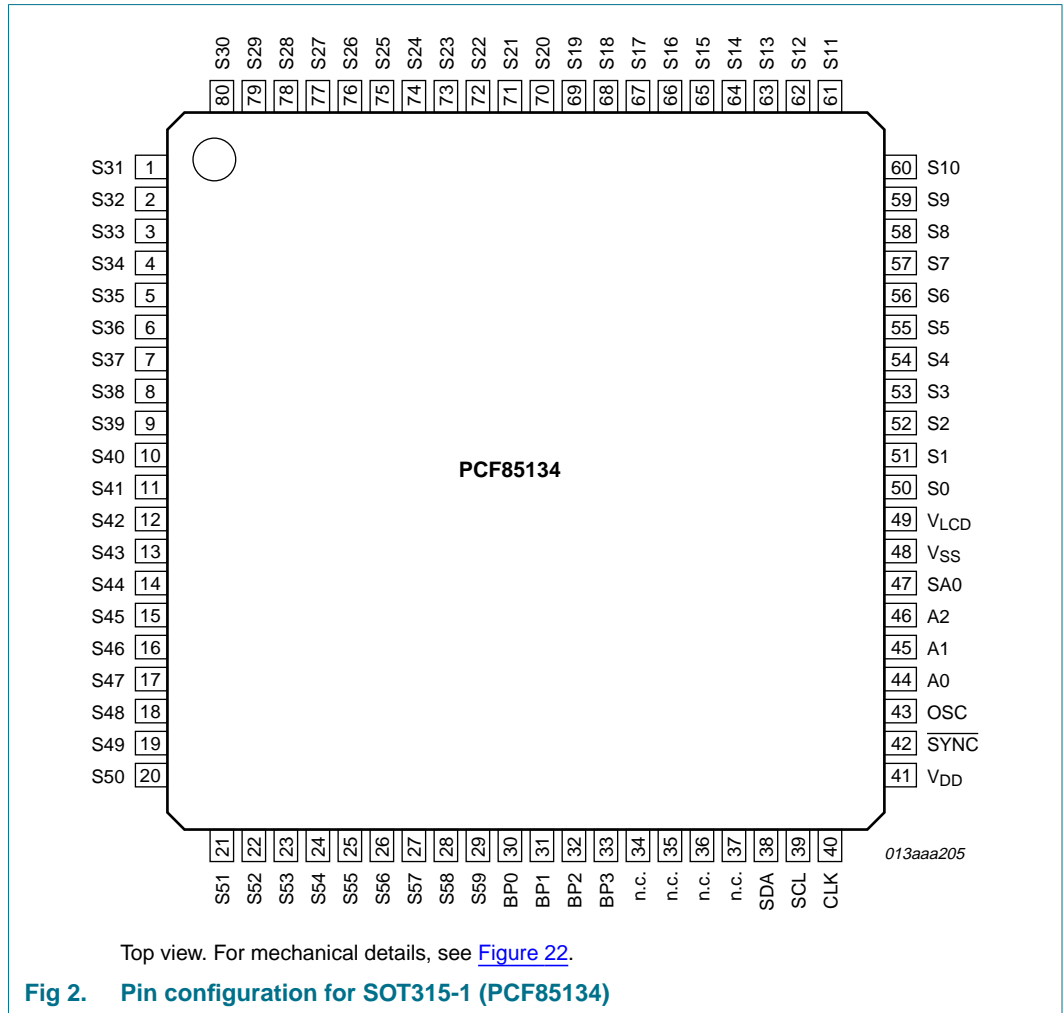

Fig 1. Block diagram of PCF85134

6. Pinning information

6.1 Pinning



6.2 Pin description

Table 3. Pin description

Symbol	Pin	Description
S31 to S59	1 to 29	LCD segment output 31 to 59
BP0 to BP3	30 to 33	LCD backplane output 0 to 3
n.c.	34 to 37	not connected
SDA	38	I ² C-bus serial data input and output
SCL	39	I ² C-bus serial clock input
CLK	40	external clock input and internal clock output
V _{DD}	41	supply voltage
SYNC	42	cascade synchronization input and output (active LOW)
OSC	43	enable input for internal oscillator
A0 to A2	44 to 46	subaddress counter input 0 to 2
SA0	47	I ² C-bus slave address input 0
V _{SS}	48	ground supply voltage
V _{LCD}	49	input of LCD supply voltage
S0 to S30	50 to 80	LCD segment output 0 to 30

7. Functional description

The PCF85134 is a versatile peripheral device designed to interface any microprocessor or microcontroller to a wide variety of LCDs. It can directly drive any static or multiplexed LCD containing up to four backplanes and up to 60 segments.

The display configurations possible with the PCF85134 depend on the number of active backplane outputs required. A selection of display configurations is shown in [Table 4](#). All of these configurations can be implemented in the typical system shown in [Figure 3](#).

Table 4. Selection of display configurations

Number of		7-segment alphanumeric		14-segment alphanumeric		Dot matrix
Backplanes	Elements	Digits	Indicator symbols	Characters	Indicator symbols	
4	240	30	30	16	16	240 (4 × 60)
3	180	22	26	12	12	180 (3 × 60)
2	120	15	15	8	8	120 (2 × 60)
1	60	7	11	4	4	60 (1 × 60)

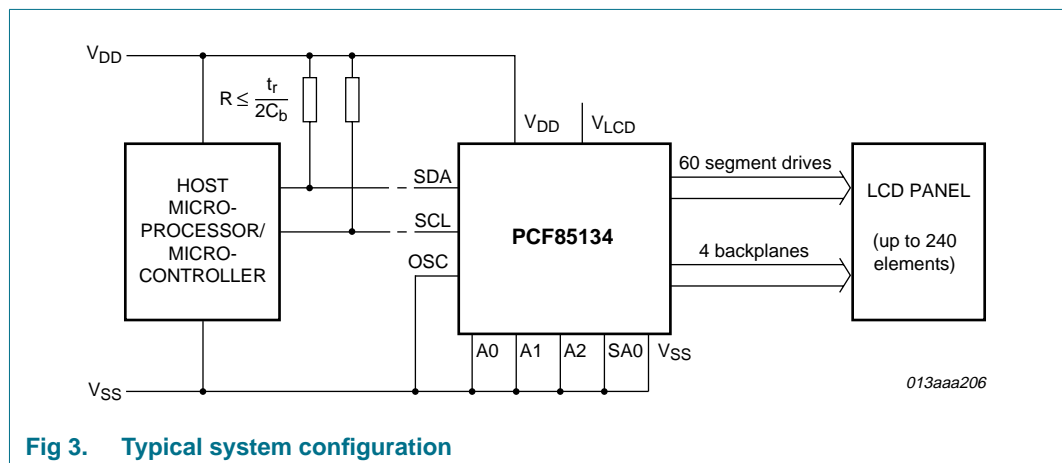

Fig 3. Typical system configuration

The host microprocessor or microcontroller maintains the 2-line I²C-bus communication channel with the PCF85134.

Biasing voltages for the multiplexed LCD waveforms are generated internally, removing the need for an external bias generator. The internal oscillator is selected by connecting pin OSC to V_{SS}. The only other connections required to complete the system are the power supplies (pins V_{DD}, V_{SS} and V_{LCD}) and the LCD panel selected for the application.

7.1 Power-On Reset (POR)

At power-on, the PCF85134 resets to the following default starting conditions:

- All backplane outputs are set to V_{LCD}
- All segment outputs are set to V_{LCD}
- The selected drive mode is: 1:4 multiplex with 1/3 bias
- Blinking is switched off
- Input and output bank selectors are reset

- The I²C-bus interface is initialized
- The data pointer and the subaddress counter are cleared (set to logic 0)
- The display is disabled

Remark: Do not transfer data on the I²C-bus for at least 1 ms after a power-on to allow the reset action to complete.

7.2 LCD bias generator

Fractional LCD biasing voltages are obtained from an internal voltage divider of three series resistors connected between pins V_{LCD} and V_{SS}. The center resistor is bypassed by switch if the 1/2 bias voltage level for the 1:2 multiplex drive mode configuration is selected.

7.3 LCD voltage selector

The LCD voltage selector coordinates the multiplexing of the LCD in accordance with the selected LCD drive configuration. The operation of the voltage selector is controlled by the mode-set command (see [Table 10](#)) from the command decoder. The biasing configurations that apply to the preferred modes of operation, together with the biasing characteristics as functions of V_{LCD} and the resulting discrimination ratios (D) are given in [Table 5](#).

Table 5. Biasing characteristics

LCD drive mode	Number of:		LCD bias configuration	$\frac{V_{off(RMS)}}{V_{LCD}}$	$\frac{V_{on(RMS)}}{V_{LCD}}$	$D = \frac{V_{on(RMS)}}{V_{off(RMS)}}$
	Backplanes	Levels				
static	1	2	static	0	1	∞
1:2 multiplex	2	3	1/2	0.354	0.791	2.236
1:2 multiplex	2	4	1/3	0.333	0.745	2.236
1:3 multiplex	3	4	1/3	0.333	0.638	1.915
1:4 multiplex	4	4	1/3	0.333	0.577	1.732

A practical value for V_{LCD} is determined by equating V_{off(RMS)} with a defined LCD threshold voltage (V_{th}), typically when the LCD exhibits approximately 10 % contrast. In the static drive mode a suitable choice is V_{LCD} > 3V_{th}.

Multiplex drive modes of 1:3 and 1:4 with 1/2 bias are possible but the discrimination and hence the contrast ratios are smaller.

Bias is calculated by $\frac{1}{1+a}$, where the values for a are

a = 1 for 1/2 bias

a = 2 for 1/3 bias

The RMS on-state voltage (V_{on(RMS)}) for the LCD is calculated with [Equation 1](#):

$$V_{on(RMS)} = V_{LCD} \sqrt{\frac{a^2 + 2a + n}{n \times (1 + a)^2}} \tag{1}$$

where the values for n are

- n = 1 for static drive mode
- n = 2 for 1:2 multiplex drive mode
- n = 3 for 1:3 multiplex drive mode
- n = 4 for 1:4 multiplex drive mode

The RMS off-state voltage ($V_{off(RMS)}$) for the LCD is calculated with [Equation 2](#):

$$V_{off(RMS)} = V_{LCD} \sqrt{\frac{a^2 - 2a + n}{n \times (1 + a)^2}} \quad (2)$$

Discrimination is the ratio of $V_{on(RMS)}$ to $V_{off(RMS)}$ and is determined from [Equation 3](#):

$$D = \frac{V_{on(RMS)}}{V_{off(RMS)}} = \sqrt{\frac{(a + 1)^2 + (n - 1)}{(a - 1)^2 + (n - 1)}} \quad (3)$$

Using [Equation 3](#), the discrimination for an LCD drive mode of 1:3 multiplex with $\frac{1}{2}$ bias is $\sqrt{3} = 1.732$ and the discrimination for an LCD drive mode of 1:4 multiplex with $\frac{1}{2}$ bias is $\frac{\sqrt{21}}{3} = 1.528$.

The advantage of these LCD drive modes is a reduction of the LCD full scale voltage V_{LCD} as follows:

- 1:3 multiplex ($\frac{1}{2}$ bias): $V_{LCD} = \sqrt{6} \times V_{off(RMS)} = 2.449V_{off(RMS)}$
- 1:4 multiplex ($\frac{1}{2}$ bias): $V_{LCD} = \left[\frac{4 \times \sqrt{3}}{3} \right] = 2.309V_{off(RMS)}$

These compare with $V_{LCD} = 3V_{off(RMS)}$ when $\frac{1}{3}$ bias is used.

It should be noted that V_{LCD} is sometimes referred as the LCD operating voltage.

7.4 LCD drive mode waveforms

7.4.1 Static drive mode

The static LCD drive mode is used when a single backplane is provided in the LCD. Backplane and segment drive waveforms for this mode are shown in [Figure 4](#).

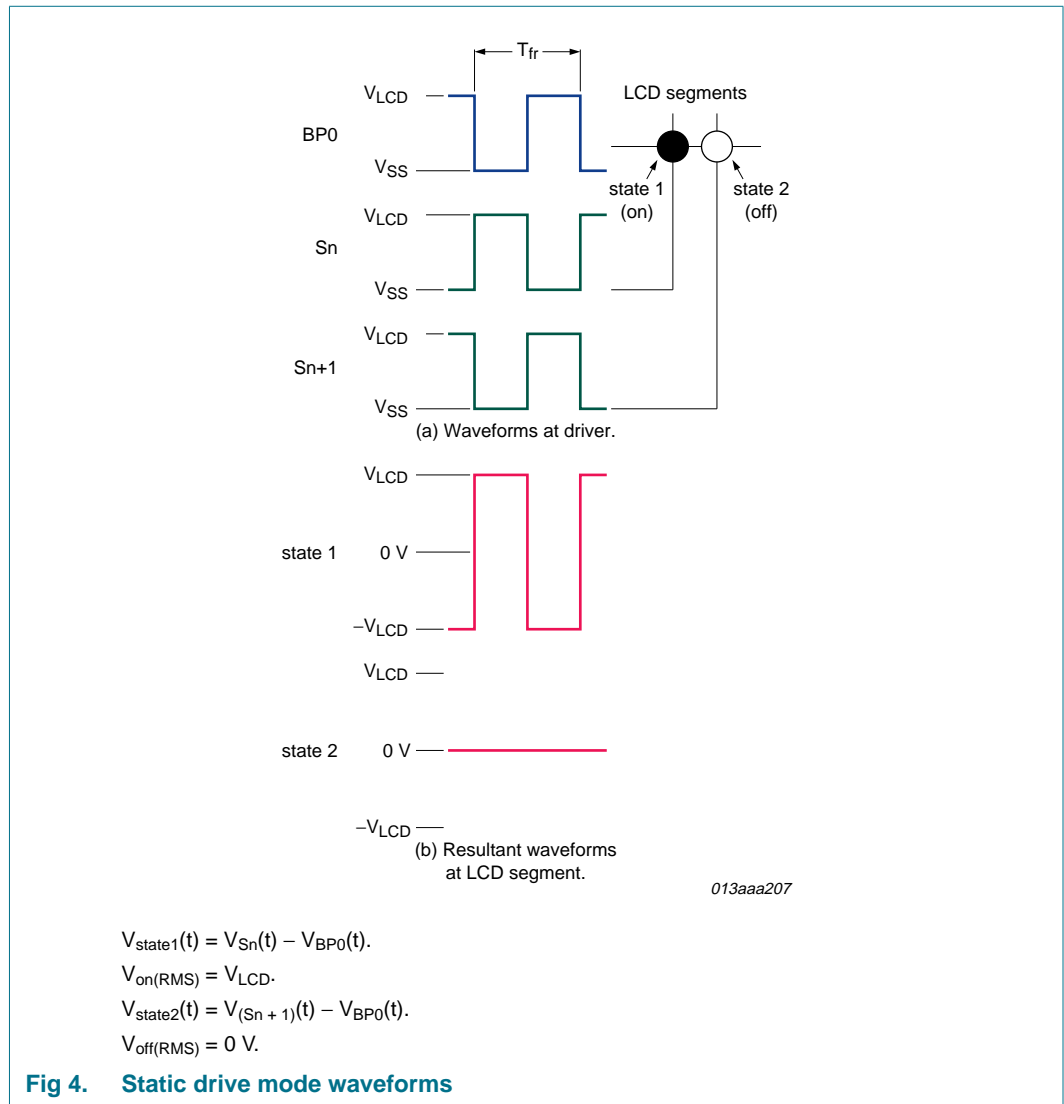

Fig 4. Static drive mode waveforms

7.4.2 1:2 Multiplex drive mode

When two backplanes are provided in the LCD, the 1:2 multiplex mode applies. The PCF85134 allows the use of 1/2 bias or 1/3 bias in this mode as shown in Figure 5 and Figure 6.

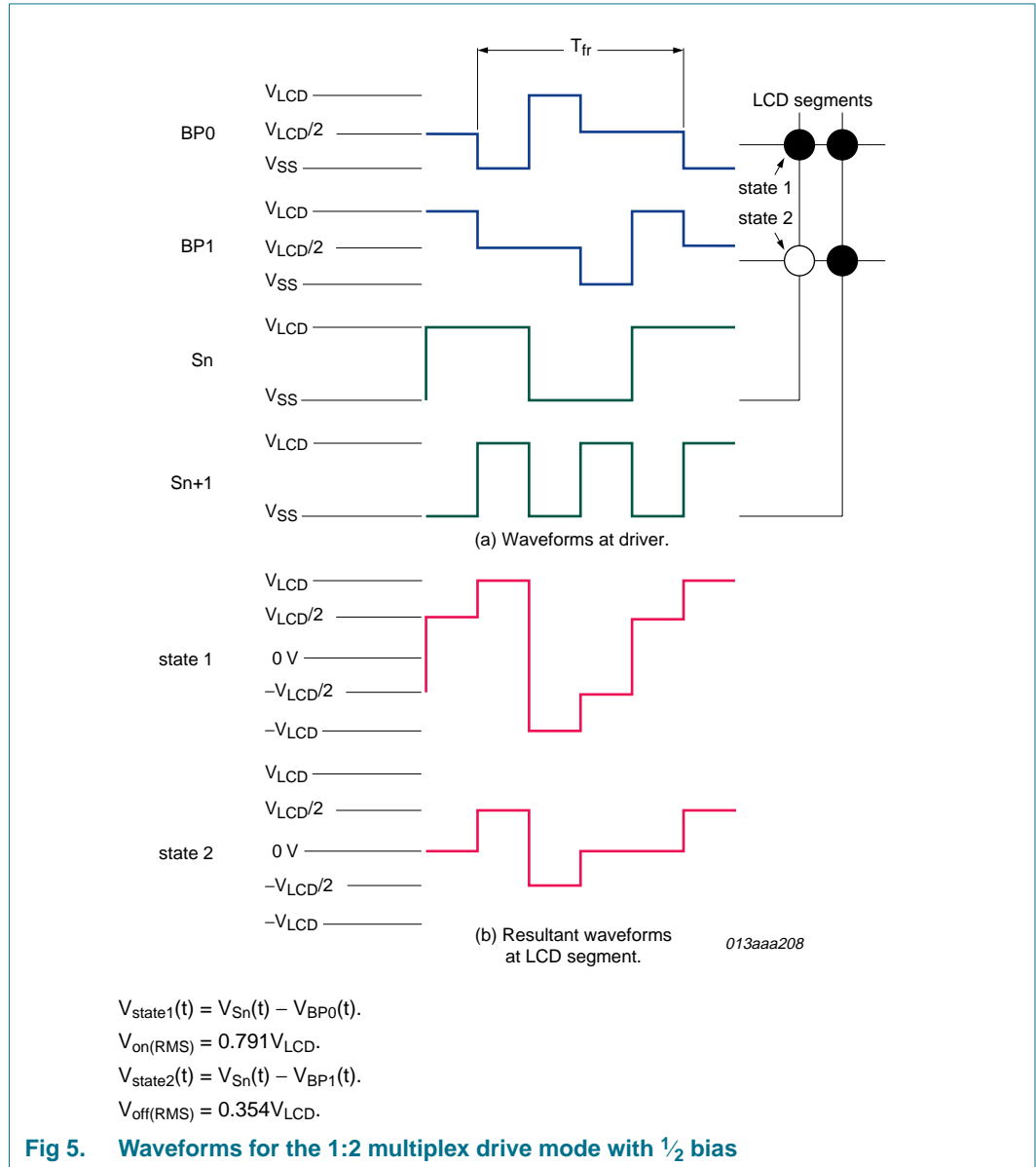

Fig 5. Waveforms for the 1:2 multiplex drive mode with 1/2 bias

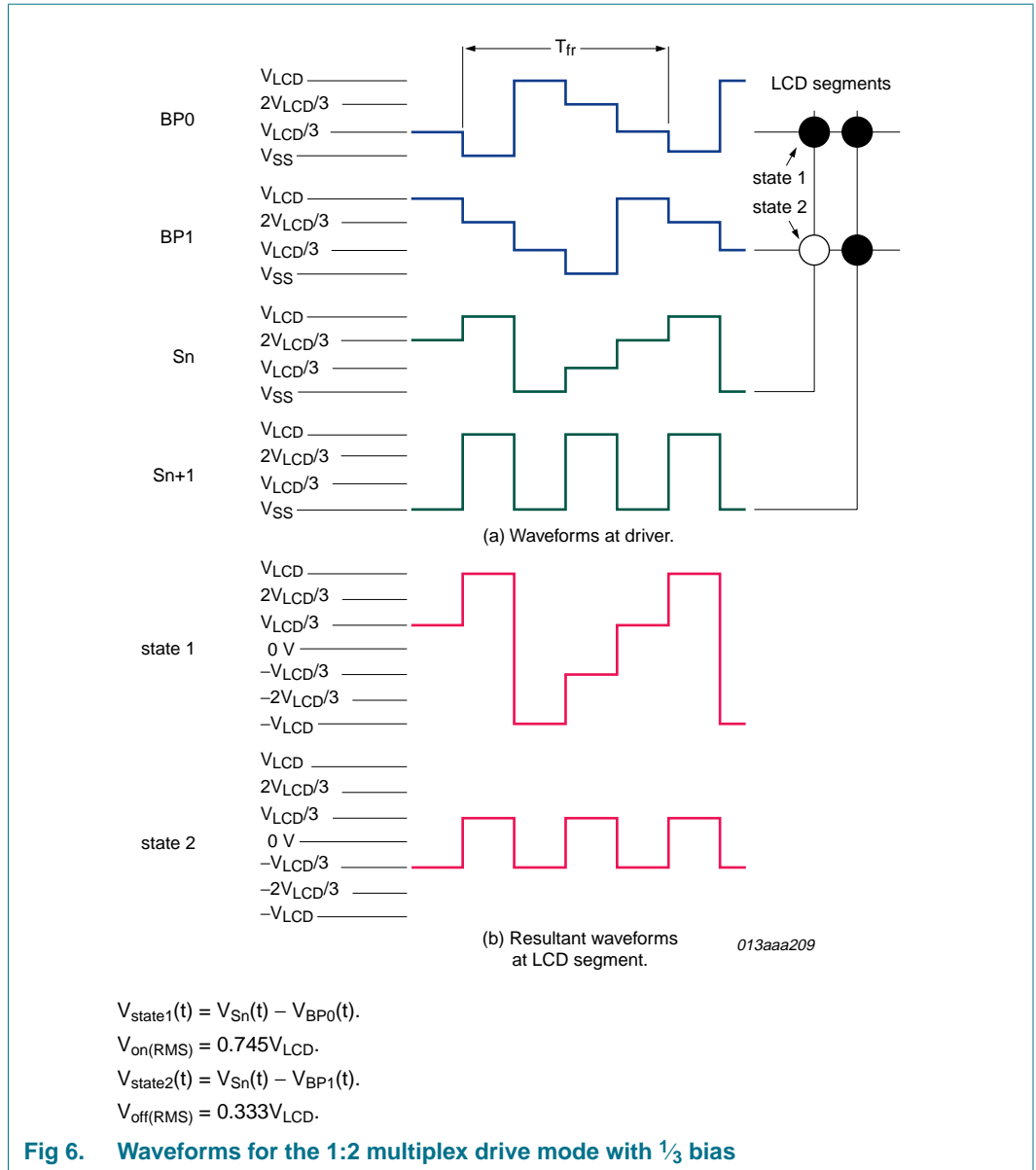
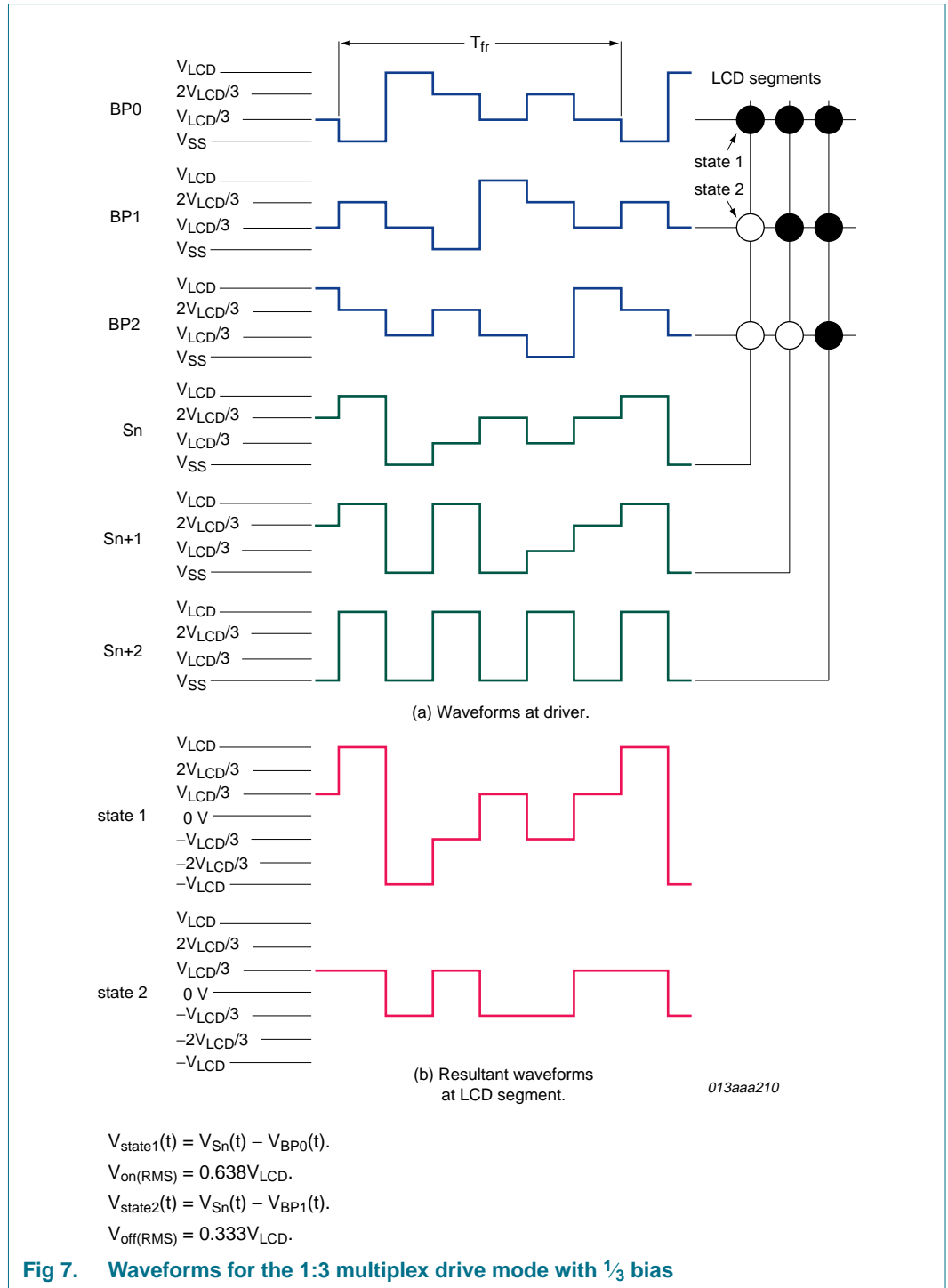

Fig 6. Waveforms for the 1:2 multiplex drive mode with 1/3 bias

7.4.3 1:3 Multiplex drive mode

When three backplanes are provided in the LCD, the 1:3 multiplex drive mode applies, as shown in Figure 7.



7.4.4 1:4 Multiplex drive mode

When four backplanes are provided in the LCD, the 1:4 multiplex drive mode applies, as shown in Figure 8.

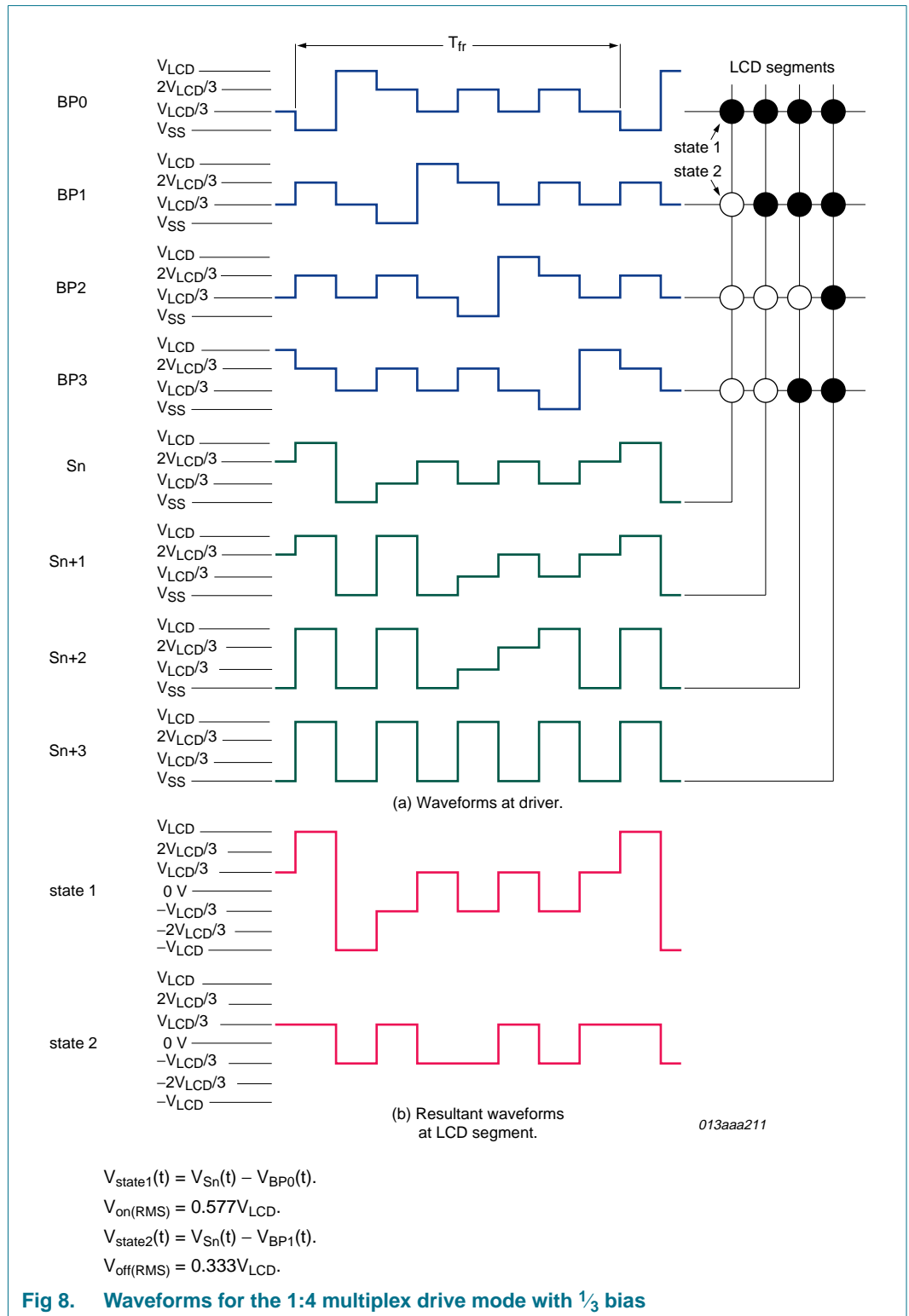

Fig 8. Waveforms for the 1:4 multiplex drive mode with 1/3 bias

7.5 Oscillator

The internal logic and the LCD drive signals of the PCF85134 are timed by the frequency f_{clk} , which equals either the built-in oscillator frequency f_{osc} or the external clock frequency $f_{clk(ext)}$. The clock frequency f_{clk} determines the LCD frame frequency (f_{fr}).

7.5.1 Internal clock

The internal oscillator is enabled by connecting pin OSC to pin V_{SS} . In this case, the output from pin CLK is the clock signal for any cascaded PCF85134 in the system.

7.5.2 External clock

Connecting pin OSC to V_{DD} enables an external clock source. Pin CLK becomes the external clock input.

A clock signal must always be supplied to the device; removing the clock may freeze the LCD in a DC state, which is not suitable for the liquid crystal.

7.6 Timing and frame frequency

The timing of the PCF85134 organizes the internal data flow of the device. This includes the transfer of display data from the display RAM to the display segment outputs. In cascaded applications, the synchronization signal (\overline{SYNC}) maintains the correct timing relationship between all the PCF85134 in the system. The timing also generates the LCD frame frequency which is derived as an integer division of the clock frequency (see [Table 6](#)). The frame frequency is a fixed division of the internal clock or of the frequency applied to pad CLK when an external clock is used.

Table 6. LCD frame frequencies

Frame frequency	Nominal frame frequency (Hz)
$f_{fr} = \frac{f_{clk}}{24}$	82

7.7 Display register

The display register holds the display data while the corresponding multiplex signals are generated. There is a one-to-one relationship between the data in the display register, the LCD segment outputs, and one column of the display RAM.

7.8 Segment outputs

The LCD drive section includes 60 segment outputs (S0 to S59) which must be connected directly to the LCD. The segment output signals are generated based on the multiplexed backplane signals and with data resident in the display register. When less than 60 segment outputs are required the unused segment outputs must be left open-circuit.

7.9 Backplane outputs

The LCD drive section includes four backplane outputs: BP0 to BP3. The backplane output signals are generated based on the selected LCD drive mode.

- In 1:4 multiplex drive mode: BP0 to BP3 must be connected directly to the LCD.

If less than four backplane outputs are required the unused outputs can be left open-circuit.

- In 1:3 multiplex drive mode: BP3 carries the same signal as BP1, therefore these two adjacent outputs can be tied together to give enhanced drive capabilities.
- In 1:2 multiplex drive mode: BP0 and BP2, BP1 and BP3 respectively carry the same signals and can also be paired to increase the drive capabilities.
- In static drive mode: The same signal is carried by all four backplane outputs; and they can be connected in parallel for very high drive requirements.

7.10 Display RAM

The display RAM is a static 60 × 4 bit RAM which stores LCD data. A logic 1 in the RAM bit map indicates the on-state of the corresponding LCD element; similarly, a logic 0 indicates the off-state. There is a one-to-one correspondence between the RAM addresses and the segment outputs and between the individual bits of a RAM word and the backplane outputs. The display RAM bit map, [Figure 9](#), shows rows 0 to 3 which correspond with the backplane outputs BP0 to BP3, and columns 0 to 59 which correspond with the segment outputs S0 to S59. In multiplexed LCD applications the segment data of the first, second, third, and fourth row of the display RAM are time-multiplexed with BP0, BP1, BP2, and BP3 respectively.

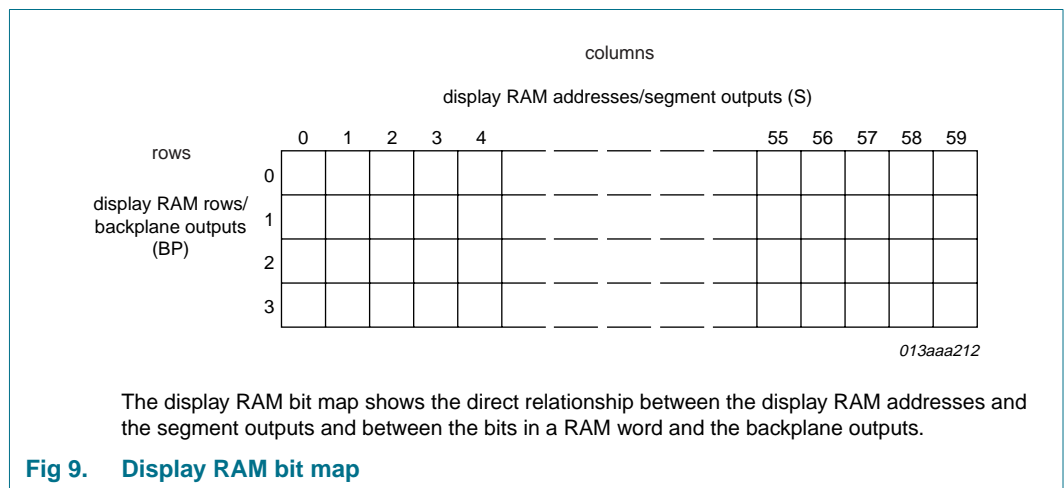

When display data is transmitted to the PCF85134, the received display bytes are stored in the display RAM in accordance with the selected LCD drive mode. The data is stored as it arrives and does not wait for the acknowledge cycle as with the commands. Depending on the current multiplex drive mode, data is stored singularly, in pairs, triples, or quadruples. To illustrate the filling order, an example of a 7-segment display showing all drive modes is given in [Figure 10](#); the RAM filling organization depicted applies equally to other LCD types.

drive mode	LCD segments	LCD backplanes	display RAM filling order	transmitted display byte																																													
static			<p>columns display RAM address/segment outputs (s) byte1</p> <table border="1"> <tr> <td>rows</td> <td>n</td> <td>n+1</td> <td>n+2</td> <td>n+3</td> <td>n+4</td> <td>n+5</td> <td>n+6</td> <td>n+7</td> </tr> <tr> <td>display RAM</td> <td>c</td> <td>b</td> <td>a</td> <td>f</td> <td>g</td> <td>e</td> <td>d</td> <td>DP</td> </tr> <tr> <td>rows/backplane</td> <td>x</td> <td>x</td> <td>x</td> <td>x</td> <td>x</td> <td>x</td> <td>x</td> <td>x</td> </tr> <tr> <td>outputs (BP)</td> <td>x</td> <td>x</td> <td>x</td> <td>x</td> <td>x</td> <td>x</td> <td>x</td> <td>x</td> </tr> <tr> <td></td> <td>3</td> <td></td> <td></td> <td></td> <td></td> <td></td> <td></td> <td></td> </tr> </table>	rows	n	n+1	n+2	n+3	n+4	n+5	n+6	n+7	display RAM	c	b	a	f	g	e	d	DP	rows/backplane	x	x	x	x	x	x	x	x	outputs (BP)	x	x	x	x	x	x	x	x		3								<p>MSB</p> <p>LSB</p> <p>c b a f g e d DP</p>
rows	n	n+1	n+2	n+3	n+4	n+5	n+6	n+7																																									
display RAM	c	b	a	f	g	e	d	DP																																									
rows/backplane	x	x	x	x	x	x	x	x																																									
outputs (BP)	x	x	x	x	x	x	x	x																																									
	3																																																
1:2 multiplex			<p>columns display RAM address/segment outputs (s) byte1</p> <table border="1"> <tr> <td>rows</td> <td>n</td> <td>n+1</td> <td>n+2</td> <td>n+3</td> </tr> <tr> <td>display RAM</td> <td>a</td> <td>f</td> <td>e</td> <td>d</td> </tr> <tr> <td>rows/backplane</td> <td>b</td> <td>g</td> <td>c</td> <td>DP</td> </tr> <tr> <td>outputs (BP)</td> <td>x</td> <td>x</td> <td>x</td> <td>x</td> </tr> <tr> <td></td> <td>3</td> <td></td> <td></td> <td></td> </tr> </table>	rows	n	n+1	n+2	n+3	display RAM	a	f	e	d	rows/backplane	b	g	c	DP	outputs (BP)	x	x	x	x		3				<p>MSB</p> <p>LSB</p> <p>a b f g e c d DP</p>																				
rows	n	n+1	n+2	n+3																																													
display RAM	a	f	e	d																																													
rows/backplane	b	g	c	DP																																													
outputs (BP)	x	x	x	x																																													
	3																																																
1:3 multiplex			<p>columns display RAM address/segment outputs (s) byte1</p> <table border="1"> <tr> <td>rows</td> <td>n</td> <td>n+1</td> <td>n+2</td> </tr> <tr> <td>display RAM</td> <td>b</td> <td>a</td> <td>f</td> </tr> <tr> <td>rows/backplane</td> <td>DP</td> <td>d</td> <td>e</td> </tr> <tr> <td>outputs (BP)</td> <td>c</td> <td>g</td> <td>x</td> </tr> <tr> <td></td> <td>3</td> <td></td> <td></td> </tr> </table>	rows	n	n+1	n+2	display RAM	b	a	f	rows/backplane	DP	d	e	outputs (BP)	c	g	x		3			<p>MSB</p> <p>LSB</p> <p>b DP c a d g f e</p>																									
rows	n	n+1	n+2																																														
display RAM	b	a	f																																														
rows/backplane	DP	d	e																																														
outputs (BP)	c	g	x																																														
	3																																																
1:4 multiplex			<p>columns display RAM address/segment outputs (s) byte1</p> <table border="1"> <tr> <td>rows</td> <td>n</td> <td>n+1</td> </tr> <tr> <td>display RAM</td> <td>a</td> <td>f</td> </tr> <tr> <td>rows/backplane</td> <td>c</td> <td>e</td> </tr> <tr> <td>outputs (BP)</td> <td>b</td> <td>g</td> </tr> <tr> <td></td> <td>DP</td> <td>d</td> </tr> <tr> <td></td> <td>3</td> <td></td> </tr> </table>	rows	n	n+1	display RAM	a	f	rows/backplane	c	e	outputs (BP)	b	g		DP	d		3		<p>MSB</p> <p>LSB</p> <p>a c b DP f e g d</p>																											
rows	n	n+1																																															
display RAM	a	f																																															
rows/backplane	c	e																																															
outputs (BP)	b	g																																															
	DP	d																																															
	3																																																

001aaJ646

x = data bit unchanged.

Fig 10. Relationship between LCD layout, drive mode, display RAM storage order and display data transmitted over the I²C-bus

The following applies to [Figure 10](#):

- In static drive mode the eight transmitted data bits are placed into row 0 of eight successive 4-bit RAM words.
- In 1:2 multiplex mode the eight transmitted data bits are placed in pairs into row 0 and 1 of four successive 4-bit RAM words.
- In 1:3 multiplex mode the eight bits are placed in triples into row 0, 1, and 2 of three successive 4-bit RAM words, with bit 3 of the third address left unchanged. It is not recommended to use this bit in a display because of the difficult addressing. This last bit may, if necessary, be controlled by an additional transfer to this address, but care should be taken to avoid overwriting adjacent data because always full bytes are transmitted.
- In the 1:4 multiplex mode the eight transmitted data bits are placed in quadruples into row 0, 1, 2, and 3 of two successive 4-bit RAM words.

7.11 Data pointer

The addressing mechanism for the display RAM is realized using the data pointer. This allows the loading of an individual display data byte, or a series of display data bytes, into any location of the display RAM. The sequence commences with the initialization of the data pointer by the load-data-pointer command (see [Table 9](#)). Following this command, an arriving data byte is stored at the display RAM address indicated by the data pointer. The filling order is shown in [Figure 10](#). After each byte is stored, the content of the data pointer is automatically incremented by a value dependent on the selected LCD drive mode:

- In static drive mode by eight.
- In 1:2 multiplex drive mode by four.
- In 1:3 multiplex drive mode by three.
- In 1:4 multiplex drive mode by two.

If an I²C-bus data access terminates early, the state of the data pointer is unknown. Consequently, the data pointer must be rewritten prior to further RAM accesses.

7.12 Subaddress counter

The storage of display data is conditioned by the content of the subaddress counter. Storage is allowed only when the content of the subaddress counter match with the hardware subaddress applied to A0, A1 and A2. The subaddress counter value is defined by the device-select command (see [Table 12](#)). If the content of the subaddress counter and the hardware subaddress do not match, then data storage is inhibited but the data pointer is incremented as if data storage had taken place. The subaddress counter is also incremented when the data pointer overflows.

In cascaded applications each PCF85134 in the cascade must be addressed separately. Initially, the first PCF85134 is selected by sending the device-select command matching the first device's hardware subaddress. Then the data pointer is set to the preferred display RAM address by sending the load-data-pointer command.

Once the display RAM of the first PCF85134 has been written, the second PCF85134 is selected by sending the device-select command again. This time however the command matches the second device's hardware subaddress. Next the load-data-pointer command is sent to select the preferred display RAM address of the second PCF85134.

This last step is very important because during writing data to the first PCF85134, the data pointer of the second PCF85134 is incremented. In addition, the hardware subaddress should not be changed whilst the device is being accessed on the I²C-bus interface.

7.13 Output bank selector

The output bank selector (see [Table 13](#)) selects one of the four rows per display RAM address for transfer to the display register. The actual row selected depends on the particular LCD drive mode in operation and on the instant in the multiplex sequence.

- In 1:4 multiplex mode, all RAM addresses of row 0 are selected, these are followed by the contents of row 1, 2, and then 3
- In 1:3 multiplex mode, rows 0, 1, and 2 are selected sequentially
- In 1:2 multiplex mode, rows 0 and 1 are selected
- In static mode, row 0 is selected

The $\overline{\text{SYNC}}$ signal resets these sequences to the following starting points: bit 3 for 1:4 multiplex, bit 2 for 1:3 multiplex, bit 1 for 1:2 multiplex, and bit 0 for static mode.

The PCF85134 includes a RAM bank switching feature in the static and 1:2 multiplex drive modes. In the static drive mode, the bank-select command may request the contents of row 2 to be selected for display instead of the contents of row 0. In the 1:2 mode, the contents of rows 2 and 3 may be selected instead of rows 0 and 1. This gives the provision for preparing display information in an alternative bank and to be able to switch to it, once it is assembled.

7.14 Input bank selector

The input bank selector loads display data into the display RAM in accordance with the selected LCD drive configuration. Display data can be loaded in row 2 in static drive mode or in rows 2 and 3 in 1:2 multiplex drive mode by using the bank-select command. The input bank selector functions independently to the output bank selector.

7.15 Blinker

The display blink capabilities of the PCF85134 are very versatile. The whole display can blink at frequencies selected by the blink-select command (see [Table 14](#)). The blink frequencies are fractions of the clock frequency. The ratios between the clock and blink frequencies depend on the blink mode selected (see [Table 7](#)).

Table 7. Blink frequencies

Blink mode	Operating mode ratio	Blink frequency with respect to f_{clk} (typical)	Unit
		$f_{clk} = 1.970 \text{ kHz}$	
off	-	blinking off	Hz
1	$\frac{f_{clk}}{768}$	2.5	Hz
2	$\frac{f_{clk}}{1536}$	1.3	Hz
3	$\frac{f_{clk}}{3072}$	0.6	Hz

An additional feature is for an arbitrary selection of LCD segments to blink. This applies to the static and 1:2 multiplex drive modes and can be implemented without any communication overheads. By means of the output bank selector, the displayed RAM banks are exchanged with alternate RAM banks at the blink frequency. This mode can also be specified by the blink-select command.

In the 1:3 and 1:4 multiplex modes, where no alternate RAM bank is available, groups of LCD segments can blink by selectively changing the display RAM data at fixed time intervals.

The entire display can blink at a frequency other than the nominal blink frequency. This can be effectively performed by resetting and setting the display enable bit E at the required rate using the mode-set command (see [Table 10](#)).

8. Basic architecture

8.1 Characteristics of the I²C-bus

The I²C-bus is for bidirectional, two-line communication between different ICs or modules. The two lines are a Serial Data line (SDA) and a Serial Clock Line (SCL). Both lines must be connected to a positive supply via a pull-up resistor when connected to the output stages of a device. Data transfer may be initiated only when the bus is not busy.

8.1.1 Bit transfer

One data bit is transferred during each clock pulse. The data on the SDA line must remain stable during the HIGH period of the clock pulse as changes in the data line at this time will be interpreted as a control signal. Bit transfer is illustrated in [Figure 11](#).

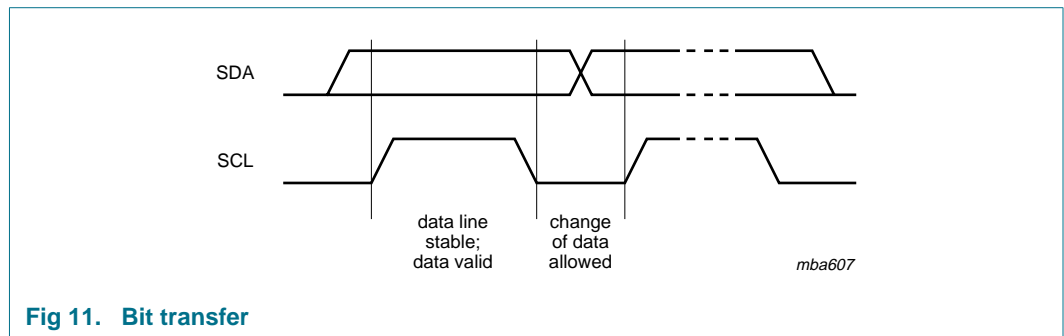

Fig 11. Bit transfer

8.1.1.1 START and STOP conditions

Both data and clock lines remain HIGH when the bus is not busy.

A HIGH-to-LOW change of the data line, while the clock is HIGH, is defined as the START condition (S).

A LOW-to-HIGH change of the data line, while the clock is HIGH, is defined as the STOP condition (P).

The START and STOP conditions are illustrated in [Figure 12](#).

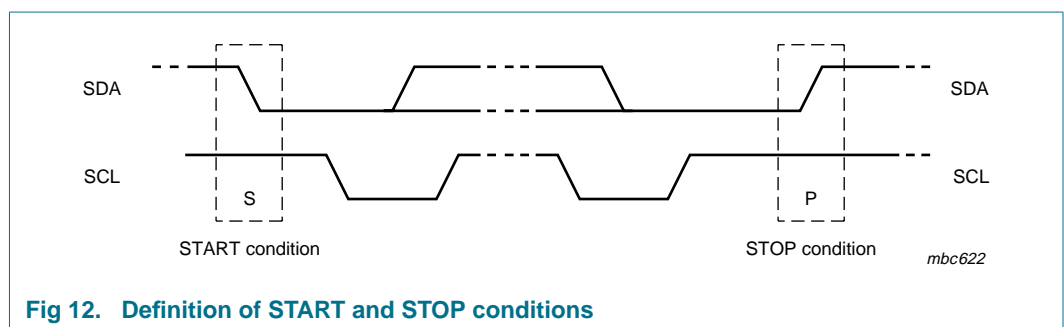

Fig 12. Definition of START and STOP conditions

8.1.2 System configuration

A device generating a message is a transmitter, a device receiving a message is the receiver. The device that controls the message is the master; and the devices which are controlled by the master are the slaves. The system configuration is shown in [Figure 13](#).

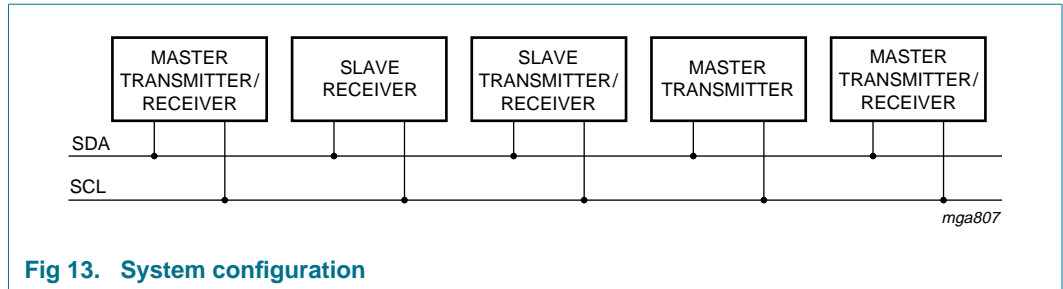

Fig 13. System configuration

8.1.3 Acknowledge

The number of data bytes transferred between the START and STOP conditions from transmitter to receiver is unlimited. Each byte of eight bits is followed by an acknowledge cycle.

- A slave receiver, which is addressed, must generate an acknowledge after the reception of each byte.
- A master receiver must generate an acknowledge after the reception of each byte that has been clocked out of the slave transmitter.
- The device that acknowledges must pull-down the SDA line during the acknowledge clock pulse, so that the SDA line is stable LOW during the HIGH period of the acknowledge related clock pulse (set-up and hold times must be taken into consideration).
- A master receiver must signal an end of data to the transmitter by not generating an acknowledge on the last byte that has been clocked out of the slave. In this event, the transmitter must leave the data line HIGH to enable the master to generate a STOP condition.

Acknowledgement on the I²C-bus is illustrated in [Figure 14](#).

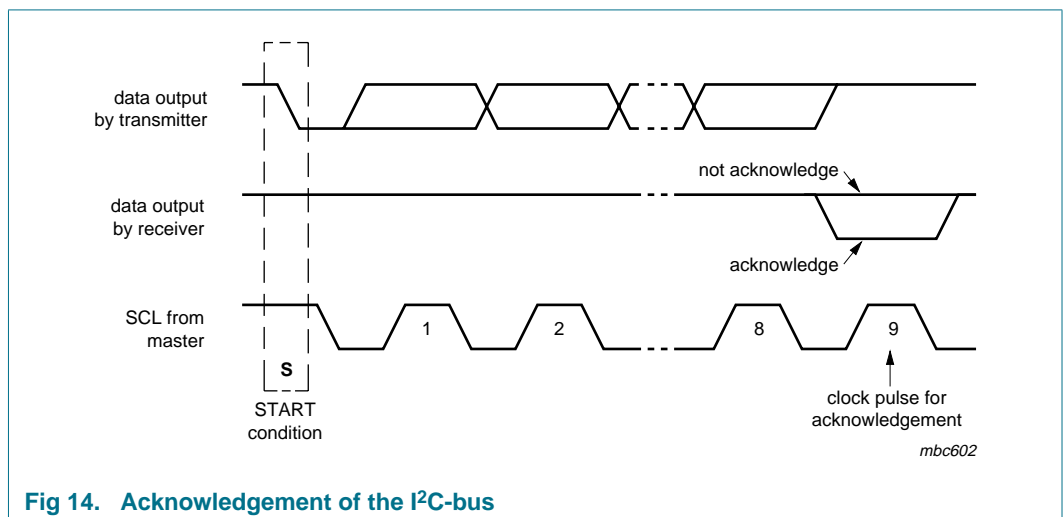

Fig 14. Acknowledgement of the I²C-bus

8.1.4 I²C-bus controller

The PCF85134 acts as an I²C-bus slave receiver. It does not initiate I²C-bus transfers or transmit data to an I²C-bus master receiver. The only data output from the PCF85134 are the acknowledge signals of the selected devices. Device selection depends on the I²C-bus slave address, the transferred command data and the hardware subaddress.

In single device applications, the hardware subaddress inputs A0, A1, and A2 are normally tied to V_{SS} which defines the hardware subaddress 0. In multiple device applications A0, A1, and A2 are tied to V_{SS} or V_{DD} using a binary coding scheme, so that no two devices with a common I²C-bus slave address have the same hardware subaddress.

8.1.5 Input filters

To enhance noise immunity in electrically adverse environments, RC low-pass filters are provided on the SDA and SCL lines.

8.2 I²C-bus protocol

Two I²C-bus slave addresses (0111 000 and 0111 001) are reserved for the PCF85134. The least significant bit of the slave address is bit R/ \overline{W} . The PCF85134 is a write-only device. It will not respond to a read access, so this bit should always be logic 0. The second bit of the slave address is defined by the level tied at input SA0. Two displays controlled by PCF85134 can be recognized on the same I²C-bus which allows:

- Up to 16 PCF85134s on the same I²C-bus for very large LCD applications
- The use of two types of LCD multiplex drive mode on the same I²C-bus

The I²C-bus protocol is shown in [Figure 15](#). The sequence is initiated with a START condition (S) from the I²C-bus master which is followed by one of the available PCF85134 slave addresses. All PCF85134s with the same SA0 level acknowledge in parallel to the slave address. All PCF85134s with the alternative SA0 level ignore the whole I²C-bus transfer.

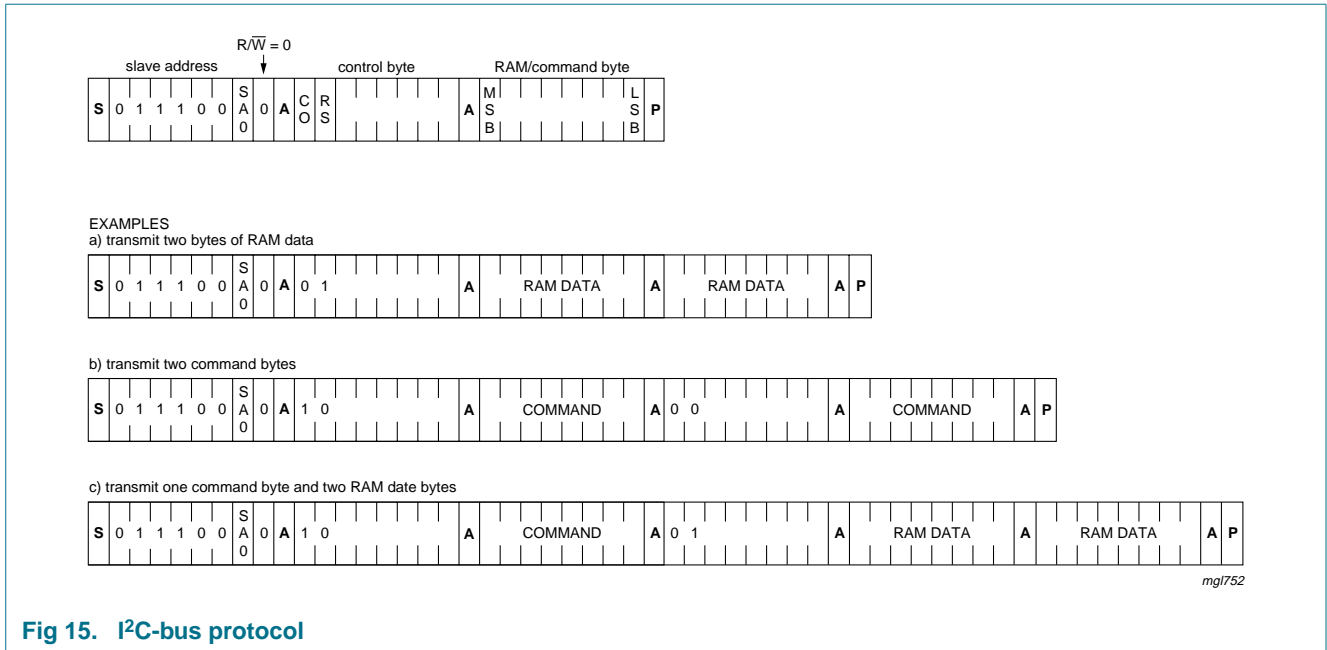

Fig 15. I²C-bus protocol

After acknowledgement, the control byte is sent defining if the next byte is a RAM or command information. The control byte also defines if the next byte is a control byte or further RAM or command data (see Figure 16 and Table 8). In this way it is possible to configure the device and then fill the display RAM with little overhead.

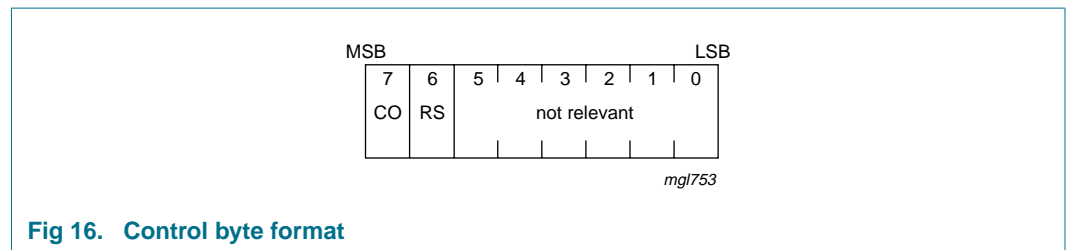

Fig 16. Control byte format

Table 8. Control byte description

Bit	Symbol	Value	Description
7	CO		continue bit
		0	last control byte
		1	control bytes continue
6	RS		register selection
		0	command register
		1	data register
5 to 0	-		not relevant

The command bytes and control bytes are also acknowledged by all addressed PCF85134s connected to the bus.

The display bytes are stored in the display RAM at the address specified by the data pointer and the subaddress counter. Both data pointer and subaddress counter are automatically updated.

The acknowledgement after each byte is made only by the (A0, A1, and A2) addressed PCF85134. After the last display byte, the I²C-bus master issues a STOP condition (P). Alternatively a START may be issued to RESTART I²C-bus access.

8.3 Command decoder

The command decoder identifies command bytes that arrive on the I²C-bus. There are five commands:

Table 9. Definition of commands

Command	Operation code								Reference
	7	6	5	4	3	2	1	0	
Mode-set	1	1	0	0	E	B	M[1:0]		Table 10
Load-data-pointer	0	P[6:0]							Table 11
Device-select	1	1	1	0	0	A[2:0]			Table 12
Bank-select	1	1	1	1	1	0	I	O	Table 13
Blink-select	1	1	1	1	0	A	BF[1:0]		Table 14

Table 10. Mode-set command bit description

Bit	Symbol	Value	Description
7 to 4	-	1100	fixed value
3	E		display status
		0	disabled (blank) ^[1]
		1	enable
2	B		LCD bias configuration
		0	1/3 bias
		1	1/2 bias
1 to 0	M[1:0]		LCD drive mode selection
		01	static; 1 backplane
		10	1:2 multiplex; 2 backplanes
		11	1:3 multiplex; 3 backplanes
		00	1:4 multiplex; 4 backplanes

[1] The possibility to disable the display allows implementation of blinking under external control.

Table 11. Load-data-pointer command bit description

See [Section 7.11](#).

Bit	Symbol	Value	Description
7	-	0	fixed value
6 to 0	P[6:0]	0000000 to 0111011	7-bit binary value of 0 to 59

Table 12. Device-select command bit description

See [Section 7.12](#).

Bit	Symbol	Value	Description
7 to 3	-	11100	fixed value
2 to 0	A[2:0]	000 to 111	3-bit binary value of 0 to 7

Table 13. Bank-select command bit description

See [Section 7.10](#), [Section 7.11](#), [Section 7.12](#), [Section 7.13](#) and [Section 7.14](#).

Bit	Symbol	Value	Description	
			Static	1:2 multiplex ^[1]
7 to 2	-	111110	fixed value	
1	I		input bank selection: storage of arriving display data	
		0	RAM row 0	RAM rows 0 and 1
		1	RAM row 2	RAM rows 2 and 3
0	O		output bank selection: retrieval of LCD display data	
		0	RAM row 0	RAM rows 0 and 1
		1	RAM row 2	RAM rows 2 and 3

[1] The bank-select command has no effect in 1:3 or 1:4 multiplex drive modes.

Table 14. Blink-select command bit description

See [Section 7.15](#).

Bit	Symbol	Value	Description
7 to 3	-	11110	fixed value
2	A		blink mode selection
		0	normal blinking ^[1]
		1	blinking by alternating display RAM banks
1 to 0	BF[1:0]		blink frequency selection
		00	off
		01	1
		10	2
		11	3

[1] Normal blinking can only be selected in multiplex drive mode 1:3 or 1:4.

[2] For the blink frequencies, see [Table 7](#).

8.4 Display controller

The display controller executes the commands identified by the command decoder. It contains the status registers of the PCF85134 and coordinates their effects. The controller also loads display data into the display RAM as required by the storage order.

9. Internal circuitry

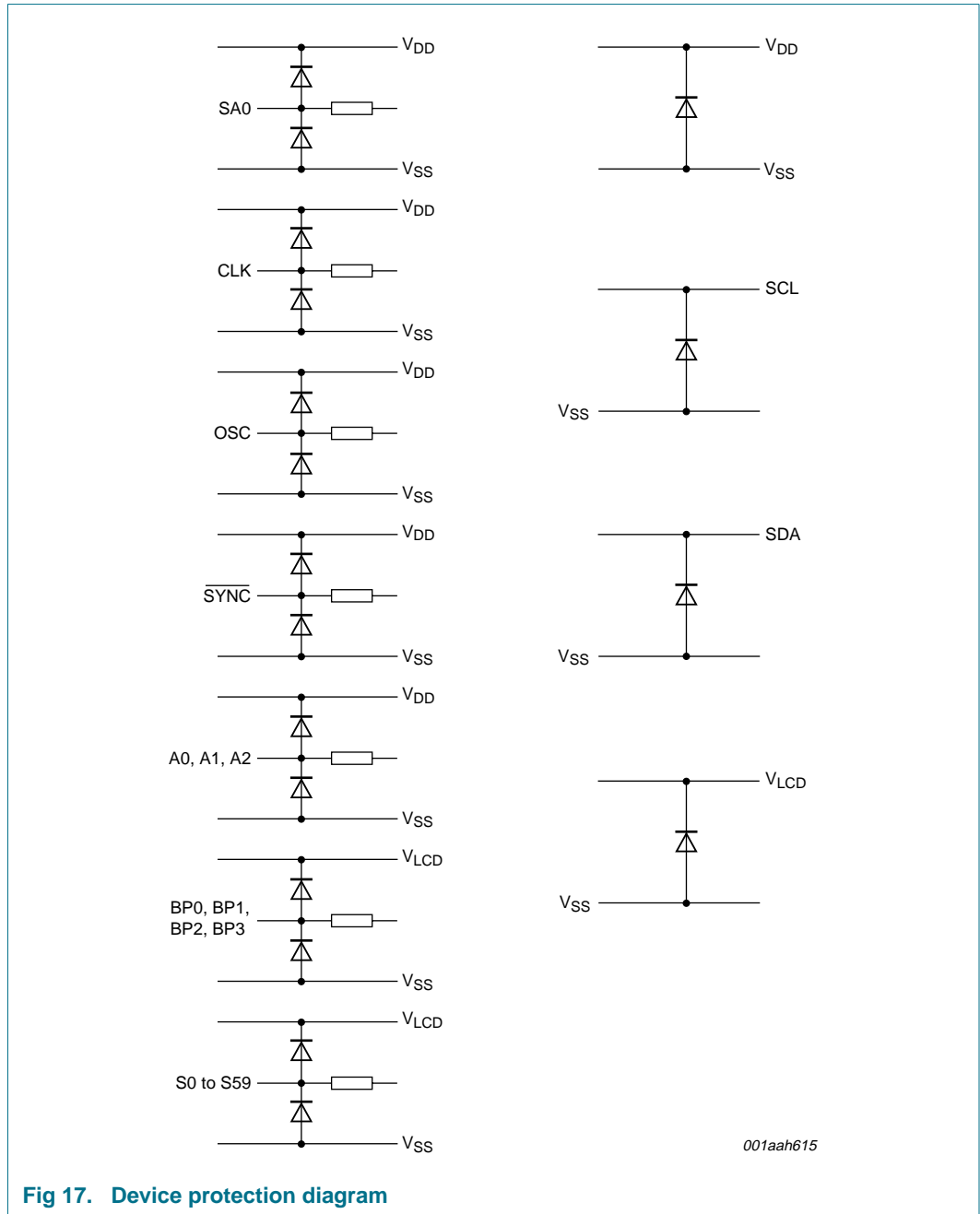

Fig 17. Device protection diagram

10. Limiting values

CAUTION



Static voltages across the liquid crystal display can build up when the LCD supply voltage (V_{LCD}) is on while the IC supply voltage (V_{DD}) is off, or vice versa. This may cause unwanted display artifacts. To avoid such artifacts, V_{LCD} and V_{DD} must be applied or removed together.

Table 15. Limiting values

In accordance with the Absolute Maximum Rating System (IEC 60134).^[1]

Symbol	Parameter	Conditions	Min	Max	Unit
V_{DD}	supply voltage		-0.5	+6.5	V
I_{DD}	supply current		-50	+50	mA
V_{LCD}	LCD supply voltage		-0.5	+7.5	V
$I_{DD(LCD)}$	LCD supply current		-50	+50	mA
I_{SS}	ground supply current		-50	+50	mA
V_I	input voltage		[2] -0.5	+6.5	V
I_I	input current		[2] -10	+10	mA
V_O	output voltage		[2] -0.5	+6.5	V
			[3] -0.5	+7.5	V
I_O	output current		[2][3] -10	+10	mA
P_{tot}	total power dissipation		-	400	mW
P/out	power dissipation per output		-	100	mW
V_{ESD}	electrostatic discharge voltage	HBM	[4] -	±2500	V
		MM	[5] -	±200	V
I_{lu}	latch-up current		[6] -	200	mA
T_{stg}	storage temperature		[7] -65	+150	°C

[1] Stresses above these values listed may cause permanent damage to the device.

[2] Pins SDA, SCL, CLK, \overline{SYNC} , SA0, OSC and A0 to A2.

[3] Pins S0 to S59 and BP0 to BP3.

[4] HBM: Human Body Model, according to [Ref. 5 "JESD22-A114"](#).

[5] MM: Machine Model, according to [Ref. 6 "JESD22-A115"](#).

[6] Pass level; latch-up testing according to [Ref. 7 "JESD78"](#) at maximum ambient temperature ($T_{amb(max)} = +85\text{ °C}$).

[7] According to the NXP store and transport requirements (see [Ref. 9 "NX3-00092"](#)) the devices have to be stored at a temperature of +8 °C to +45 °C and a humidity of 25 % to 75 %. For long term storage products deviant conditions are described in that document.

11. Static characteristics

Table 16. Static characteristics

$V_{DD} = 1.8\text{ V to }5.5\text{ V}$; $V_{SS} = 0\text{ V}$; $V_{LCD} = 2.5\text{ V to }6.5\text{ V}$; $T_{amb} = -40\text{ }^{\circ}\text{C to }+85\text{ }^{\circ}\text{C}$; unless otherwise specified.

Symbol	Parameter	Conditions	Min	Typ	Max	Unit	
Supplies							
V_{DD}	supply voltage		1.8	-	5.5	V	
V_{LCD}	LCD supply voltage		2.5	-	6.5	V	
I_{DD}	supply current	$f_{clk(ext)} = 1536\text{ Hz}$	[1]	-	8	μA	
$I_{DD(LCD)}$	LCD supply current	$f_{clk(ext)} = 1536\text{ Hz}$	[1]	-	24	μA	
Logic							
V_I	input voltage		$V_{SS} - 0.5$	-	$V_{DD} + 0.5$	V	
V_{IL}	LOW-level input voltage	on pins CLK, $\overline{\text{SYNC}}$, OSC, A0 to A2 and SA0	V_{SS}	-	$0.3V_{DD}$	V	
V_{IH}	HIGH-level input voltage	on pins CLK, $\overline{\text{SYNC}}$, OSC, A0 to A2 and SA0	$0.7V_{DD}$	-	V_{DD}	V	
V_{POR}	power-on reset voltage		1.0	1.3	1.6	V	
I_{OL}	LOW-level output current	output sink current; $V_{OL} = 0.4\text{ V}$; $V_{DD} = 5\text{ V}$; on pins CLK and $\overline{\text{SYNC}}$	1	-	-	mA	
I_{OH}	HIGH-level output current	output source current; $V_{OH} = 4.6\text{ V}$; $V_{DD} = 5\text{ V}$; on pin CLK	1	-	-	mA	
I_L	leakage current	$V_I = V_{DD}$ or V_{SS} ; on pins SA0, A0 to A2 and CLK	-1	-	+1	μA	
		$V_I = V_{DD}$; on pin OSC	-1	-	+1	μA	
C_I	input capacitance		[2]	-	7	pF	
I²C-bus; pins SDA and SCL							
V_I	input voltage		$V_{SS} - 0.5$	-	5.5	V	
V_{IL}	LOW-level input voltage	pin SCL	V_{SS}	-	$0.3V_{DD}$	V	
		pin SDA	V_{SS}	-	$0.2V_{DD}$	V	
V_{IH}	HIGH-level input voltage		$0.7V_{DD}$	-	5.5	V	
I_{OL}	LOW-level output current	output sink current; $V_{OL} = 0.4\text{ V}$; $V_{DD} = 5\text{ V}$; on pin SDA	3	-	-	mA	
I_L	leakage current	$V_I = V_{DD}$ or V_{SS}	-1	-	+1	μA	
C_i	input capacitance		[2]	-	7	pF	
LCD outputs							
Output pins BP0 to BP3							
V_{BP}	voltage on pin BP	$C_{bpl} = 35\text{ nF}$	[3]	-100	-	+100	mV
R_{BP}	resistance on pin BP	$V_{LCD} = 5\text{ V}$	[4]	-	1.5	10	k Ω
Output pins S0 to S59							
V_S	voltage on pin S	$C_{sgm} = 35\text{ nF}$	[5]	-100	-	+100	mV
R_S	resistance on pin S	$V_{LCD} = 5\text{ V}$	[4]	-	6.0	13.5	k Ω

[1] LCD outputs are open-circuit; inputs at V_{SS} or V_{DD} ; external clock with 50 % duty factor; I²C-bus inactive.

[2] Not tested, design specification only.

[3] C_{bpl} = backplane capacitance.

[4] Measured on sample basis only.

[5] C_{sgm} = segment capacitance.

12. Dynamic characteristics

Table 17. Dynamic characteristics

$V_{DD} = 1.8\text{ V to }5.5\text{ V}$; $V_{SS} = 0\text{ V}$; $V_{LCD} = 2.5\text{ V to }6.5\text{ V}$; $T_{amb} = -40\text{ }^{\circ}\text{C to }+85\text{ }^{\circ}\text{C}$; unless otherwise specified.

Symbol	Parameter	Conditions	Min	Typ	Max	Unit
Clock						
Internal: output pin CLK						
f_{osc}	oscillator frequency	$V_{DD} = 5\text{ V}$	[1] 1440	1970	2640	Hz
External: input pin CLK						
$f_{clk(ext)}$	external clock frequency	$V_{DD} = 5\text{ V}$	800	-	3600	Hz
$t_{clk(H)}$	HIGH-level clock time		130	-	-	μs
$t_{clk(L)}$	LOW-level clock time		130	-	-	μs
Synchronization: input pin SYNC						
$t_{PD(SYNC_N)}$	SYNC propagation delay		-	30	-	ns
t_{SYNC_NL}	SYNC LOW time		1	-	-	μs
Outputs: pins BP0 to BP3 and S0 to S59						
$t_{PD(drv)}$	driver propagation delay	$V_{LCD} = 5\text{ V}$	-	-	30	μs
I²C-bus: timing[2]						
Pin SCL						
f_{SCL}	SCL frequency		-	-	400	kHz
t_{LOW}	LOW period of the SCL clock		1.3	-	-	μs
t_{HIGH}	HIGH period of the SCL clock		0.6	-	-	μs
Pin SDA						
$t_{SU;DAT}$	data set-up time		100	-	-	ns
$t_{HD;DAT}$	data hold time		0	-	-	ns
Pins SCL and SDA						
t_{BUF}	bus free time between a STOP and START condition		1.3	-	-	μs
$t_{SU;STO}$	set-up time for STOP condition		0.6	-	-	μs
$t_{HD;STA}$	hold time (repeated) START condition		0.6	-	-	μs
$t_{SU;STA}$	set-up time for a repeated START condition		0.6	-	-	μs
t_r	rise time of both SDA and SCL signals		-	-	0.3	μs
t_f	fall time of both SDA and SCL signals		-	-	0.3	μs
C_b	capacitive load for each bus line		-	-	400	pF
$t_{w(spike)}$	spike pulse width		-	-	50	ns

[1] Typical output (duty cycle $\delta = 50\%$).

[2] All timing values are valid within the operating supply voltage and ambient temperature range and are referenced to V_{IL} and V_{IH} with an input voltage swing of V_{SS} to V_{DD} .

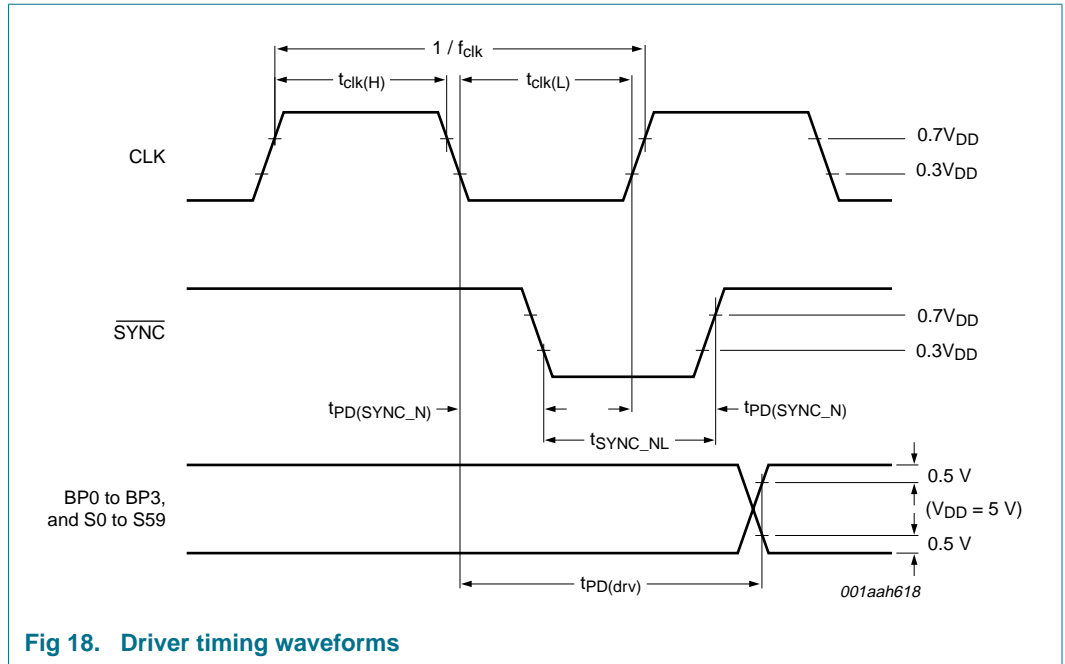

Fig 18. Driver timing waveforms

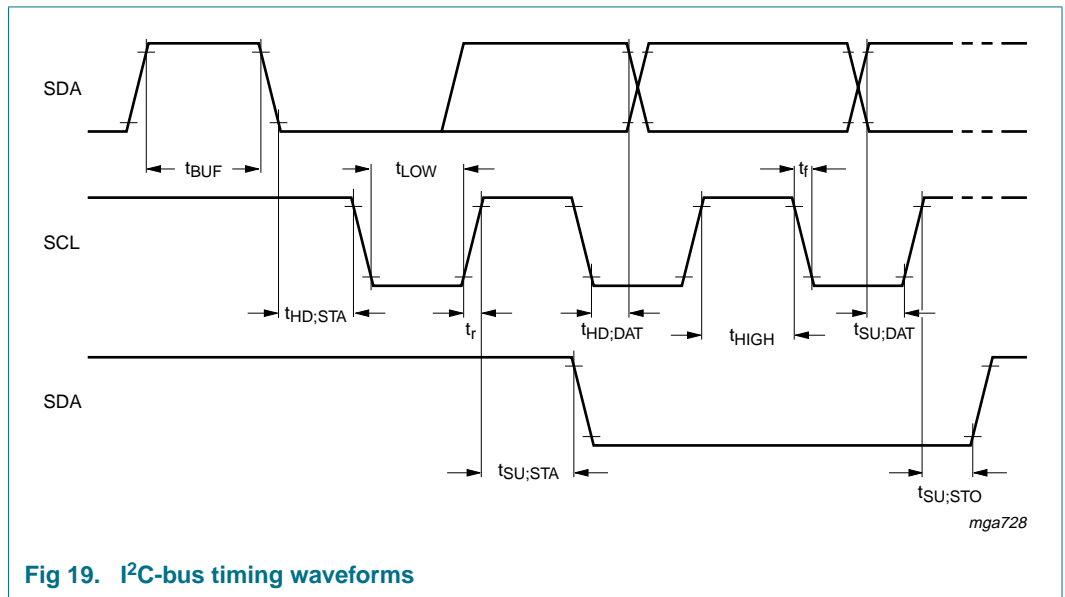

Fig 19. I²C-bus timing waveforms

13. Application information

13.1 Cascaded operation

Large display configurations of up to 16 PCF85134 can be recognized on the same I²C-bus by using the 3-bit hardware subaddress (A0, A1, and A2) and the programmable I²C-bus slave address (SA0).

Table 18. Addressing cascaded PCF85134

Cluster	Bit SA0	Pin A2	Pin A1	Pin A0	Device
1	0	0	0	0	0
		0	0	1	1
		0	1	0	2
		0	1	1	3
		1	0	0	4
		1	0	1	5
		1	1	0	6
		1	1	1	7
2	1	0	0	0	8
		0	0	1	9
		0	1	0	10
		0	1	1	11
		1	0	0	12
		1	0	1	13
		1	1	0	14
		1	1	1	15

When cascaded PCF85134 are synchronized, they can share the backplane signals from one of the devices in the cascade. Such an arrangement is cost-effective in large LCD applications since the backplane outputs of only one device need to be through-plated to the backplane electrodes of the display. The other PCF85134 of the cascade contribute additional segment outputs, but their backplane outputs are left open-circuit (see [Figure 20](#)).

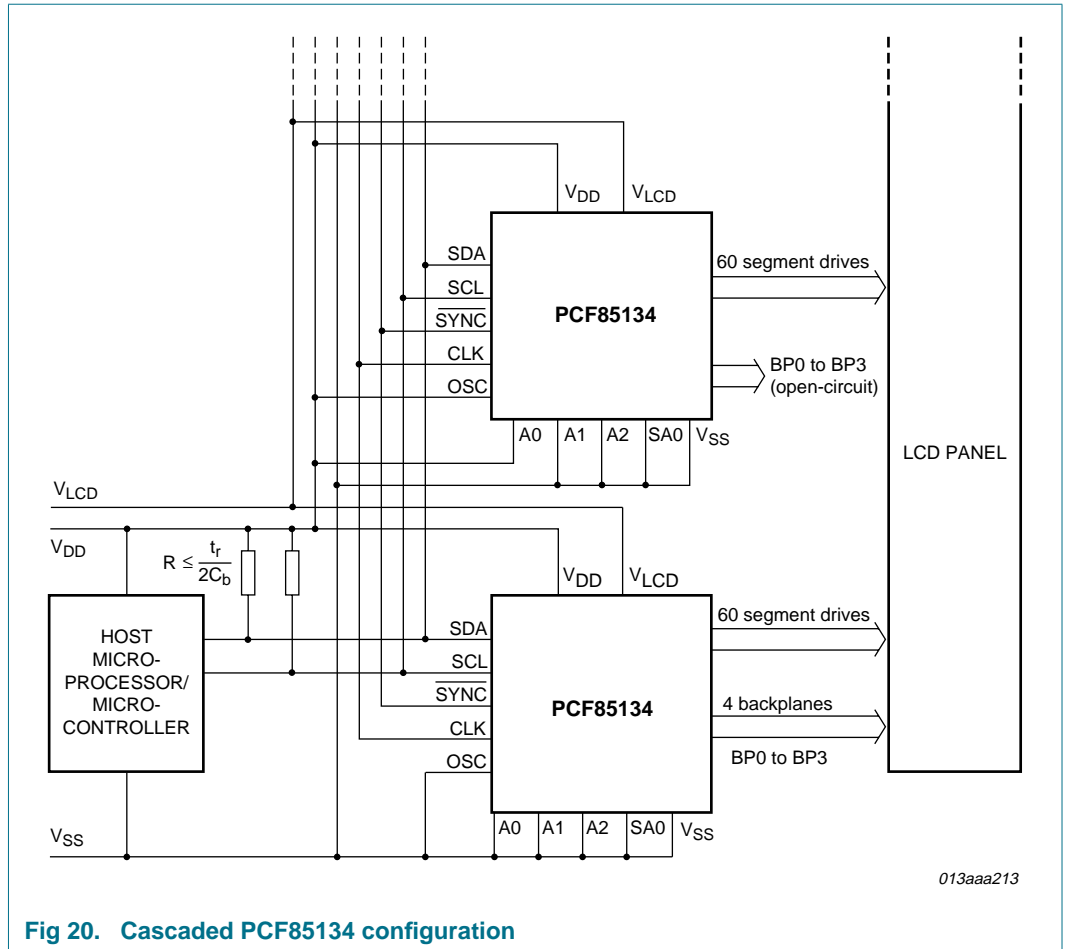

Fig 20. Cascaded PCF85134 configuration

The $\overline{\text{SYNC}}$ line is provided to maintain the correct synchronization between all cascaded PCF85134. Synchronization is guaranteed after a power-on reset. The only time that $\overline{\text{SYNC}}$ is likely to be needed is if synchronization is accidentally lost (e.g. by noise in adverse electrical environments or by defining a multiplex drive mode when PCF85134 with different SA0 levels are cascaded).

$\overline{\text{SYNC}}$ is organized as an input/output pin. The output selection is realized as an open-drain driver with an internal pull-up resistor. A PCF85134 asserts the $\overline{\text{SYNC}}$ line at the onset of its last active backplane signal and monitors the $\overline{\text{SYNC}}$ line at all other times. If synchronization in the cascade is lost, it is restored by the first PCF85134 to assert $\overline{\text{SYNC}}$. The timing relationship between the backplane waveforms and the $\overline{\text{SYNC}}$ signal for the various drive modes of the PCF85134 are shown in [Figure 21](#).

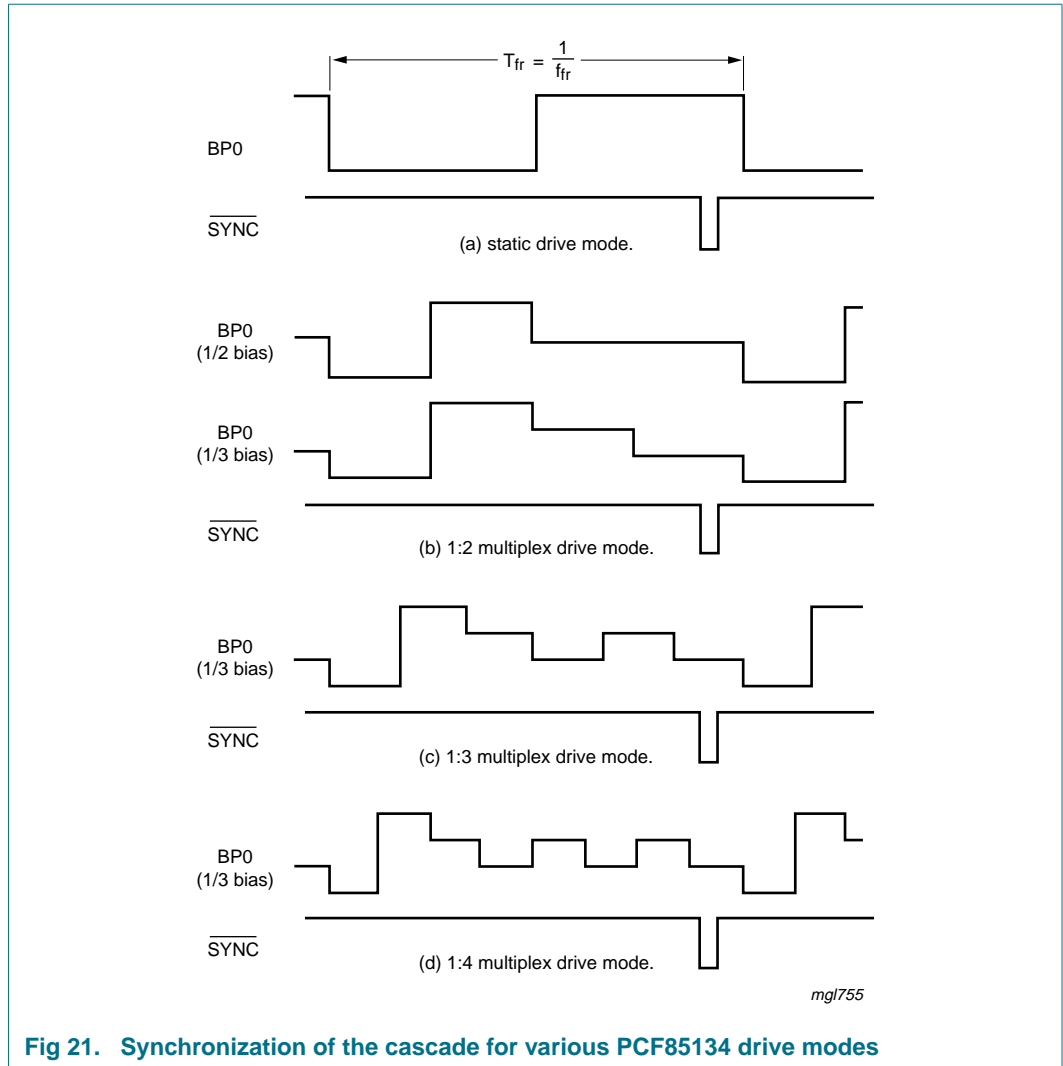

Fig 21. Synchronization of the cascade for various PCF85134 drive modes

The contact resistance between the $\overline{\text{SYNC}}$ pins of cascaded devices must be controlled. If the resistance is too high, the device will not be able to synchronize properly.

[Table 19](#) shows the maximum contact resistance values.

Table 19. $\overline{\text{SYNC}}$ contact resistance

Number of devices	Maximum contact resistance
2	6000 Ω
3 to 5	2200 Ω
6 to 10	1200 Ω
11 to 16	700 Ω

14. Package outline

LQFP80: plastic low profile quad flat package; 80 leads; body 12 x 12 x 1.4 mm

SOT315-1

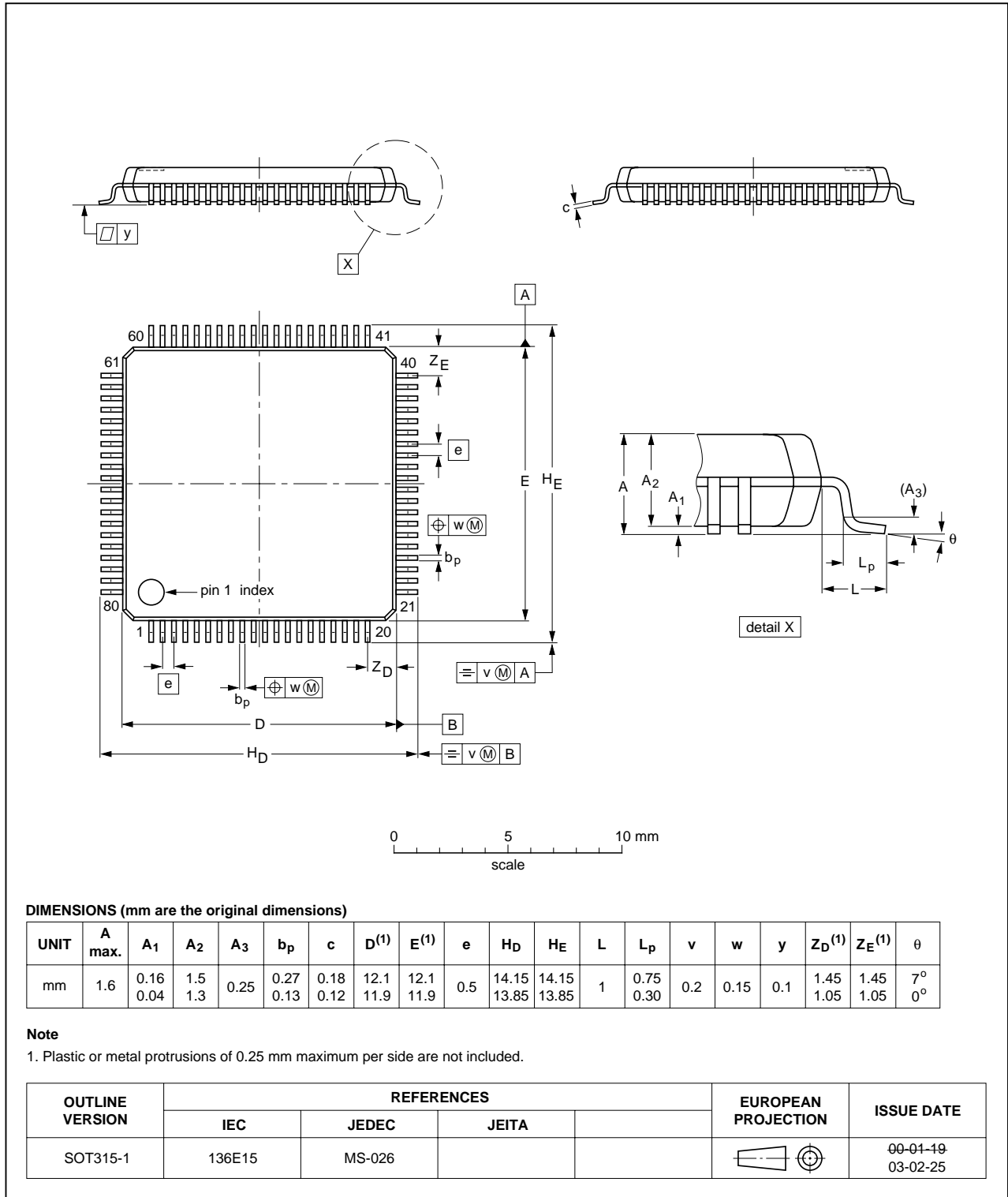

Fig 22. Package outline SOT315-1 (LQFP80)

15. Handling information

All input and output pins are protected against ElectroStatic Discharge (ESD) under normal handling. When handling Metal-Oxide Semiconductor (MOS) devices ensure that all normal precautions are taken as described in *JESD625-A*, *IEC 61340-5* or equivalent standards.

16. Soldering of SMD packages

This text provides a very brief insight into a complex technology. A more in-depth account of soldering ICs can be found in Application Note *AN10365 "Surface mount reflow soldering description"*.

16.1 Introduction to soldering

Soldering is one of the most common methods through which packages are attached to Printed Circuit Boards (PCBs), to form electrical circuits. The soldered joint provides both the mechanical and the electrical connection. There is no single soldering method that is ideal for all IC packages. Wave soldering is often preferred when through-hole and Surface Mount Devices (SMDs) are mixed on one printed wiring board; however, it is not suitable for fine pitch SMDs. Reflow soldering is ideal for the small pitches and high densities that come with increased miniaturization.

16.2 Wave and reflow soldering

Wave soldering is a joining technology in which the joints are made by solder coming from a standing wave of liquid solder. The wave soldering process is suitable for the following:

- Through-hole components
- Leaded or leadless SMDs, which are glued to the surface of the printed circuit board

Not all SMDs can be wave soldered. Packages with solder balls, and some leadless packages which have solder lands underneath the body, cannot be wave soldered. Also, leaded SMDs with leads having a pitch smaller than ~0.6 mm cannot be wave soldered, due to an increased probability of bridging.

The reflow soldering process involves applying solder paste to a board, followed by component placement and exposure to a temperature profile. Leaded packages, packages with solder balls, and leadless packages are all reflow solderable.

Key characteristics in both wave and reflow soldering are:

- Board specifications, including the board finish, solder masks and vias
- Package footprints, including solder thieves and orientation
- The moisture sensitivity level of the packages
- Package placement
- Inspection and repair
- Lead-free soldering versus SnPb soldering

16.3 Wave soldering

Key characteristics in wave soldering are:

- Process issues, such as application of adhesive and flux, clinching of leads, board transport, the solder wave parameters, and the time during which components are exposed to the wave
- Solder bath specifications, including temperature and impurities

16.4 Reflow soldering

Key characteristics in reflow soldering are:

- Lead-free versus SnPb soldering; note that a lead-free reflow process usually leads to higher minimum peak temperatures (see [Figure 23](#)) than a SnPb process, thus reducing the process window
- Solder paste printing issues including smearing, release, and adjusting the process window for a mix of large and small components on one board
- Reflow temperature profile; this profile includes preheat, reflow (in which the board is heated to the peak temperature) and cooling down. It is imperative that the peak temperature is high enough for the solder to make reliable solder joints (a solder paste characteristic). In addition, the peak temperature must be low enough that the packages and/or boards are not damaged. The peak temperature of the package depends on package thickness and volume and is classified in accordance with [Table 20](#) and [21](#)

Table 20. SnPb eutectic process (from J-STD-020C)

Package thickness (mm)	Package reflow temperature (°C)	
	Volume (mm ³)	
	< 350	≥ 350
< 2.5	235	220
≥ 2.5	220	220

Table 21. Lead-free process (from J-STD-020C)

Package thickness (mm)	Package reflow temperature (°C)		
	Volume (mm ³)		
	< 350	350 to 2000	> 2000
< 1.6	260	260	260
1.6 to 2.5	260	250	245
> 2.5	250	245	245

Moisture sensitivity precautions, as indicated on the packing, must be respected at all times.

Studies have shown that small packages reach higher temperatures during reflow soldering, see [Figure 23](#).

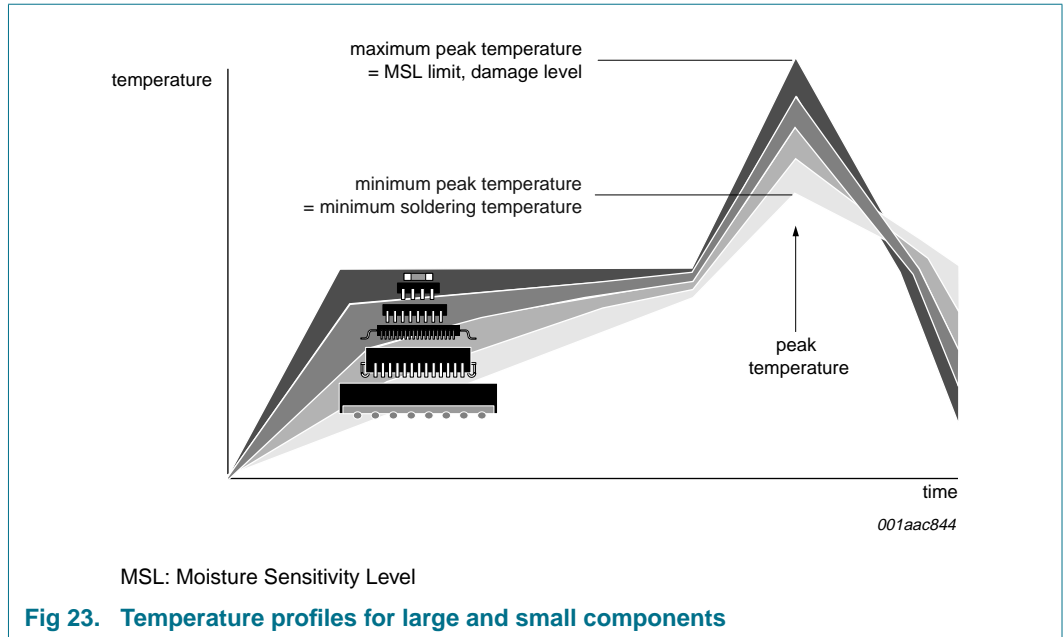

For further information on temperature profiles, refer to Application Note AN10365 “Surface mount reflow soldering description”.

17. Abbreviations

Table 22. Abbreviations

Acronym	Description
CMOS	Complementary Metal-Oxide Semiconductor
ESD	ElectroStatic Discharge
HBM	Human Body Model
IC	Integrated Circuit
LCD	Liquid Crystal Display
MM	Machine Model
RAM	Random Access Memory

18. References

- [1] **AN10365** — Surface mount reflow soldering description
- [2] **IEC 60134** — Rating systems for electronic tubes and valves and analogous semiconductor devices
- [3] **IEC 61340-5** — Protection of electronic devices from electrostatic phenomena
- [4] **IPC/JEDEC J-STD-020D** — Moisture/Reflow Sensitivity Classification for Nonhermetic Solid State Surface Mount Devices
- [5] **JESD22-A114** — Electrostatic Discharge (ESD) Sensitivity Testing Human Body Model (HBM)
- [6] **JESD22-A115** — Electrostatic Discharge (ESD) Sensitivity Testing Machine Model (MM)
- [7] **JESD78** — IC Latch-Up Test
- [8] **JESD625-A** — Requirements for Handling Electrostatic-Discharge-Sensitive (ESDS) Devices
- [9] **NX3-00092** — NXP store and transport requirements
- [10] **SNV-FA-01-02** — Marking Formats Integrated Circuits
- [11] **UM10204** — I²C-bus specification and user manual

19. Revision history

Table 23. Revision history

Document ID	Release date	Data sheet status	Change notice	Supersedes
PCF85134_1	20091217	Product data sheet	-	-

20. Legal information

20.1 Data sheet status

Document status ^{[1][2]}	Product status ^[3]	Definition
Objective [short] data sheet	Development	This document contains data from the objective specification for product development.
Preliminary [short] data sheet	Qualification	This document contains data from the preliminary specification.
Product [short] data sheet	Production	This document contains the product specification.

[1] Please consult the most recently issued document before initiating or completing a design.

[2] The term 'short data sheet' is explained in section "Definitions".

[3] The product status of device(s) described in this document may have changed since this document was published and may differ in case of multiple devices. The latest product status information is available on the Internet at URL <http://www.nxp.com>.

20.2 Definitions

Draft — The document is a draft version only. The content is still under internal review and subject to formal approval, which may result in modifications or additions. NXP Semiconductors does not give any representations or warranties as to the accuracy or completeness of information included herein and shall have no liability for the consequences of use of such information.

Short data sheet — A short data sheet is an extract from a full data sheet with the same product type number(s) and title. A short data sheet is intended for quick reference only and should not be relied upon to contain detailed and full information. For detailed and full information see the relevant full data sheet, which is available on request via the local NXP Semiconductors sales office. In case of any inconsistency or conflict with the short data sheet, the full data sheet shall prevail.

20.3 Disclaimers

General — Information in this document is believed to be accurate and reliable. However, NXP Semiconductors does not give any representations or warranties, expressed or implied, as to the accuracy or completeness of such information and shall have no liability for the consequences of use of such information.

Right to make changes — NXP Semiconductors reserves the right to make changes to information published in this document, including without limitation specifications and product descriptions, at any time and without notice. This document supersedes and replaces all information supplied prior to the publication hereof.

Suitability for use — NXP Semiconductors products are not designed, authorized or warranted to be suitable for use in medical, military, aircraft, space or life support equipment, nor in applications where failure or malfunction of an NXP Semiconductors product can reasonably be expected to result in personal injury, death or severe property or environmental

damage. NXP Semiconductors accepts no liability for inclusion and/or use of NXP Semiconductors products in such equipment or applications and therefore such inclusion and/or use is at the customer's own risk.

Applications — Applications that are described herein for any of these products are for illustrative purposes only. NXP Semiconductors makes no representation or warranty that such applications will be suitable for the specified use without further testing or modification.

Limiting values — Stress above one or more limiting values (as defined in the Absolute Maximum Ratings System of IEC 60134) may cause permanent damage to the device. Limiting values are stress ratings only and operation of the device at these or any other conditions above those given in the Characteristics sections of this document is not implied. Exposure to limiting values for extended periods may affect device reliability.

Terms and conditions of sale — NXP Semiconductors products are sold subject to the general terms and conditions of commercial sale, as published at <http://www.nxp.com/profile/terms>, including those pertaining to warranty, intellectual property rights infringement and limitation of liability, unless explicitly otherwise agreed to in writing by NXP Semiconductors. In case of any inconsistency or conflict between information in this document and such terms and conditions, the latter will prevail.

No offer to sell or license — Nothing in this document may be interpreted or construed as an offer to sell products that is open for acceptance or the grant, conveyance or implication of any license under any copyrights, patents or other industrial or intellectual property rights.

Export control — This document as well as the item(s) described herein may be subject to export control regulations. Export might require a prior authorization from national authorities.

20.4 Trademarks

Notice: All referenced brands, product names, service names and trademarks are the property of their respective owners.

I²C-bus — logo is a trademark of NXP B.V.

21. Contact information

For more information, please visit: <http://www.nxp.com>

For sales office addresses, please send an email to: salesaddresses@nxp.com

22. Contents

1	General description	1	13.1	Cascaded operation	31
2	Features	1	14	Package outline	34
3	Ordering information	2	15	Handling information	35
4	Marking	2	16	Soldering of SMD packages	35
5	Block diagram	3	16.1	Introduction to soldering	35
6	Pinning information	4	16.2	Wave and reflow soldering	35
6.1	Pinning	4	16.3	Wave soldering	36
6.2	Pin description	5	16.4	Reflow soldering	36
7	Functional description	6	17	Abbreviations	37
7.1	Power-On Reset (POR)	6	18	References	38
7.2	LCD bias generator	7	19	Revision history	38
7.3	LCD voltage selector	7	20	Legal information	39
7.4	LCD drive mode waveforms	9	20.1	Data sheet status	39
7.4.1	Static drive mode	9	20.2	Definitions	39
7.4.2	1:2 Multiplex drive mode	10	20.3	Disclaimers	39
7.4.3	1:3 Multiplex drive mode	12	20.4	Trademarks	39
7.4.4	1:4 Multiplex drive mode	13	21	Contact information	39
7.5	Oscillator	14	22	Contents	40
7.5.1	Internal clock	14			
7.5.2	External clock	14			
7.6	Timing and frame frequency	14			
7.7	Display register	14			
7.8	Segment outputs	14			
7.9	Backplane outputs	15			
7.10	Display RAM	15			
7.11	Data pointer	17			
7.12	Subaddress counter	17			
7.13	Output bank selector	18			
7.14	Input bank selector	18			
7.15	Blinker	18			
8	Basic architecture	20			
8.1	Characteristics of the I ² C-bus	20			
8.1.1	Bit transfer	20			
8.1.1.1	START and STOP conditions	20			
8.1.2	System configuration	20			
8.1.3	Acknowledge	21			
8.1.4	I ² C-bus controller	22			
8.1.5	Input filters	22			
8.2	I ² C-bus protocol	22			
8.3	Command decoder	24			
8.4	Display controller	25			
9	Internal circuitry	26			
10	Limiting values	27			
11	Static characteristics	28			
12	Dynamic characteristics	29			
13	Application information	31			

Please be aware that important notices concerning this document and the product(s) described herein, have been included in section 'Legal information'.

founded by

PHILIPS

© NXP B.V. 2009.

All rights reserved.

For more information, please visit: <http://www.nxp.com>

For sales office addresses, please send an email to: salesaddresses@nxp.com

Date of release: 17 December 2009

Document identifier: PCF85134_1