

## IWTTU Series

### Industrial Wireless Temperature Transducer - 1/4"NPT



- **K or J Type Thermocouples**
- **PT100 RTD Sensors**
- **6mm stainless steel sheath**
- **Up to 750m line-of-site range (depending on receiver)**
- **Five year battery life at 10 second transmission update rate**
- **Simple DIL switch pairing with the single or five channel receiver**
- **Single or five channel receivers available**
- **User-selectable transmission update rates**
- **User-selectable 1-5V or 4-20mA receiver outputs**
- **Receiver clean contacts provide process alarm functions**

#### DESCRIPTION

The IWTTU Wireless Temperature Transducer is a cost effective replacement to a traditionally wired temperature transducer that offers the advantages of a low-cost installation in inaccessible and expensive installation environments.

It is easily paired to the compatible IWR family of single- or five-channel wireless receivers thus offering a “plug and play” solution to your temperature measurement applications.

The instrument uses either J or K type thermocouples or 3-wire RTD sensors fitted to an acetal housing giving excellent media compatibility for the harshest of applications. Compression fittings are available which allow the head to be orientated in the required direction.

The IWTT sensor should be used with either an IWR-1 or IWR-5 receiver. A line-of-sight range of up to 750m is possible depending on the wireless receiver used (refer to datasheets IWR-1 & IWR-5 for further information).

Each device is temperature compensated, calibrated and supplied with a traceable serial number.

#### TYPICAL APPLICATIONS INCLUDE:-

- **Simple cable replacement installation** – dispense with expensive cable runs
- **Environmental monitoring** – pumping stations, sewage plants, water treatment
- **Facilities management** – boiler rooms, plant hydraulics, plant pneumatics
- **Asset monitoring** – tanks farms, process plants, HVAC and building management
- **Service Contract** – temporary installation for servicing and field trials

#### Transmitter Temperature Ranges

Standard products are factory configured as below:-

J-Type	0 to 1200°C
K-Type	0 to 1200°C
RTD type	-200 to +800°C

#### System Performance

Accuracy (Non-Linearity & Hysteresis)	<±0.1% / FS
Temperature Coefficient	±500ppm/°C

#### Transmitter Output

*Transmission Frequency	2.4 Ghz
Transmit Power	18 dBm
System Channel	User selectable via DIL switch
Antenna	Integral OdBi

\*Compliant with EN 300 328, V1.8.1

#### Instrument Power Source

Battery Type	User replaceable Lithium C cell
Battery Life	Five years at 10 second update rate
Battery Shelf Life	10 years

Cynergy3 Components Ltd.  
 Ferndown Industrial Estate  
 7 Cobham Road  
 Wimborne, Dorset BH21 7PE  
 Telephone +44 (0) 1202 897969  
 Email:sales@cynergy3.com

**ISO9001 CERTIFIED**

IWTTU 2018



Made in the UK

[www.cynergy3.com](http://www.cynergy3.com)

# IWTTU Series

## Industrial Wireless Temperature Transducer - 1/4"NPT

### Material Specifications

Probe sheath	316 Stainless Steel
"O" ring seals	Viton
Wireless Enclosure Material	Acetal
Weight	300g typical including battery
**Installation position	Any

\*\* Consult installation manual to ensure adequate signal path between transmitter and receiver

### Temperatures & Thermal Effects

Media Temperature	-200°C to +1200°C
Op. /Ambient Temperature	-20°C to +50°C
Storage Temperature	-20°C to +80°C
Thermal Span Shift	<±0.05% /°C typical

### Receiver Output Signals (requires either IWR-1 or IWR-5 receiver)

Outputs	1-5V or 4-20mA per channel
Single Channel Receiver	IWR-1 (see data sheet)
Five Channel receiver	IWR-5 (see data sheet)
Alarm Output	5 Amp rated changeover contacts
***Transmission Update Rate	1, 5, 10, 20, 30, 60, 120 & 600 seconds

\*\*\* Consult installation manual for set-up:

- single channel system is DIL switch configurable
- five channel system requires set-up using "IWR Set" user software

### Mechanical Stability

See user manual

### Ordering Codes:-

Temperature Transducer	See table below
Spare battery	IBAT-1
Single Channel Receiver	IWR-1
Five Channel Receiver	IWR-5
Five Channel Configuration Software	IWR-Set (free download*)

\*Download user configuration software from:-

[https://www.cynergy3.com/sites/default/files/ITT\\_Config\\_upload\\_file\\_for\\_WIN7%2B.zip](https://www.cynergy3.com/sites/default/files/ITT_Config_upload_file_for_WIN7%2B.zip)

Part No.	Description	Part No.	Description
IWTTUP100A	PT100 6x100mm	IWTTUJ200A	J type 6x200mm
IWTTUP150A	PT100 6x150mm	IWTTUJ300A	J type 6x300mm
IWTTUP200A	PT100 6x200mm	IWTTUJ400A	J type 6x400mm
IWTTUP250A	PT100 6x250mm	IWTTUK150A	K type 6x150mm
IWTTUP300A	PT100 6x300mm	IWTTUK200A	K type 6x200mm
IWTTUP400A	PT100 6x400mm	IWTTUK300A	K type 6x300mm
		IWTTUK400A	K type 6x400mm

### Mechanical Dimensions

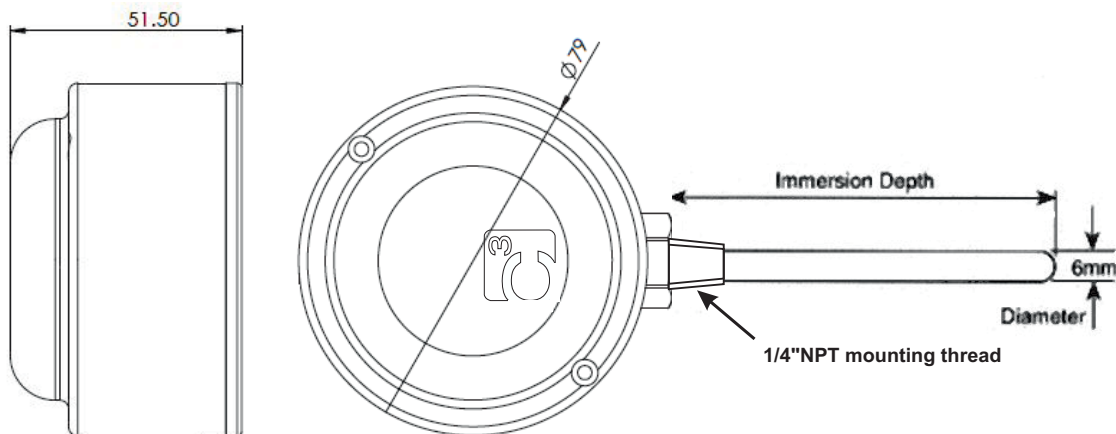

Cynergy3 Components Ltd.  
7 Cobham Road  
Ferndown Industrial Estate  
Wimborne, Dorset BH21 7PE  
Telephone +44 (0) 1202 897969  
Email:sales@cynergy3.com

ISO9001 CERTIFIED



Made in the UK