

ATV cabinets



Commercial status

To be discontinued on: 31 December 2023

To be end-of-service on: 31 December 2031

⚠ To be discontinued

Main

Range of product	Altivar 71 Plus
Product or component type	Variable speed drive
Device short name	ATV71 Plus
Product destination	Synchronous motors Asynchronous motors
Product specific application	Complex, high-power machines
Assembly style	With integrated cooling circuit In floor-standing enclosure with separate air flows
Product composition	An IP65 remote mounting kit for graphic display terminal A switch and fast-acting fuses Terminals/bars for motor connection Integrated drive system ATV71EC63YE1 Control transformer for 230 V A wired ready-assembled Sarel Spacial 6000 enclosure
EMC filter	Integrated
Network number of phases	3 phases
Rated supply voltage	690 V +/- 10 %
Supply voltage limits	621...759 V
Supply frequency	50...60 Hz +/- 5 %
Network frequency	47.5...63 Hz
Motor power kW	630 kW, 3 phases at 690 V
Line current	654 A for 690 V / 630 kW

Complementary

Apparent power	782 kVA for 690 V / 630 kW
Prospective line I _{sc}	100 kA with external fuses
Continuous output current	675 A at 2.5 kHz, 690 V / 630 kW
Maximum transient current	1012 A for 60 s / 630 kW
Speed drive output frequency	0.1...500 Hz
Nominal switching frequency	2.5 kHz
Switching frequency	2...4.9 kHz adjustable 2.5...4.9 kHz with derating factor
Speed range	1...100 for asynchronous motor in open-loop mode, without speed feedback 1...50 for synchronous motor in open-loop mode, without speed feedback

	1...1000 for asynchronous motor in closed-loop mode with encoder feedback
Speed accuracy	+/- 0.01 % of nominal speed in closed-loop mode with encoder feedback 0.2 Tn to Tn +/- 10 % of nominal slip without speed feedback 0.2 Tn to Tn
Torque accuracy	+/- 5 % in closed-loop mode with encoder feedback +/- 15 % in open-loop mode, without speed feedback
Transient overtorque	170 % of nominal motor torque for 60 s 220 % of nominal motor torque for 2 s
Braking torque	30 % without braking resistor <= 150 % with braking or hoist resistor
Asynchronous motor control profile	Flux vector control without sensor, standard Voltage/frequency ratio - Energy Saving, quadratic U/f Voltage/frequency ratio, 5 points Flux vector control with sensor, standard Flux vector control without sensor, ENA (energy Adaptation) system Voltage/frequency ratio, 2 points Flux vector control without sensor, 2 points
Synchronous motor control profile	Vector control with sensor, standard Vector control without sensor, standard
Regulation loop	Adjustable PI regulator
Motor slip compensation	Automatic whatever the load Adjustable Not available in voltage/frequency ratio (2 or 5 points) Suppressable
Overvoltage category	Class 3 conforming to EN 50178
Local signalling	LCD display unit for operation function, status and configuration - mounted in the front door
Output voltage	<= supply voltage
Isolation	Electrical between power and control
Type of cable for external connection	IEC cable at 40 °C, copper 70 °C / PVC UL 508 cable at 40 °C, copper 75 °C / PVC
Electrical connection	Bar M12 - 10 x 240 mm ² (L1/R, L2/S, L3/T) bottom entry at 6-pulse operation Bar M12 - 4 x 240 mm ² (L1/R, L2/S, L3/T) bottom entry at 12-pulse operation Bar M12 - 16 x 240 mm ² (U/T1, V/T2, W/T3) bottom entry Terminal - 2.5 mm ² / AWG 14 (R1A, R1B, R1C, R2A, R2B) bottom entry Screw clamp terminals - 1.5 mm ² (AI1-/AI1+, AI2, AO1, LI1...LI6, PWR) bottom entry
Motor recommended cable cross section	3 (3 x 150) mm ²
Short-circuit protection	1000 A fuse protection type gI - power supply upstream - at 6-pulse operation 500 A fuse protection type gI - power supply upstream - at 12-pulse operation
Supply	External supply: 24 V DC (19...30 V), <1 A Internal supply for reference potentiometer: 10 V DC (10...11 V), <10 mA Internal supply: 24 V DC (21...27 V), <100 mA
Analogue input number	2
Analogue input type	AI2 software-configurable voltage: 0...10 V DC, 24 V max, impedance: 30000 Ohm, sampling time: 1.5...2.5 ms, resolution: 11 bits AI1-/AI1+ bipolar differential voltage: +/- 10 V DC, 24 V max, sampling time: 1.5...2.5 ms, resolution: 11 bits + sign AI2 software-configurable current: 0...20 mA/4...20 mA, impedance: 250 Ohm, sampling time: 1.5...2.5 ms, resolution: 11 bits
Analogue output number	1
Analogue output type	Software-configurable voltage: (AO1) 0...10 V DC - 470 Ohm - sampling time: 1.5...2.5 ms - resolution: 10 bits Software-configurable current: (AO1) 0...20 mA/4...20 mA - 500 Ohm - sampling time: 1.5...2.5 ms - resolution: 10 bits
Discrete output number	2
Discrete output type	Configurable relay logic: (R1A, R1B, R1C)NO/NC - 6.5...7.5 ms - 100000 cycles Configurable relay logic: (R2A, R2B)NO - 6.5...7.5 ms - 100000 cycles
Minimum switching current	3 mA at 24 V DC (configurable relay logic)
Maximum switching current	5 A at 250 V AC on resistive load - cos phi = 1 (R1, R2) 5 A at 30 V DC on resistive load - L/R = 0 ms (R1, R2) 2 A at 250 V AC on inductive load - cos phi = 0.4 (R1, R2) 2 A at 30 V DC on inductive load - L/R = 7 ms
Discrete input number	7
Discrete input type	Programmable (LI1...LI5) at 24 V DC <= 30 V level 1 PLC 3.5 kOhm (duration=1.5...2.5 ms) Switch-configurable (LI6) at 24 V DC <= 30 V level 1 PLC 1.5 kOhm (duration=1.5...2.5 ms)

	Safety input (PWR) at 24 V DC \leq 30 V 1.5 kOhm
Discrete input logic	Positive logic (source) (LI1...LI5), 0...5 V (state 0), 11...30 V (state 1) Negative logic (sink) (LI1...LI5), 16...30 V (state 0), 0...10 V (state 1) Positive logic (source) (PWR), 0...2 V (state 0), 17...30 V (state 1)
Acceleration and deceleration ramps	S, U or customized Linear adjustable separately from 0.01 to 9000 s
Braking to standstill	By DC injection
Protection type	Overheating protection: drive Thermal protection: drive Short-circuit between motor phases: drive Input phase breaks: drive Overcurrent between output phases and earth: drive Overvoltages on the DC bus: drive Break on the control circuit: drive Against exceeding limit speed: drive Line supply undervoltage: drive Line supply overvoltage: drive Against input phase loss: drive Thermal protection: motor Motor phase break: motor Power removal: motor
Dielectric strength	3535 V DC between earth and power terminals 5092 V DC between control and power terminals
Insulation resistance	> 1 mOhm 500 V DC for 1 minute to earth
Frequency resolution	Display unit: 0.1 Hz Analog input: 0.024/50 Hz
Communication port protocol	CANopen Modbus
Connector type	1 RJ45 (on front face) for Modbus 1 RJ45 (on terminal) for Modbus Male SUB-D 9 on RJ45 for CANopen
Physical interface	2-wire RS 485 for Modbus
Transmission frame	RTU for Modbus
Transmission rate	9600 bps, 19200 bps for Modbus on front face 4800 bps, 9600 bps, 19200 bps, 38.4 Kbps for Modbus on terminal 20 kbps, 50 kbps, 125 kbps, 250 kbps, 500 kbps, 1 Mbps for CANopen
Data format	8 bits, 1 stop, even parity for Modbus on front face 8 bits, odd even or no configurable parity for Modbus on terminal
Type of polarization	No impedance for Modbus
Number of addresses	1...247 for Modbus 1...127 for CANopen
Method of access	Slave CANopen
Option card	Communication card for Modbus TCP/IP Communication card for Fipio Communication card for Modbus/Uni-Telway Communication card for Modbus Plus Communication card for EtherNet/IP Communication card for DeviceNet Communication card for Profibus DP Communication card for Profibus DP V1 Communication card for Interbus-S Communication card for CC-Link Basic I/O extension card Extended I/O extension card Controller inside programmable card Encoder interface cards
Options for enclosure configuration	Safe standstill for power circuit PTC relay for power circuit Pt100 relay for power circuit Insulation monitoring for power circuit Design for IT networks for power circuit External 230 V supply terminals for power circuit Buffer voltage 24 V DC power supply for power circuit External 24 V DC supply terminals for power circuit Enclosure lighting for power circuit Key switch (local/remote) for power circuit Motor heating for power circuit External motor fan for power circuit

Voltmeter for power circuit
 Door handle for main switch for power circuit
 Circuit breaker for power circuit
 Line contactor for power circuit
 12-pulse supply for power circuit
 Line reactor for power circuit
 Ammeter for power circuit
 Enclosure heating for power circuit
 Motor choke for power circuit
 Cable entry via the top for power circuit
 Enclosure plinth for power circuit
 Door handle for circuit breaker for power circuit
 Control terminals for control circuit
 Adaptor for 115 V logic inputs for control circuit
 Relay output C/O for control circuit
 Isolated amplifier for control circuit

Operating position	Vertical +/- 10 degree
Colour of enclosure	Light grey (RAL 7035)
Colour of base of enclosure	Dark grey (RAL 7022)
Height	2009 mm
Width	1800 mm
Depth	642 mm
Net weight	950 kg

Environment

Electromagnetic compatibility	Electrostatic discharge immunity test level 3 conforming to IEC 61000-4-2 Radiated radio-frequency electromagnetic field immunity test level 3 conforming to IEC 61000-4-3 Electrical fast transient/burst immunity test level 4 conforming to IEC 61000-4-4 1.2/50 μ s - 8/20 μ s surge immunity test level 3 conforming to IEC 61000-4-5 Conducted radio-frequency immunity test level 3 conforming to IEC 61000-4-6 Voltage dips and interruptions immunity test conforming to IEC 61000-4-11
Pollution degree	2 conforming to EN/IEC 61800-5-1
IP degree of protection	IP23
Vibration resistance	1.5 mm peak to peak (f= 3...10 Hz) conforming to EN/IEC 60068-2-6 0.6 gn (f= 10...200 Hz) conforming to EN/IEC 60068-2-6 3M3 conforming to EN/IEC 60721-3-3
Shock resistance	4 gn for 11 ms conforming to EN/IEC 60068-2-27 3M2 conforming to EN/IEC 60721-3-3
Noise level	77 dB conforming to 86/188/EEC
Environmental characteristic	Without condensation: 3C2 conforming to IEC 60721-3-3 Without condensation: 3S2 conforming to IEC 60721-3-3 Without condensation: 3K3 conforming to IEC 60721-3-3
Relative humidity	0...95 %
Ambient air temperature for operation	0...40 °C (without derating) 40...50 °C (with current derating of 1.2 % per °C)
Ambient air temperature for storage	-25...70 °C
Volume of cooling air	5500 m ³ /h
Operating altitude	<= 1000 m without derating 1000...3000 m with current derating 1 % per 100 m
Standards	EN/IEC 61800-3 EN 61800-3 environments 2 category C3 EN/IEC 61800-5-1 EN 61800-3 environments 1 category C3 EN 55011 class A group 2
Product certifications	ATEX GOST
Marking	CE

Packing Units

Package 1 Weight	900.000 kg
Package 1 Height	20.000 dm
Package 1 width	6.600 dm

Package 1 Length	18.300 dm
------------------	-----------

Contractual warranty

Warranty	18 months
----------	-----------

IP 23 Floor-Standing Enclosure with Separate Air Flows

Dimensions

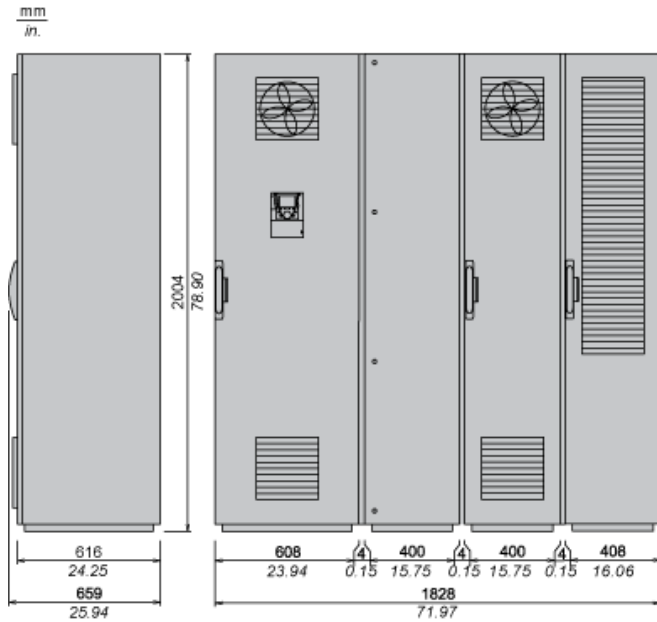

NOTE: For each floor-standing enclosure added, allow a 4 mm/0.15 in. space for the seal.

Floor-Standing Enclosure with Separate Air Flows

Standard 6-pulse Design

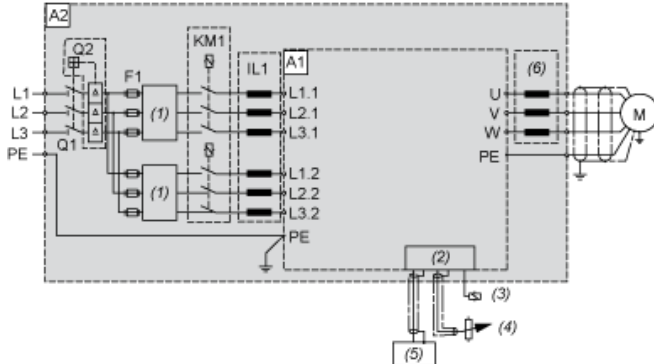

- A1 Drive
- A2 Enclosure
- F1 Fuses
- IL1 Optional line choke
- KM1 Optional line contactor
- M Motor
- Q1 Switch
- Q2 Optional circuit breaker
- (1) Filter
- (2) Control
- (3) Relay control
- (4) Reference potentiometer
- (5) PLC
- (6) Optional motor choke

Optional 12-pulse Design

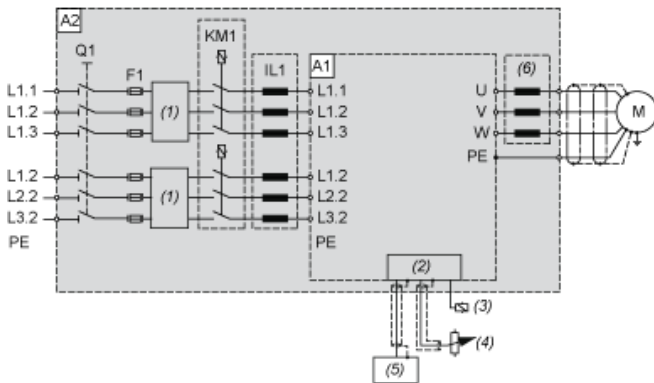

- A1 Drive
- A2 Enclosure
- F1 Fuses
- IL1 Optional line choke
- KM1 Optional line contactor
- M Motor
- Q1 Switch
- (1) Filter
- (2) Control
- (3) Relay control
- (4) Reference potentiometer
- (5) PLC
- (6) Optional motor choke

IP 23 Floor-Standing Enclosure with Separate Air Flows

Derating Curves

The derating curves for the drive nominal current (I_n) are dependent on the temperature and switching frequency. For intermediate temperatures, interpolate between 2 curves.

NOTE: The drive will reduce the switching frequency automatically in the event of excessive temperature rise.

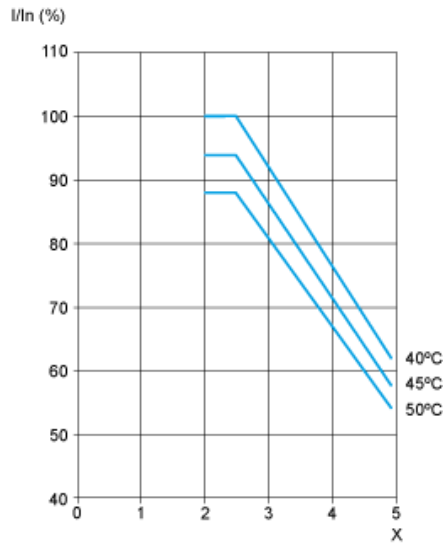

X Switching frequency (kHz)

NOTE: The temperatures shown correspond to the temperature of the air entering the enclosure.