

MS-216-7

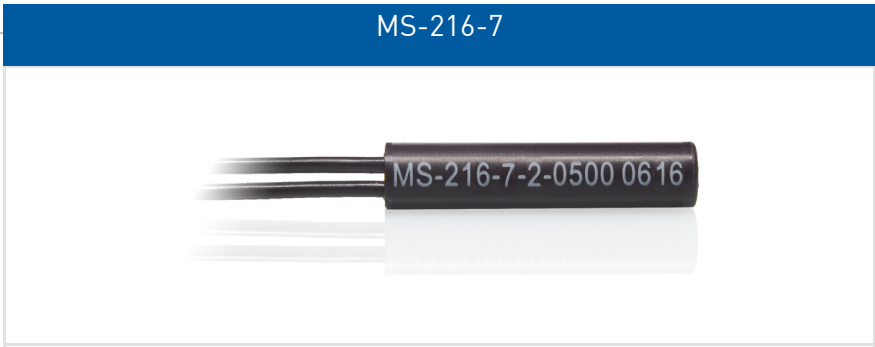

MS-216-7

Normally Closed Reed Sensor

Electrical Characteristics		@ 25 °C
Contact form		B
Contact rating max.	W / VA	5
Switching voltage max.	VDC	175
	VAC	120
Switching current max.	A	0.25
Carry current max.	A	1.5
Breakdown voltage min.	VDC	200
Total resistance max. (initial)	mΩ	200
Insulation resistance min.	Ω	10 ⁹

Features
> Compact size
> Mechanically protected
> Non pole oriented actuation
> Customized types available

Magnetical Characteristics (of unmodified Reed Switch)		@ 25 °C
Pull in range available	AT	15 - 30
Drop out min.	AT	5
Test coil	TC	200
Test equipment tolerance	± AT	2

Approvals





Operating Characteristics (of unmodified Reed Switch)		@ 25 °C
Switching frequency max.	Hz	100
Resonant frequency typ.	Hz	1100
Operate time max. (incl. bounce)	ms	0.7
Release time max.	ms	1

Environmental Characteristics		
Operating temperature	°C	-20 to +85
Vibration (50-2000 Hz)	g	30
Shock (1/2 sin 11 ms)	g	50

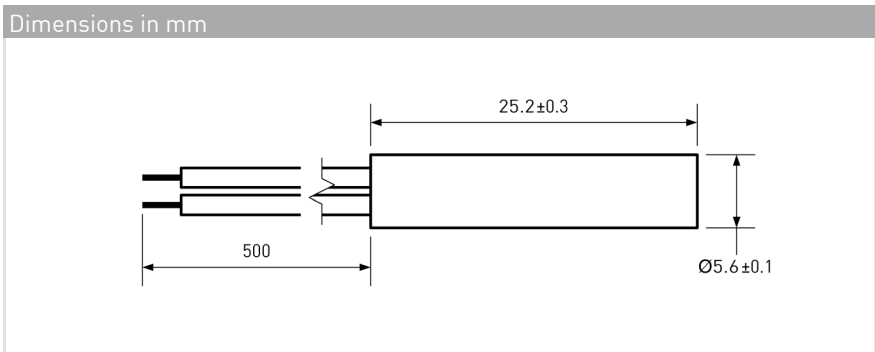

Ordering Information	
Packing Unit	50 pcs
Weight per piece	3.8 g
Weight per package	195 g
Standard AT Ranges	
	2 = 15 to 20 AT
	3 = 20 to 25 AT
	4 = 25 to 30 AT
Ordering Example	
MS-216-7-2-0500 describes MS-216-7 with 15 to 20 AT.	

© PIC GmbH

MS-216-7

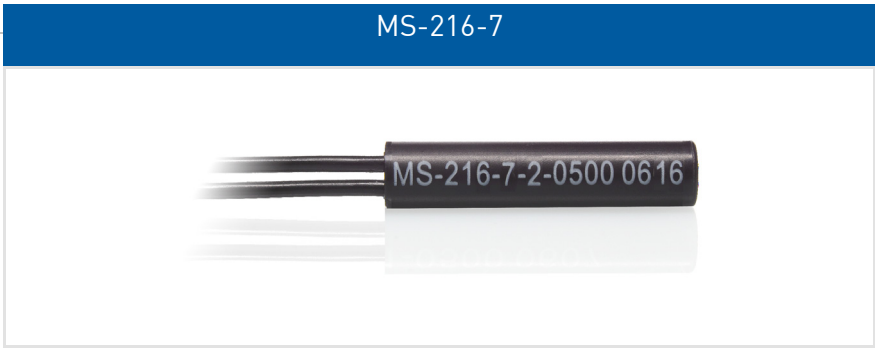

MS-216-7

Normally Closed Reed Sensor

Material Information		
	Material	Colour
Housing	ABS	black
Cable	UL 1007/1569, AWG 24, 4 mm stripped and tinned	black
Potting compound	Epoxy	black

Test Procedure of final Reed Sensor

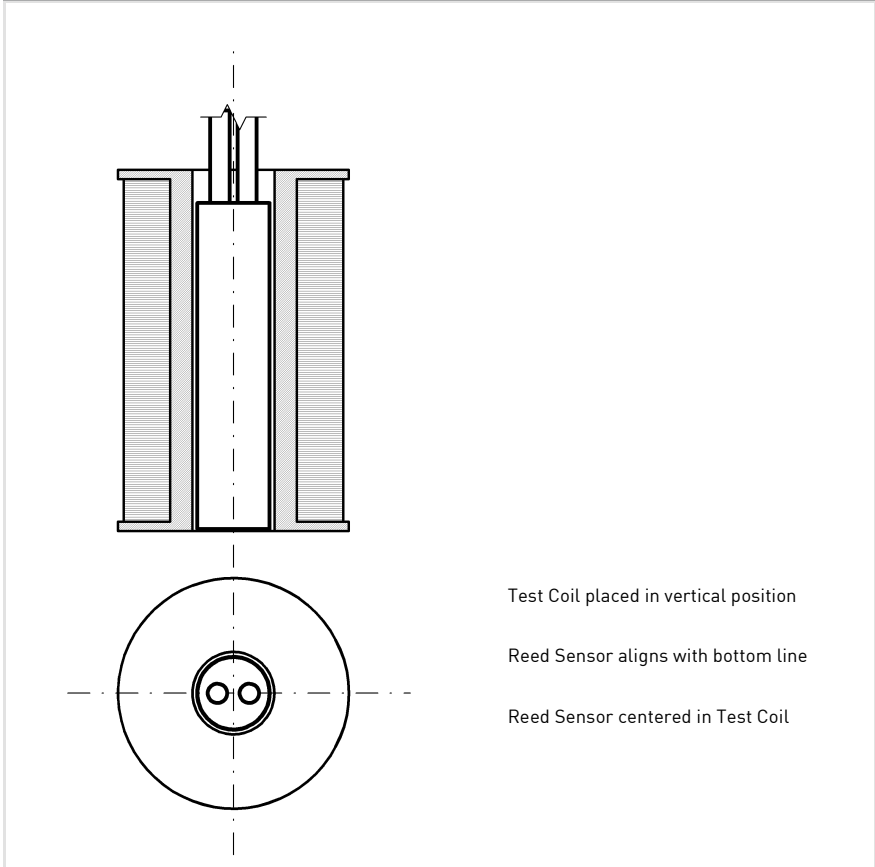

Test Parameters

Test coil	TC- 093
Test programs	
AT range	Test program
2 =	MS-216-7-2
3 =	MS-216-7-3
4 =	MS-216-7-4

Remarks

When mounted onto ferromagnetic parts switching distance of MS-216-7 may reduce.
Electromagnetical influences and magnetic fields may change the switching behaviour of the sensor.

Product image serves as example only.