

**RTM/STM 1686/1696/1736/1687/1697/1737**

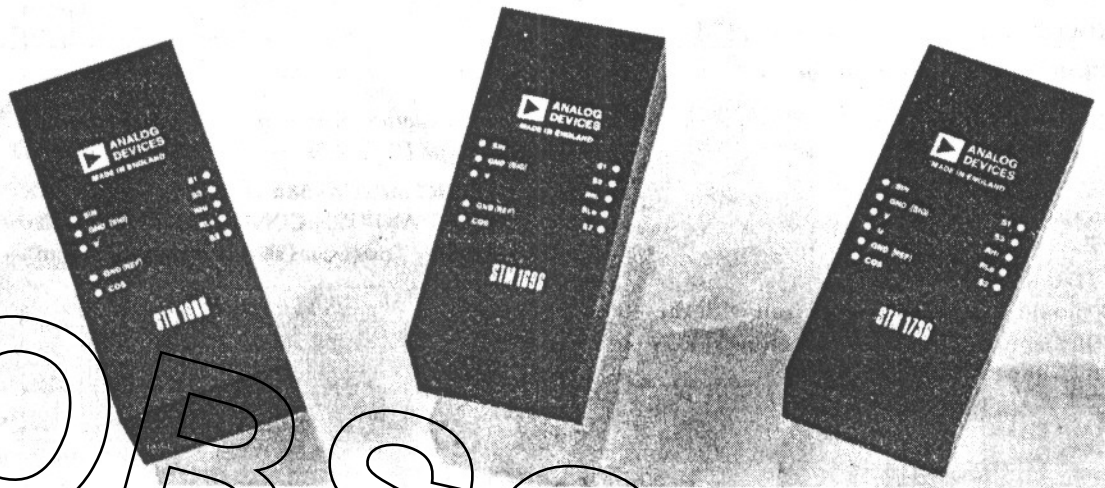

**RTM/STM 1686**

**SPECIFICATIONS** (typical @ +25°C unless otherwise noted)

ACCURACY <sup>1</sup> (after balancing)	±2.4 arc minutes
OPERATING FREQUENCY	400Hz
LOAD CAPABILITY	5VA
OPERATING TEMPERATURE	-55°C to +105°C
STORAGE TEMPERATURE	-55°C to +125°C
VOLTAGE ISOLATION	500V dc
WEIGHT	21 ounces (580G)

- NOTES**
- <sup>1</sup> Accuracy applies over the full operating temperature range of the option and for:
    - (a) ±10% reference frequency and amplitude variation.
    - (b) 10% harmonic distortion on the reference.
    - (c) Any balanced load from no load to full load.

Specifications subject to change without notice.

**APPLICATION OF THE RTM/STM1686**

The RTM/STM1686 should be used in conjunction with the DTM1716 or the DTM1717 Digital Vector Generator and the SPA1695 Power Amplifier.

**ORDERING INFORMATION**

Part Number	Operating Temp. Range	Line-to-Line Output Voltage and Format	Reference Voltage	Reference Frequency
STM1686611	-55°C to +105°C	11.8V Synchro	26V	+400Hz
STM1686612	-55°C to +105°C	90.0V Synchro	115V	+400Hz
RTM1686618	-55°C to +105°C	11.8V Resolver	26V	+400Hz

Note: For options not shown above, consult the factory.

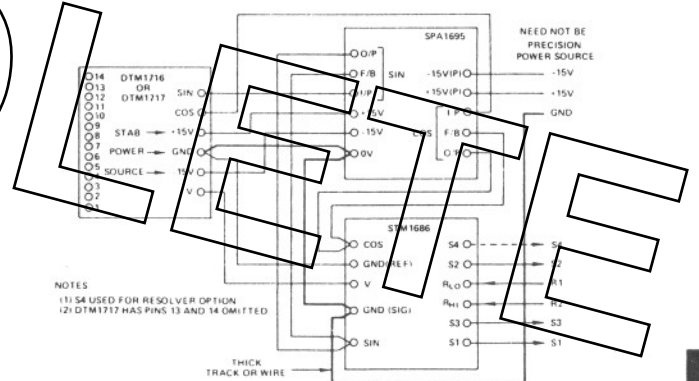
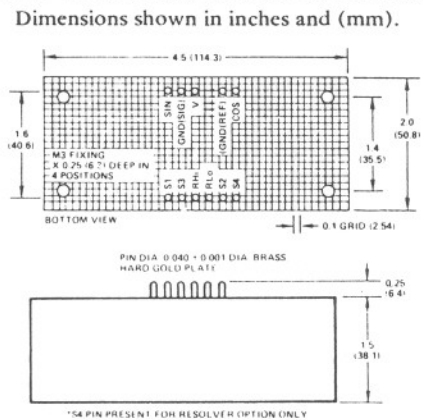

Figure 1. Diagram Showing Connection of the STM1686 to a DTM1716 or DTM1717 and SPA1695 (See Notes)

**RTM/STM1686 OUTLINE DIMENSIONS AND PIN CONNECTION DIAGRAM**



# RTM/STM 1696

SPECIFICATIONS (typical @ +25°C unless otherwise noted)

ACCURACY <sup>1</sup> (after balancing)	±2.4 arc minutes
OPERATING FREQUENCY	400Hz
LOAD CAPABILITY	5VA
OPERATING TEMPERATURE	-55°C to +105°C
STORAGE TEMPERATURE	-55°C to +125°C
VOLTAGE ISOLATION	500V dc
WEIGHT	22 ounces (620G)

NOTE:

<sup>1</sup> See STM1686 note 1.

Specifications subject to change without notice.

## APPLICATION OF THE RTM/STM1696

The RTM/STM1696 should be used in conjunction with the DSC1705 or DSC1706 Digital-to-Synchro (or Resolver) Converter and the SPA1695 Power Amplifier.

## ORDERING INFORMATION

Part Number	Operating Temp. Range	Line-to-Line Output Voltage and Format	Reference Voltage	Reference Frequency
STM1696611	-55°C to +105°C	11.8V Synchro	26V	400Hz
STM1696612	-55°C to +105°C	90.0V Synchro	115V	400Hz
RTM1696618	-55°C to +105°C	11.8V Resolver	26V	400Hz

Note: For options not shown above, consult the factory.

# RTM/STM 1736

SPECIFICATIONS (typical @ +25°C unless otherwise noted)

ACCURACY <sup>1</sup> (after balancing)	±2.4 arc minutes
OPERATING FREQUENCY	400Hz
LOAD CAPABILITY	5VA
OPERATING TEMPERATURE	-55°C to +105°C
STORAGE TEMPERATURE	-55°C to +125°C
VOLTAGE ISOLATION	500V dc
WEIGHT	19 ounces (540G)

Note:

<sup>1</sup> See STM1686 note 1.

Specifications subject to change without notice.

## APPLICATIONS OF THE RTM/STM1736

The RTM/STM1736 should be used in conjunction with the DSC1605 or the DSC1606 Digital-to-Synchro Converter and the SPA1695 Power Amplifier.

## ORDERING INFORMATION

Part Number	Operating Temp. Range	Line-to-Line Output Voltage and Format	Reference Voltage	Reference Frequency
STM1736611	-55°C to +105°C	11.8V Synchro	26V	400Hz
STM1736612	-55°C to +105°C	90.0V Synchro	115V	400Hz
RTM1736613	-55°C to +105°C	11.8V Resolver	11.8V	400Hz
RTM1736614	-55°C to +105°C	26V Resolver	26V	400Hz
RTM1736618	-55°C to +105°C	11.8V Resolver	26V	400Hz

Note: For options not shown above, consult the factory.

## NOTES FOR FIGURES 1, 2, AND 3:

- The "Sin F/B" and the "Cos F/B" pins of the SPA1695 should be connected directly of the "Sin" and "Cos" terminals on the output transformer *at the transformer*.

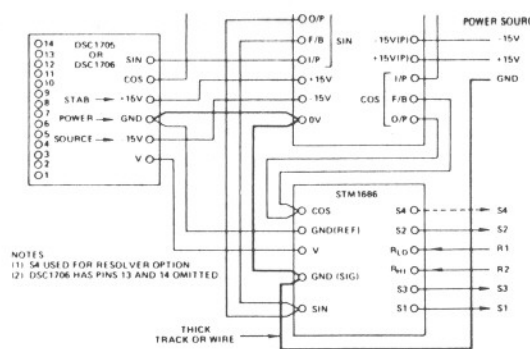

Figure 2. Diagram Showing Connection of the STM1696 to a DSC1705 or DSC1706 and SPA1695 (See Notes)

## RTM/STM1696 OUTLINE DIMENSIONS AND PIN CONNECTION DIAGRAM

Dimensions shown in inches and (mm).

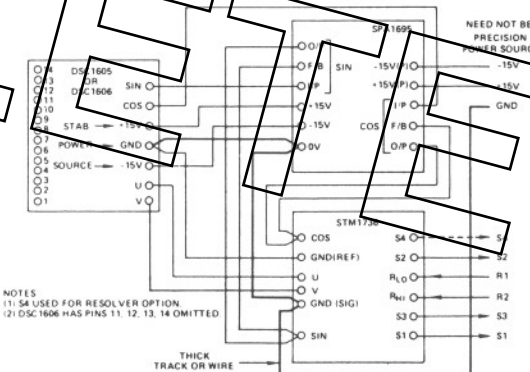
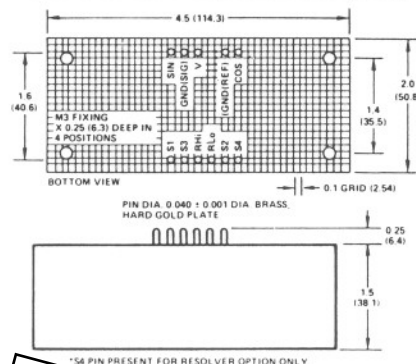
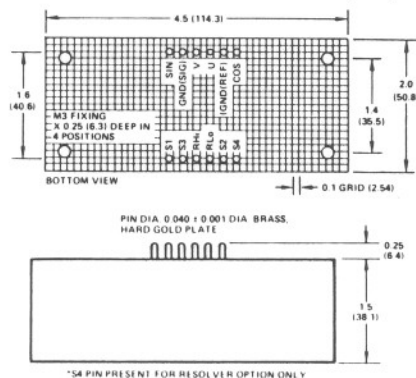

Figure 3. Diagram Showing Connection of the STM1736 to a DSC1605 or DSC1606 and SPA1695 (See Notes)

## RTM/STM1736 OUTLINE DIMENSIONS AND PIN CONNECTION DIAGRAM

Dimensions shown in inches and (mm).



This is to compensate for any drop in voltage along the connections between the "Sin O/P" and "Cos O/P" pins of the amplifier and the transformer.

- The "+15V" and "-15V" pins of the SPA1695 should be connected to a regulated power supply in order to drive the internal operational amplifiers. The "+15V(P)" and "-15V(P)" are used for the output stage and these supplies need not be a precision source, the range of voltage when considering all tolerances including ripple, should be between 14.75 and 20 volts.

- The part of the 0 volt system local to the amplifier and converter should be tapped from the "GND(SIG)" pin on the transformer and should not interconnect with any other part of the 0 volt system by any other method (see above diagram).

## STM 1687

**SPECIFICATIONS** (typical @ +25°C unless otherwise noted)

ACCURACY <sup>1</sup> (after balancing)	±2.4 arc minutes
OPERATING FREQUENCY	60Hz
LOAD CAPABILITY	5VA
OPERATING TEMPERATURE	-55°C to +105°C
STORAGE TEMPERATURE	-55°C to +125°C
VOLTAGE ISOLATION	500V dc
WEIGHT	3 lbs (1.34kg)

Note:

<sup>1</sup> See STM1686 note 1.

Specifications subject to change without notice.

### APPLICATION OF THE STM1687

The STM1687 should be used in conjunction with the DTM1716 or the DTM1717 Digital Vector Generator and the SPA1695 Power Amplifier.

### DIMENSIONS AND CONNECTIONS

The STM1687 consists of a kit of two D3953 transformers and one A10163 transformer. These should be connected as shown in Figure 4.

The dimensions are given in Figures 7 and 8.

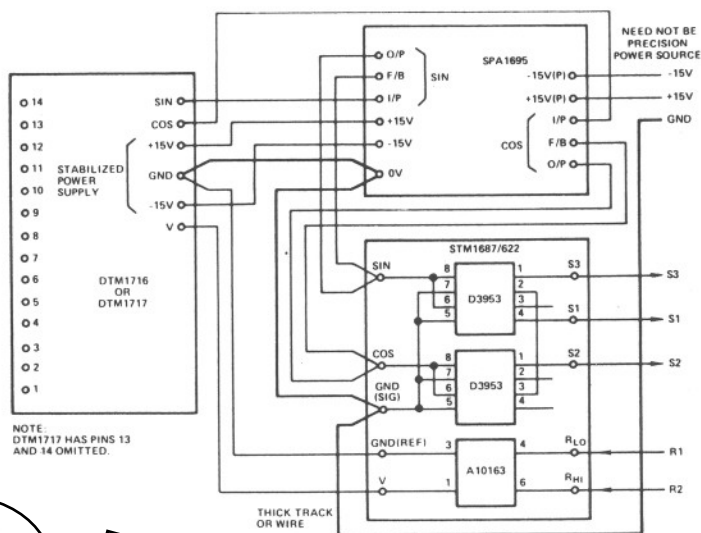

Figure 4. Diagram Showing the Connection of a STM1687 to a DTM1716 or DTM1717 and a SPA1695

### ORDERING INFORMATION

The transformer should be ordered as:

STM1687622 50/60Hz, Synchro output, 90 volt signal, 115 volt reference.

Note: For options not shown above, consult the factory.

## STM 1697

**SPECIFICATIONS** (typical @ +25°C unless otherwise noted)

ACCURACY <sup>1</sup> (after balancing)	±2.4 arc minutes
OPERATING FREQUENCY	60Hz
LOAD CAPABILITY	5VA
OPERATING TEMPERATURE	-55°C to +105°C
STORAGE TEMPERATURE	-55°C to +125°C
VOLTAGE ISOLATION	500V dc
WEIGHT	3 lbs (1.34kg)

Note:

<sup>1</sup> See STM1686 note 1.

Specifications subject to change without notice.

### APPLICATION OF THE STM1697

The STM1697 should be used in conjunction with the DSC1705 or the DSC1706 Digital to Synchro Converter and the SPA1695 Power Amplifier.

### DIMENSIONS AND CONNECTIONS

The STM1697 consists of a kit of two D3953 transformers and one A10033 transformer. These should be connected as shown in Figure 5.

The dimensions are given in Figures 7 and 8.

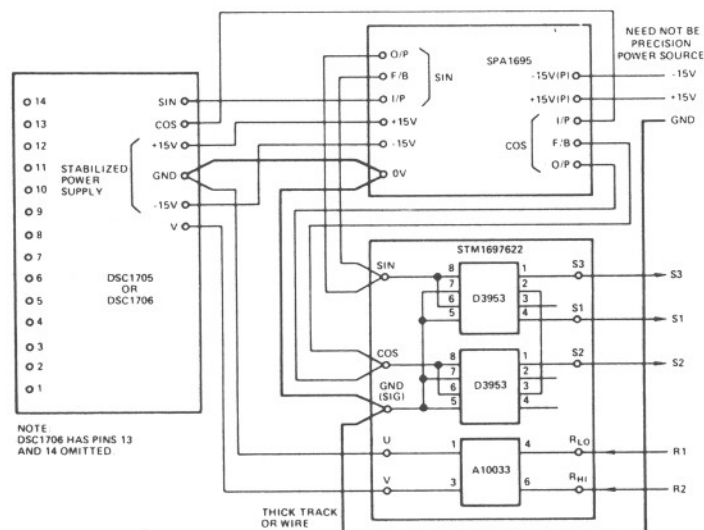

Figure 5. Diagram Showing the Connection of a STM1697 to a DSC1706 or DSC1705 and a SPA1695

### ORDERING INFORMATION

This transformer should be ordered as:

STM1697622 50/60Hz, Synchro output, 90 volt signal, 115 volt reference.

Note: For options not shown above, consult the factory.

**SPECIFICATIONS** (typical @ +25°C unless otherwise noted)

ACCURACY <sup>1</sup> (after balancing)	±2.4 arc minutes
OPERATING FREQUENCY	60Hz
LOAD CAPABILITY	5VA
OPERATING TEMPERATURE	-55°C to +105°C
STORAGE TEMPERATURE	-55°C to +125°C
VOLTAGE ISOLATION	500V dc
WEIGHT	3 lbs (1.34kg)

Note:  
<sup>1</sup> See STM1686 note 1.

Specifications subject to change without notice.

**APPLICATION OF THE STM1737**

The STM1737 should be used in conjunction with the DSC1605 or the DSC1606 Digital-to-Synchro Converter and the SPA1695 Power Amplifier.

**DIMENSIONS AND CONNECTIONS**

The STM1737 consists of a kit of two D3953 transformers and one A10033 transformer. These should be connected as shown in Figure 6.

The dimensions are given in Figures 7 and 8.

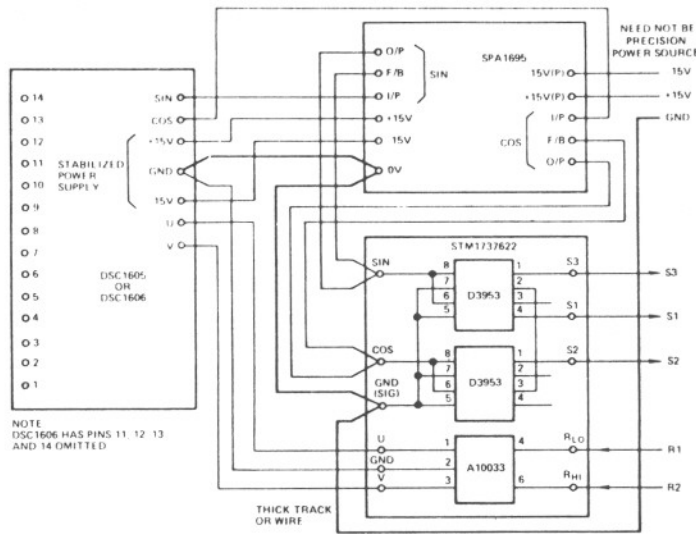

Figure 6. Diagram Showing the Connection of a STM1737 to a DSC1606 or DSC1605 and a SPA1695

**ORDERING INFORMATION**

This transformer should be ordered as:

STM1737622      50/60Hz, Synchro output, 90 volt signal, 115 volt reference.

Note: For options not shown above, consult the factory.

**OUTLINE DIMENSIONS**

Dimensions shown in inches and (mm).

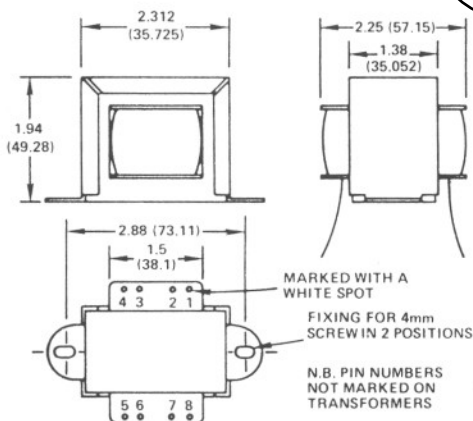

Figure 7. Outline Drawing and Dimensions of the D3953 Transformer

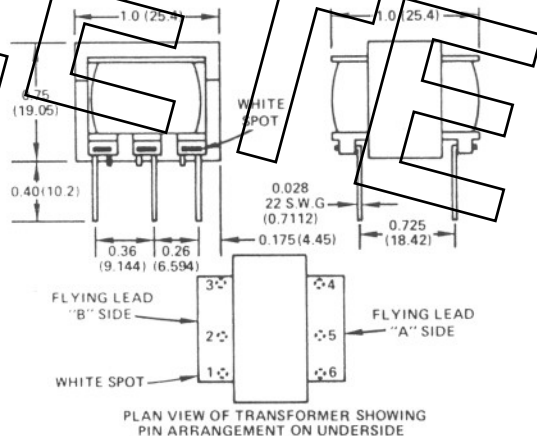

Figure 8. Outline Drawing and Dimensions of the A10163 and A10033 Transformers

**BALANCING SCOTT-T TRANSFORMERS (APPLIES ONLY TO TRANSFORMERS IN KIT FORM).**

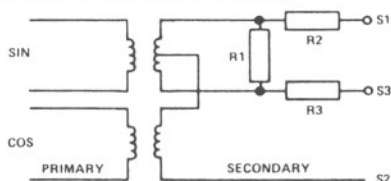

Figure 9. Diagram Showing Balancing Circuit

The Scott T transformers (two D3953 transformers) can be balanced by the following method:

Connect the primary windings of the transformers to give a known angle input of 45°. This can be done by connecting the two coils in parallel to a 7V rms supply, thus giving an equal

sine and cosine contribution.

The 3 wire output signal is then monitored on an Angle Position Indicator (e.g. API1620 or API1718) with no load attached. A resistor R1 should be connected across S1 and S3 until the API reads 45.00°.

A balanced load is then connected across S1, S2 and S3 the change in angle is monitored by the API and minimized by adding resistors (R2 and R3) in series with S1 and S3. R2 and R3 will have equal values. Increasing R2 and R3 will decrease the angle monitored by the API.

Suggested initial values for R1 is 27kΩ and for R2 and R3 is 30Ω.

The transformer modules STM1686, 1696 and 1736 are balanced before leaving the factory.