

NEW



Plug in Card Connector
Compatible with GSM 11.11 Standard

CONNECTOR

MB-0241-1

January 2012

SF11 Series

RoHS Compliant

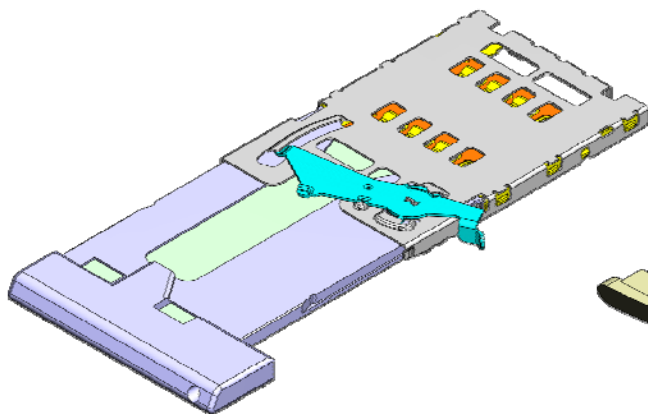

Without Detection Switch

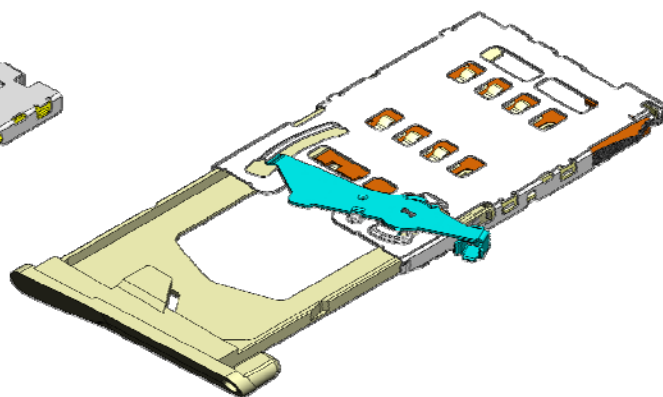

With Detection Switch

The SF11 Series is a tray type connector compatible with the GSM 11.11 standard Plug in SIM card for GSM mobile phones. (SIM: Subscriber Identification Module)

Features

- Plug in SIM card connector compatible with GSM 11.11 standard.
- Low profile, 1.9mm height.
- Available with and without card detection switch. (Refer to above images).
- Connector main body is provided in embossed tape packaging (compatible with second reflow).
- Card tray is ejected by inserting an eject-pin.
- Lock structure holds tray in place and gives a clear click feeling when the tray is fully mated.

General Specification

- | | |
|---|--|
| • No. of Contacts: 6 position | • Rated Current: 0.5A |
| • Contact Resistance: 100m Ω max.
(Switch: 1 Ω max.) | • Insulation Resistance:
Initial: 1000M Ω min.
After test: 100M Ω min. |
| • Dielectric Withstanding Voltage:
AC500Vr.m.s 1minute | • Lifetime: 5,000 times |
| • Operating Temperature:
-25 Deg. C to +85 Deg. C | |

Materials and Finishes

Component	Material / Finish
Contact	Copper alloy / 0.5 μ min. Au over Ni (contact area)
Housing	Glass filled LCP / None (UL94V-0)
Cover Frame	Stainless steel / None, Au plating over Ni (terminal area only)

Ordering Information

SF11 V 006S 4 B R****

Series Name
Tray type

SMT Mounting
V: With hold downs

No. of Contacts: 6 pos.

Embossed Product

Modification
B: Reverse, without switch
C: Standard, with switch

Terminal Finish
4: Au 0.5 μ m min.

Part Number	SJ Drawing
SF11V006S4C (Main body of connector)	SJ111358
SF11V006S4CR1000 (Embossed packaging)	SJ111359

Standard Mount Type

Unit: mm

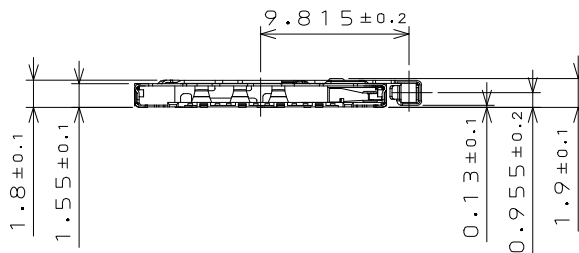
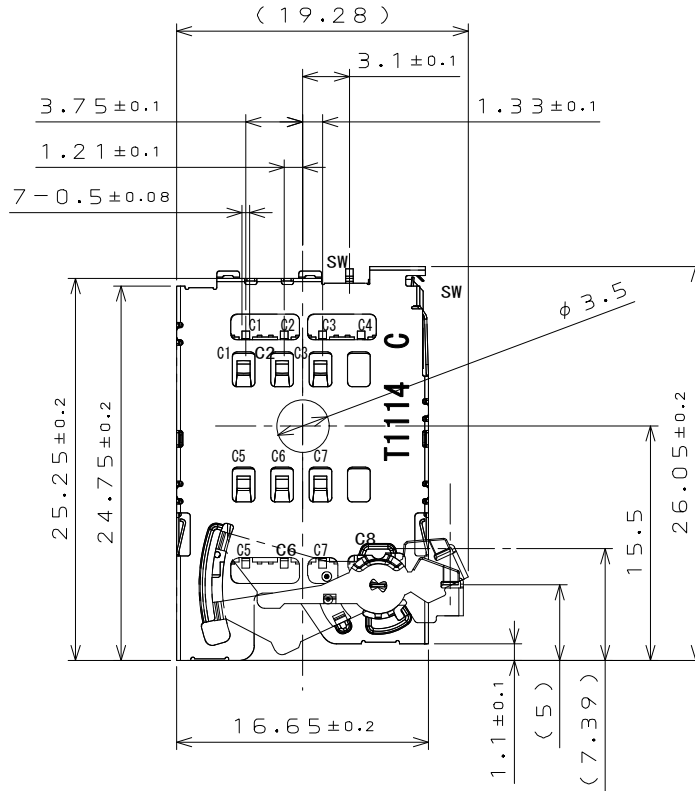

Tray Ejection

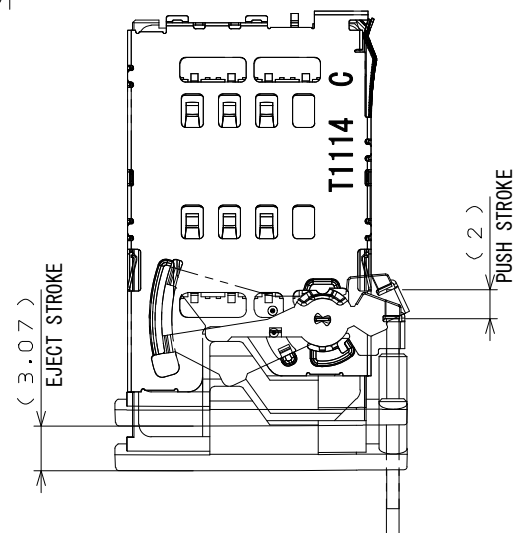

Part Number	SJ Drawing
SF11V006S4B (Main body of connector)	SJ110546
SF11V006S4BR1000 (Embossed packaging)	SJ110564

Reverse Mount Type

Unit: mm

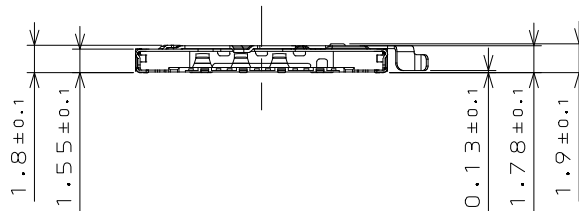
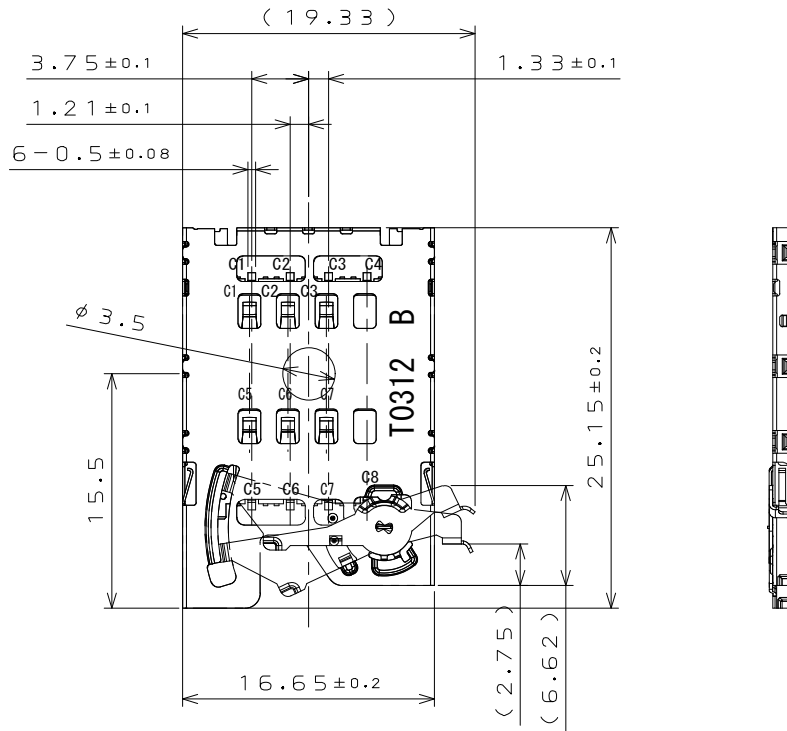

Tray Ejection

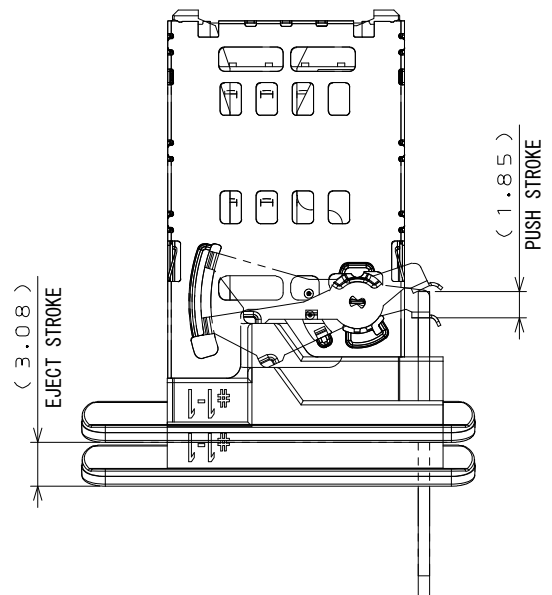

Applicable Board Dimensions

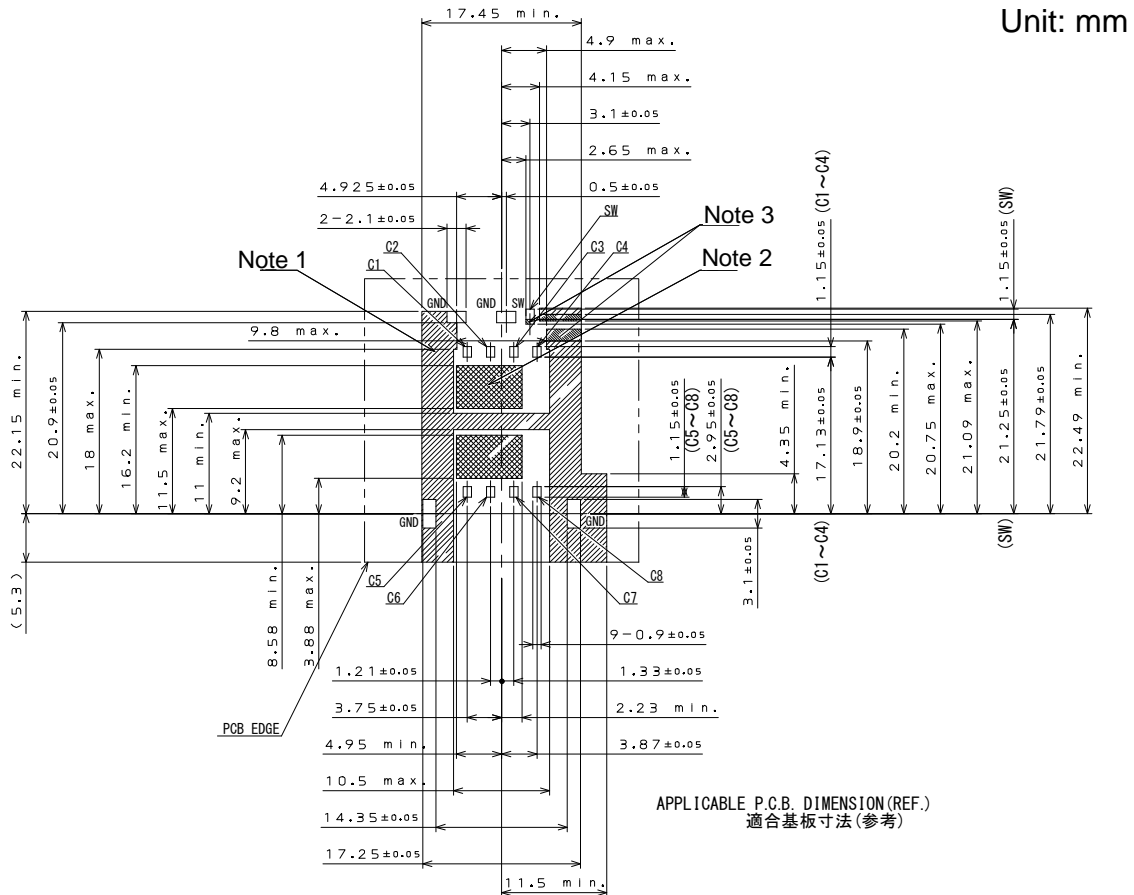

Note 1: Bottom area is metal (ground) so only ground pattern and ground via hole are allowed in this area.

Note 2: Pattern and via hole cannot be applied to this area due to moving parts.

Note 3: Bottom area is switch contact so only switch contact pattern and switch contact via is allowed in this area.

*Please refer to SJ drawing when considering this product.

Notice: Products shown in this brochure are made for the applications listed below. However, if the above-mentioned products are to be used in aerospace devices, marine cable-connection devices, atomic power control systems, medical equipment for life-support systems, or any other specific application requiring extremely high reliability, please contact JAE for further information.

Recommended applications: Computers, Office machines, Measuring devices, Telecommunication devices (Terminals, Mobile devices), AV devices, Household applications, FA devices, etc.

Japan Aviation Electronics Industry, Limited
 Product Marketing Division
 Aobadai Building, 3-1-19, Aobadai, Meguro-ku, Tokyo 153-8539
 Phone: +81-3-3780-2787 FAX: +81-3-3780-2946