

## Plug-in Signal Conditioners M-UNIT

### ENCODER SPEED TRANSMITTER

(field-programmable; built-in excitation)

#### Functions & Features

- Converts a two-phase forward and reverse rotation pulse signal with 90 degree phase difference into a forward and reverse speed signal
- Built-in excitation
- Field-selectable input type and range
- Isolation up to 2000 V AC
- High-density mounting

#### Typical Applications

- Measuring moving speed of a machine with a rotary encoder

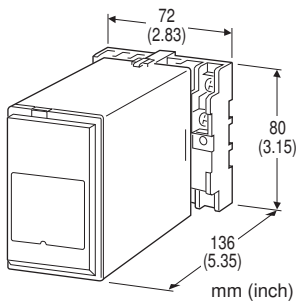

## MODEL: JRP2-[1][2]-[3][4]

### ORDERING INFORMATION

- Code number: JRP2-[1][2]-[3][4]
- Specify a code from below for each of [1] through [4]. (e.g. JRP2-76-K/Q)
- Special output range (For codes Z & 0)
- Use Ordering Information Sheet (No. ESU-1577). Factory setting (indicated below) will be used if not otherwise specified.
- Specify the specification for option code /Q (e.g. /C01/S01)

#### Factory Setting

Input type	Open collector
Pulse amplitude	----
Pulse sensing	DC coupled
Noise filter	Low
Detecting level	1V*1 (5V excitation) 2V*1 (12/24V excitation)
Frequency range	0 – 1 kHz
Input zero frequency	0 Hz
Input span frequency	1 kHz
Low-end cutout	0 Hz
Low-end cutout deadband	0.01kHz
Alarm setpoint	100%
Alarm deadband	1.00%
Alarm mode	High alarm
Linearization	Without

\*1. Detecting voltage in the internal circuit

### INPUT - Field-selectable

Open collector

Voltage pulse

RS-422 line driver pulse

Two inputs (phase A and B) are required for adequate operation of the this unit.

### [1] EXCITATION

- 1: 5 V DC @ 120 mA
- 4: 12 V DC @ 60 mA
- 7: 24 V DC @ 25 mA

### [2] OUTPUT

#### Current

- A: 4 – 20 mA DC (Load resistance 750 Ω max.)
- B: 2 – 10 mA DC (Load resistance 1500 Ω max.)
- C: 1 – 5 mA DC (Load resistance 3000 Ω max.)
- D: 0 – 20 mA DC (Load resistance 750 Ω max.)
- E: 0 – 16 mA DC (Load resistance 900 Ω max.)
- F: 0 – 10 mA DC (Load resistance 1500 Ω max.)
- G: 0 – 1 mA DC (Load resistance 15 kΩ max.)
- Z: Specify current (See OUTPUT SPECIFICATIONS)

#### Voltage

- 1: 0 – 10 mV DC (Load resistance 10 kΩ min.)
- 2: 0 – 100 mV DC (Load resistance 100 kΩ min.)
- 3: 0 – 1 V DC (Load resistance 100 Ω min.)
- 4: 0 – 10 V DC (Load resistance 1000 Ω min.)
- 5: 0 – 5 V DC (Load resistance 500 Ω min.)
- 6: 1 – 5 V DC (Load resistance 500 Ω min.)
- 4W: -10 – +10 V DC (Load resistance 2000 Ω min.)
- 5W: -5 – +5 V DC (Load resistance 1000 Ω min.)
- 0: Specify voltage (See OUTPUT SPECIFICATIONS)

**[3] POWER INPUT****AC Power**

K: 85 - 132 V AC

**DC Power**

S: 12 V DC

R: 24 V DC

V: 48 V DC

P: 110 V DC

**[4] OPTIONS**

blank: none

/Q: With options (specify the specification)

**SPECIFICATIONS OF OPTION: Q (multiple selections)****COATING (For the detail, refer to M-System's web site.)**

/C01: Silicone coating

/C02: Polyurethane coating

/C03: Rubber coating

**TERMINAL SCREW MATERIAL**

/S01: Stainless steel

**RELATED PRODUCTS**

- Programming Unit (model: PU-2x)
- PC configurator software (model: JXCON)

Downloadable at M-System's web site.

A dedicated cable is required to connect the module to the PC. Please refer to the internet software download site or the users manual for the PC configurator for applicable cable types.

**GENERAL SPECIFICATIONS****Construction:** Plug-in**Connection:** M3.5 screw terminals**Screw terminal:** Chromated steel (standard) or stainless steel**Housing material:** Flame-resistant resin (black)**Isolation:** Input to DC output to alarm output to power**Overrange output:** Approx. -15 to +115 % at 1 - 5 V**Zero adjustment:** -5 to +5 % (front)**Span adjustment:** 95 to 105 % (front)**Alarm mode:** High or Low**Alarm setpoint:** -15 - +115 %**Alarm deadband:** 0 - 20 %**Input monitor (PL1):** Red LED blinks according to the input phase A.**Input monitor (PL2):** Red LED blinks according to the input phase B.**Excitation adjustment:** 5 - 24 V DC**Software programming:** Programming Unit (model: PU-2x); (Refer to the users manual of JXCON for the adjustments)

configurable with JXCON)

- Input frequency range
- Zero and span
- Low-end cutout
- Alarm setpoint
- Output fine adjustment
- Linearrization
- Others

**Adjustments:** With DIP and Rotary switches.

- Input Type
- Noise Filter
- Pulse amplitude

(Refer to the instruction manual for details)

**Modular jack:** Connecting the PU-2x**Low-end cutout:** Specify frequency (When the low-end cutout is set to 0 Hz, the deadband is not valid.)**INPUT SPECIFICATIONS****Excitation:** Shortcircuit protection; approx. 440 mA (max.) at shortcircuit**Maximum frequency:** 200 kHz**Frequency ranges:** 0 - 0.01 Hz through 100 kHz

Note: Choose 100 kHz range to set the zero/span frequencies greater than 100 kHz.

**Minimum span:** 10 % of the selected frequency range**Minimum pulse width time requirement:** 2.5  $\mu$ sec. for both ON and OFF**■ Open Collector****Input requirements (Excitation: Sensing)**

5 V: Approx. 4 V / 1.0 mA

12 V: Approx. 9 V / 2.3 mA

24 V: Approx. 16 V / 4.7 mA

**ON resistance:**  $\leq$  200  $\Omega$ **OFF resistance:**  $\geq$  200 k $\Omega$ **Detecting level:**

1 V (5 V excitation)

2 V (12/24 V excitation)

(Detecting voltage in the internal circuit. For open collector input, be sure to re-adjust the voltage back to 1 V (5 V excitation) or 2 V (12/24 V excitation) if it has been changed for other input types.)

**Detecting pulse edge:** OFF (input monitor LED ON) to ON (LED OFF)**■ Voltage Pulse****Waveform:** Square or sine**Input impedance:** 10 k $\Omega$  min.**Pulse amplitude:** 0.1 - 100 Vp-p**Max. voltage between input terminals:** 50 V**Detecting level:** 0 - 5 V (factory setting: 2 V)

(Detecting voltage in the internal circuit.)

**Detecting pulse state:** A pulse rise detected when the input voltage goes above the detecting level (input monitor LED

ON); a pulse sink detected when it goes below the level (LED OFF).

■ **RS-422 Line Driver Pulse**

**Receiver:** Conforms to RS-422

■ **Voltage pulse waveform**

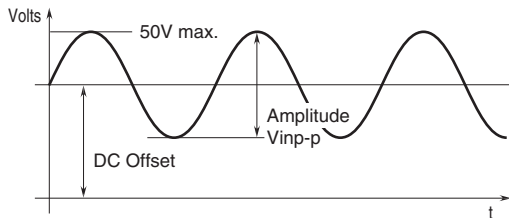

## OUTPUT SPECIFICATIONS

■ **DC Current:** 0 – 20 mA DC

**Minimum span:** 1 mA

**Offset:** Max. 1.5 times span

**Load resistance:** Output drive 15 V max.

■ **DC Voltage:** -10 – +12 V DC

**Minimum span:** 5 mV

**Offset:** Max. 1.5 times span

**Load resistance:** Output drive 10 mA max.; 5 mA for negative voltage output; at  $\geq 0.5$  V

■ **Alarm Output:** Relay contact

**Rated load:** 125 V AC @ 0.5 A ( $\cos \theta = 1$ )

30 V DC @ 0.5 A (resistive load)

**Maximum switching voltage:** 250 V AC or 125 V DC

**Maximum switching power:** 62.5 VA or 60 W

**Minimum load:** 10 mV DC @ 1 mA

**Mechanical life:**  $5 \times 10^7$  cycles (300 cycles/minute)

For maximum relay life with inductive loads, external protection is recommended.

## INSTALLATION

**Power input**

•**AC:** Operational voltage range 85 – 132 V, 47 – 66 Hz, approx. 7 VA

•**DC:** Operational voltage range: Rating  $\pm 10$  %, or 85 – 150 V for 110 V rating; ripple 10 %p-p max.; Approx. 4 W (140 mA at 24 V)

**Operating temperature:** -5 to +60°C (23 to 140°F)

**Operating humidity:** 30 to 90 %RH (non-condensing)

**Mounting:** Surface or DIN rail

**Weight:** 350 g (0.77 lb)

## PERFORMANCE in percentage of span

**Accuracy:** Input accuracy + output accuracy

**Output accuracy:**  $\pm 0.05$  % of the output range

**Input accuracy:**  $\pm 0.05$  % of the selected freq. range

The input accuracy is inversely proportional to the input

span, except fixed to  $\pm 0.05$  % with  $[\text{Freq. Range} \div \text{Span}] \leq 1$ .

[Example] Open collector input, 0 – 50 kHz

Selected Freq. Range (100 kHz)  $\div$  Input Span (50 kHz)  $\times$  Accuracy 0.05 % + Output Accuracy 0.05 % =  $\pm 0.15$  %

**Alarm setpoint accuracy:**  $\pm 0.1$  %

**Temp. coefficient:**  $\pm 0.015$  %/°C ( $\pm 0.008$  %/°F)

**Response time (0 – 90 %)**

$\leq 1$  Hz range: two pulse cycles

$\geq 10$  Hz range: 0.5 sec. + one pulse cycle

**Line voltage effect:**  $\pm 0.1$  % over voltage range

**Insulation resistance:**  $\geq 100$  M $\Omega$  with 500 V DC

**Dielectric strength:**

2000 V AC @ 1 minute (input to DC output to power)

1500 V AC @ 1 minute (input or DC output or power to alarm output)

2000 V AC @ 1 minute (circuit to ground)

## EXTERNAL VIEW

Refer to the instruction manual for the setting procedure.

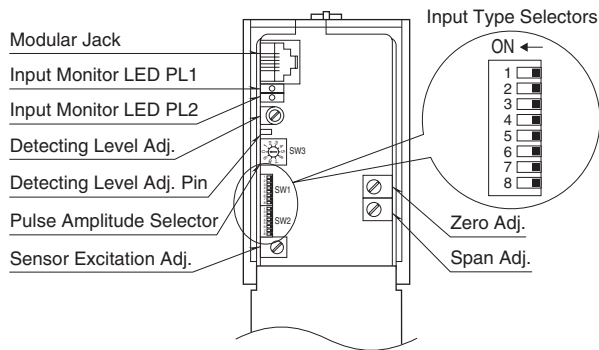

## OPERATION

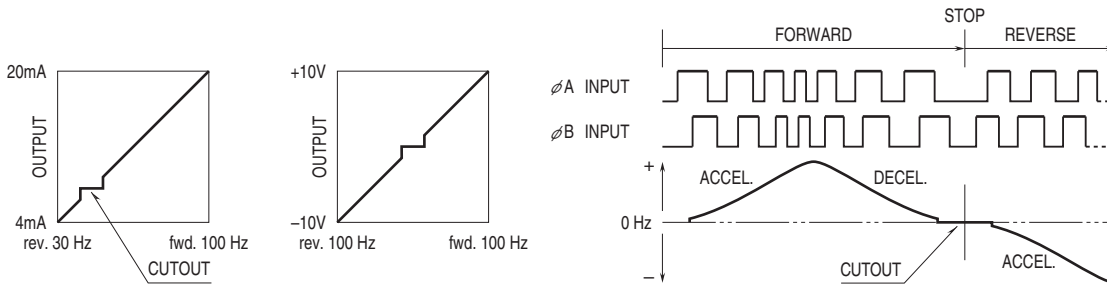

Forward Rotation: Phase A leads the Phase B by 90 degrees.  
Reverse Rotation: Phase A lags behind Phase B by 90 degrees.

## EXTERNAL DIMENSIONS & TERMINAL ASSIGNMENTS unit: mm (inch)

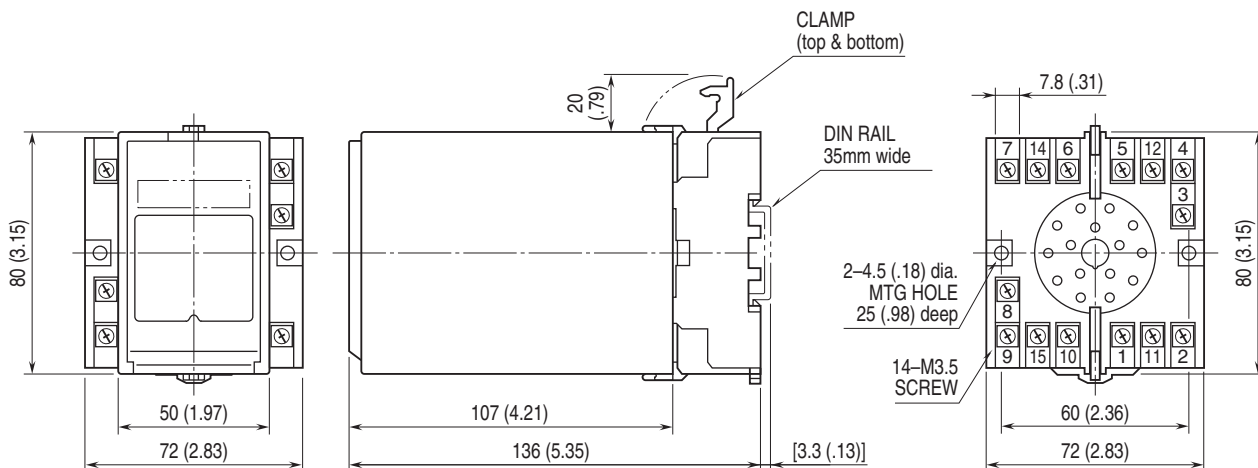

• When mounting, no extra space is needed between units.

**SCHEMATIC CIRCUITRY & CONNECTION DIAGRAM**

■ OPEN COLLECTOR or VOLTAGE PULSE INPUT

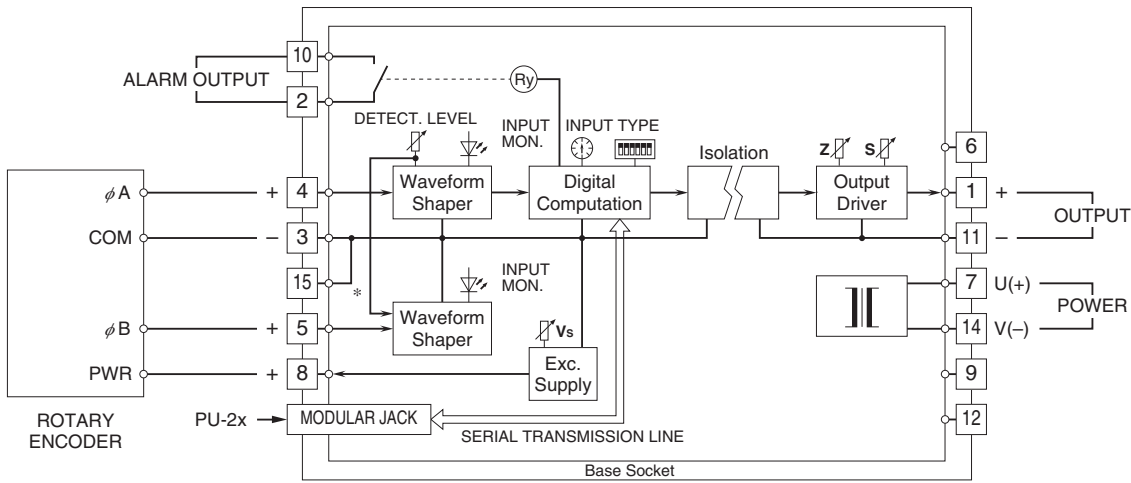

■ RS-422 LINE DRIVER INPUT

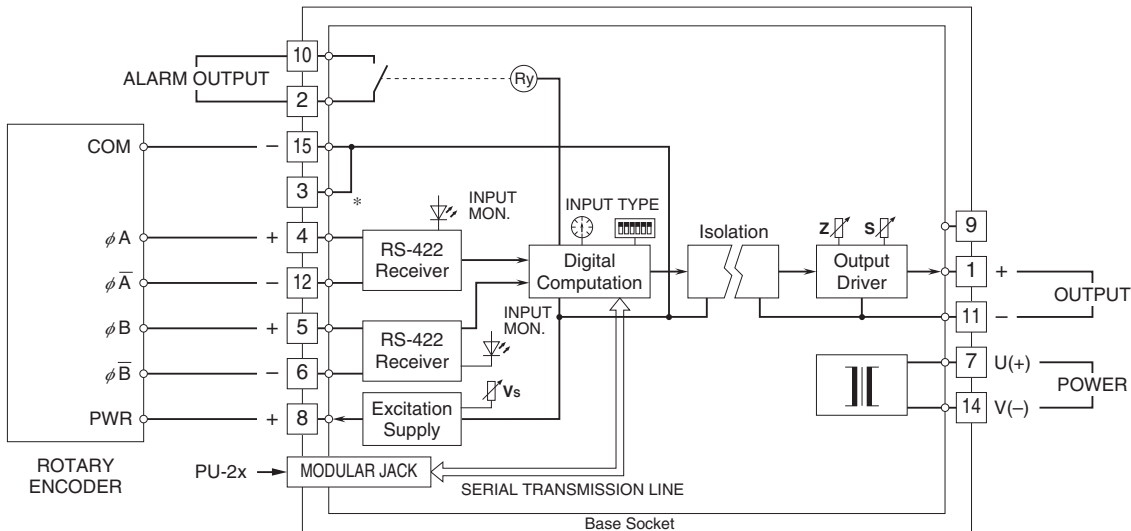

\*Terminals 3 and 15 are internally connected.  
The rotary encoder's COM terminal can be connected to either one.



Specifications are subject to change without notice.