

ohne / without

Mutter / nut
max. Einschraubtiefe 3.7 mm
thread depth max. 3.7 mm

Bolzen / bolt
max. Einschraubtiefe 5.5 mm
thread depth max. 5.5 mm

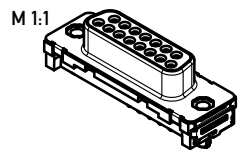
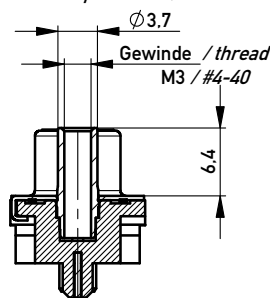
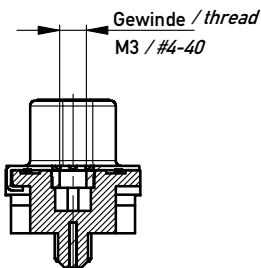
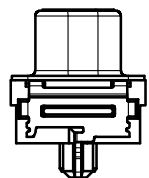

Anschlussbereich verzinkt
terminal area tin plating

Anforderungsstufe: 2
class: 2

244442	X			
244446			#4-40	
244445			M3	
244444		#4-40		
244443		M3		
Ident.-Nr. part-no.	ohne without	Mutter thread	Bolzen bolt	Bemerkung remark

Verpackt in Tray
Verpackungseinheit 36 St.
tray packaging
packaging unit 36 pcs

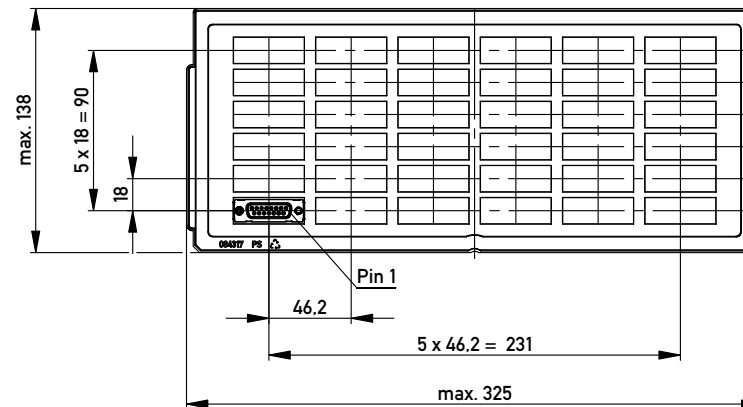

Sonstige Angaben siehe Zeichnung 204628 / Additional indications according to drawing 204628

Layoutvorschlag

recommended layout:

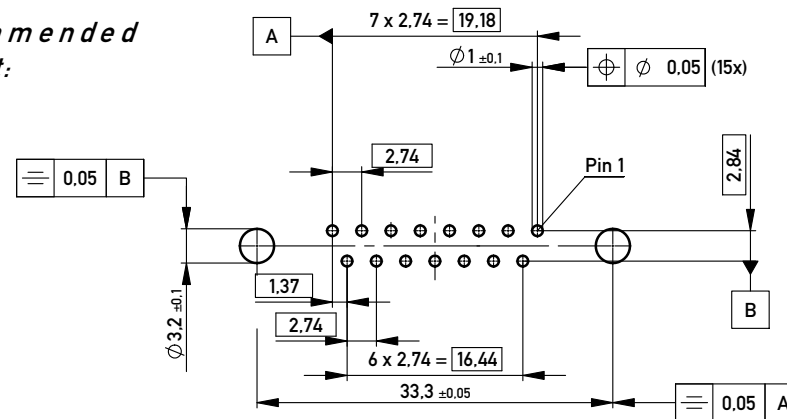

Fehlende Masse und Angaben siehe DIN 41652 / Missing information and dimensions according to DIN 41652
Sonstige Angaben siehe Fertigungsunterlagen / Additional indications according to the production documentation

Information: All rights reserved. Only for Information. To ensure that this is the latest version of this drawing, please contact one of the ERNI companies before using.	Tolerances 	Scale 2:1
	All Dimensions in mm	
www.ERNI.com Class TMCS	Designation TMC-S 15-TL-2.7-6.3-BA8 <i>TMC-S 15-TL-2.7-6.3-type 8</i>	
	224871 I A3	
a Index	12.07.2012 Date	

Copyright by ERNI GmbH
Proprietary notice pursuant to ISO 9006 to be observed.