

Remote I/O R7I4D Series

EtherCAT I/O MODULE

(NPN transistor output, 32 points each, e-CON connector)

Functions & Features

- 32 points NPN transistor output module for EtherCAT

EtherCAT® is a registered trademark and patented technology, licensed by Beckhoff Automation GmbH, Germany.

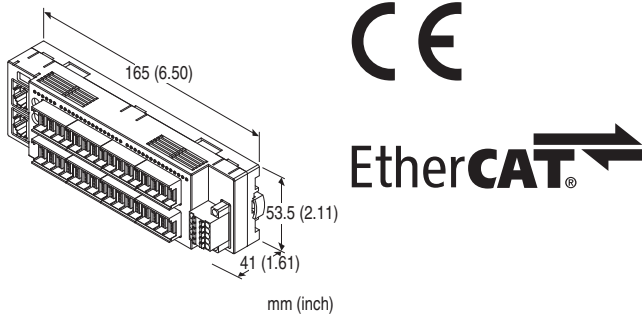

MODEL: R7I4DECT-1-DC32A-R[1]

ORDERING INFORMATION

- Code number: R7I4DECT-1-DC32A-R[1]
Specify a code from below for [1].
(e.g. R7I4DECT-1-DC32A-R/D1/Q)
- Specify the specification for option code /Q
(e.g. /C01/SET)

TERMINAL BLOCK

- 1: Tension clamp terminal block for power supply
RJ-45 Modular jack for communication
e-CON connector for I/O

I/O TYPE

DC32A: NPN transistor output, 32 points

POWER INPUT

DC Power

R: 24 V DC

(Operational voltage range 24 V ±10 %, ripple 10 %p-p max.)

[1] OPTIONS (multiple selections)

Wire Breakdown Detection

Blank: With

/D1: Without

Other Options

blank: none

/Q: With options (specify the specification)

SPECIFICATIONS OF OPTION: Q (multiple selections)

COATING (For the detail, refer to M-System's web site.)

/C01: Silicone coating

/C02: Polyurethane coating

/C03: Rubber coating

EX-FACTORY SETTING

/SET: Preset according to the Ordering Information Sheet
(No. ESU-7779-DC32)

RELATED PRODUCTS

- PC configurator software (model: R7CFG)
- ESI file

The configurator software and ESI files are downloadable at M-System's web site.

Use a commercially available Mini-B USB cable to connect the unit to a PC.

GENERAL SPECIFICATIONS

Connection

EtherCAT: RJ-45 Modular Jack

Power & Sensor excitation: Separable screwless spring terminal

Output: e-CON connector

Housing material: Flame-resistant resin (gray)

Isolation: Output or sensor excitation to EtherCAT or FE to power

Output at the loss of communication: Configurable via R7CFG

Status indicator LED: PWR, RUN, ERR, L/A IN, L/A OUT
(Refer to the instruction manual.)

Discrete Output status indicator LED: Green LED turns on with Output ON

EtherCAT COMMUNICATION

Standard: IEEE 802.3u

Transmission type: 100BASE-TX

Transmission speed: Full-duplex 100 Mbps

Transmission media: 100BASE-TX (STP cable; Category 5e)

Maximum internode length: 100 meters

Fixed address: Set with rotary switches

(The master must support MDP.)

OUTPUT SPECIFICATIONS

Common: Negative common (NPN) per 32 points

Maximum outputs applicable at once: No limit (at 24 V DC)

Sensor Excitation: 24 V DC ±10 %, ripple 5 %p-p max.,
≤ 5 A (including discrete output load charge); rated current

8 A

Rated output current: 0.2 A per point, 3.2 A per common

Residual voltage: ≤ 1.2 V

Leakage current:

With wire breakdown detection: ≤ 0.7 mA

Without wire breakdown detection: ≤ 0.1 mA

ON delay: ≤ 0.2 msec.

OFF delay: ≤ 0.5 msec.

Overload current protection function: Turns OFF the outputs when overcurrent is detected

Overheat protection function: Turns OFF the outputs when overheat is detected

Diagnostic function: When the overcurrent, overheat and open load (disconnection) are detected, notifies to the status bit of upper input area. Refer to the users manual for details

Note: Status is disabled with option code: /D1 (without wire breakdown detection).

(When driving an inductive load, connect a diode in parallel with the load.)

INSTALLATION

Current consumption

•DC at 24 V DC: Approx. 55 mA

Operating temperature: -10 to +55°C (14 to 131°F)

Storage temperature: -20 to +65°C (-4 to +149°F)

Operating humidity: 30 to 90 %RH (non-condensing)

Atmosphere: No corrosive gas or heavy dust

Mounting: Surface or DIN rail (35 mm rail)

Weight: 180 g (0.40 lb)

PERFORMANCE

Insulation resistance: ≥ 100 M Ω with 500 V DC

Dielectric strength: 1500 V AC @ 1 minute

(output or sensor excitation to EtherCAT or FE to power)

STANDARDS & APPROVALS

EU conformity:

EMC Directive

EMI EN 61000-6-4

EMS EN 61000-6-2

RoHS Directive

EN 50581

FUNCTIONS

■ WIRE BREAKDOWN DETECTION

The function to notifies to the status bit of upper input area in case of open load (disconnection) of discrete output is detected.

Connect output load under 10 k Ω .

Pull-down resistor is mounted to detect disconnection so weak leakage current flows even when the output is OFF. Status bit is disabled and pull-down resistor is not mounted with option code: /D1 (without wire breakdown detection).

PC CONFIGURATOR

The following parameters can be set with using PC Configurator Software (model: R7CFG)

Refer to the users manual for the R7CFG for detailed operation of the software program.

■ CHANNEL INDIVIDUAL SETTING

PARAMETER	SETTING RANGE	DEFAULT
Unused setting (output only)	CH enabled, CH disabled	CH enabled

■ CHANNEL BATCH SETTING

PARAMETER	SETTING RANGE	DEFAULT
Output at communication error	Output hold, Output clear	Output hold

MODEL: R7I4DECT-1-DC32A

EXTERNAL VIEW

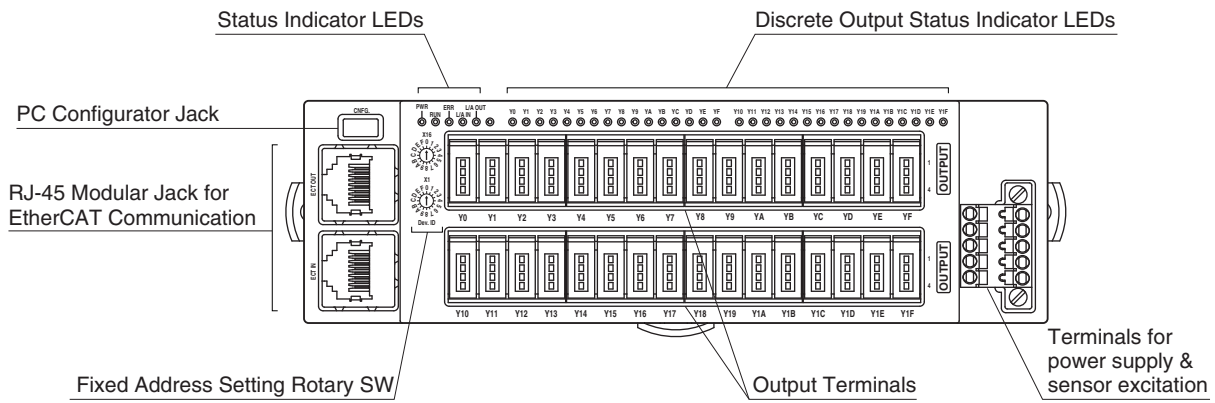

TERMINAL ASSIGNMENTS

■ OUTPUT TERMINAL ASSIGNMENT

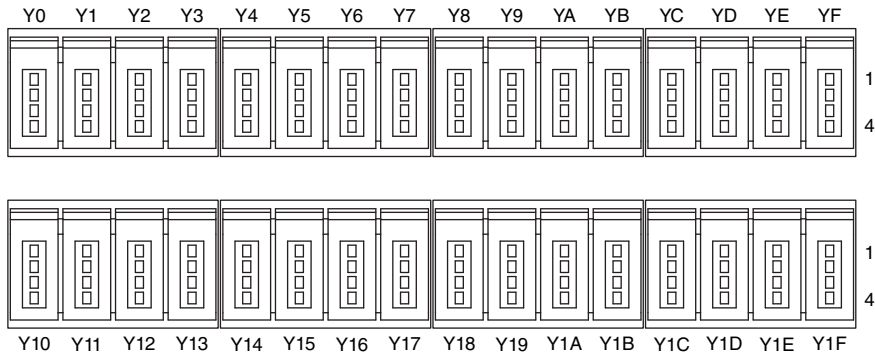

PIN No.	ID	FUNCTION	PIN No.	ID	FUNCTION
Y0	1	+24V	Y8	1	+24V
	2	NC		2	NC
	3	NC		3	NC
	4	Y0		4	Y8
Y1	1	+24V	Y9	1	+24V
	2	NC		2	NC
	3	NC		3	NC
	4	Y1		4	Y9
Y2	1	+24V	YA	1	+24V
	2	NC		2	NC
	3	NC		3	NC
	4	Y2		4	YA
Y3	1	+24V	YB	1	+24V
	2	NC		2	NC
	3	NC		3	NC
	4	Y3		4	YB
Y4	1	+24V	YC	1	+24V
	2	NC		2	NC
	3	NC		3	NC
	4	Y4		4	YC
Y5	1	+24V	YD	1	+24V
	2	NC		2	NC
	3	NC		3	NC
	4	Y5		4	YD
Y6	1	+24V	YE	1	+24V
	2	NC		2	NC
	3	NC		3	NC
	4	Y6		4	YE
Y7	1	+24V	YF	1	+24V
	2	NC		2	NC
	3	NC		3	NC
	4	Y7		4	YF

PIN No.	ID	FUNCTION	PIN No.	ID	FUNCTION
Y10	1	+24V	Y18	1	+24V
	2	NC		2	NC
	3	NC		3	NC
	4	Y10		4	Y18
Y11	1	+24V	Y19	1	+24V
	2	NC		2	NC
	3	NC		3	NC
	4	Y11		4	Y19
Y12	1	+24V	Y1A	1	+24V
	2	NC		2	NC
	3	NC		3	NC
	4	Y12		4	Y1A
Y13	1	+24V	Y1B	1	+24V
	2	NC		2	NC
	3	NC		3	NC
	4	Y13		4	Y1B
Y14	1	+24V	Y1C	1	+24V
	2	NC		2	NC
	3	NC		3	NC
	4	Y14		4	Y1C
Y15	1	+24V	Y1D	1	+24V
	2	NC		2	NC
	3	NC		3	NC
	4	Y15		4	Y1D
Y16	1	+24V	Y1E	1	+24V
	2	NC		2	NC
	3	NC		3	NC
	4	Y16		4	Y1E
Y17	1	+24V	Y1F	1	+24V
	2	NC		2	NC
	3	NC		3	NC
	4	Y17		4	Y1F

■ POWER SUPPLY, SENSOR EXCITATION

Cable connector: TFMC1,5 / 5-STF-3,5
(Phoenix Contact) (included in the package)

Applicable wire size: 0.2 – 1.5 mm²; stripped length 10 mm

Recommended solderless terminal

- AI0,25–10YE 0.25 mm² (Phoenix Contact)
- AI0,34–10TQ 0.34 mm² (Phoenix Contact)
- AI0,5–10WH 0.5 mm² (Phoenix Contact)
- AI0,75–10GY 0.75 mm² (Phoenix Contact)
- A1–10 1.0 mm² (Phoenix Contact)
- A1,5–10 1.5 mm² (Phoenix Contact)

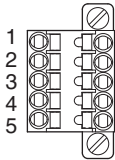

- | | |
|--------------|-------------------|
| 1. PWR+ | Power Supply |
| 2. PWR- | Power Supply |
| 3. FE | Functional earth |
| 4. SNSR.EXC+ | Sensor excitation |
| 5. SNSR.EXC- | Sensor excitation |

Note: The numbers marked on the connector have no relationship to the pin number of the unit.
Wire according to the instruction manual of the unit.

RESPONSE TIME

- Output module

Response time is time from when a step (0 to 100%) output signal is received by the communication CPU of the output module (slave) until when its output reaches 90% of the final value.

T_{COM} : EtherCAT communication cycle set by the host device (master)
(The cycle is determined in accordance with the system configuration and settings.)

T_{OUT} : Output module response time \leq Delay time of output internal processing (T_d) (communication cycle \times 1) + 0 msec. (T_e) + Delay time of output circuit (T_f)

ex.) When EtherCAT communication cycle: 1 msec. and delay time of output: ON,
Output module response time(T_{OUT}): Delay time of output internal processing (1 msec.) (communication cycle \times 1) + 0 msec. + Delay time of output circuit (0.2 msec.) = 1.2 [msec.]

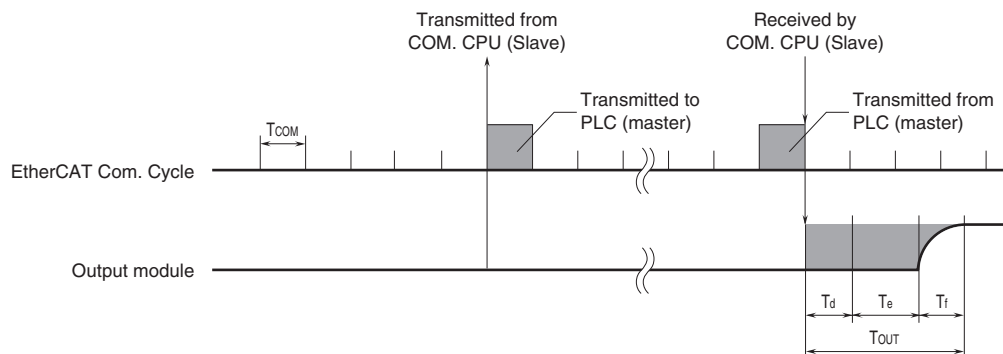

I/O DATA DESCRIPTIONS

■ DESCRETE OUTPUT MODEULE

• Output Area Objects

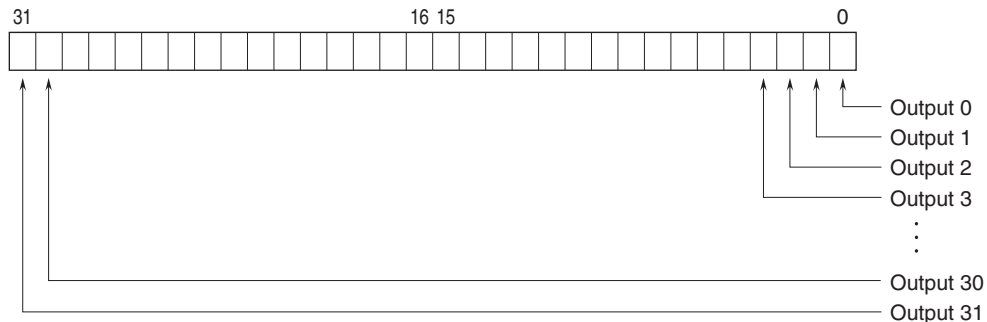

0: OFF 1: ON

■ STATUS (Input Area Object)

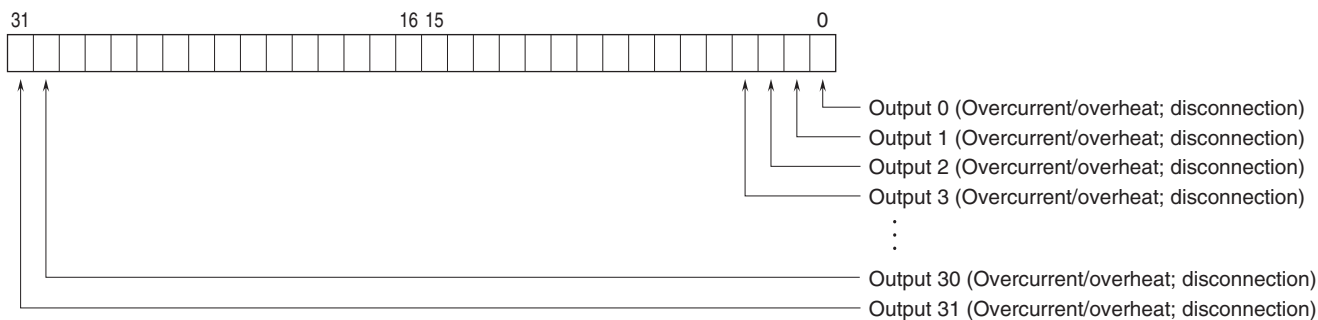

0: Normal
1: Detected the overcurrent/overheat and disconnection

Note: Status is disabled with option code: /D1 (without wire breakdown detection).

EXTERNAL DIMENSIONS unit: mm (inch)

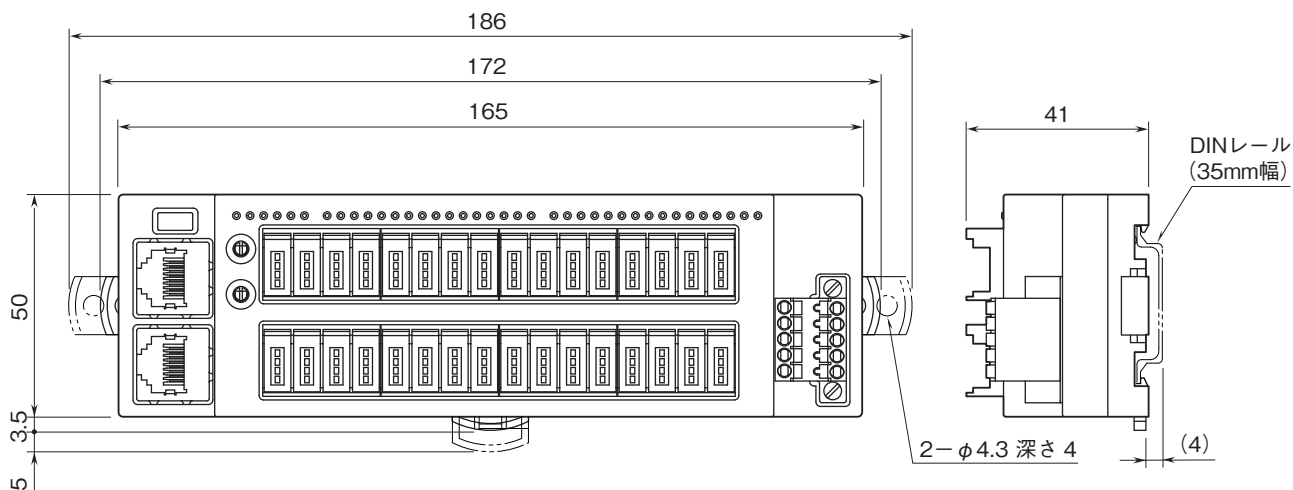

MOUNTING REQUIREMENTS unit: mm (inch)

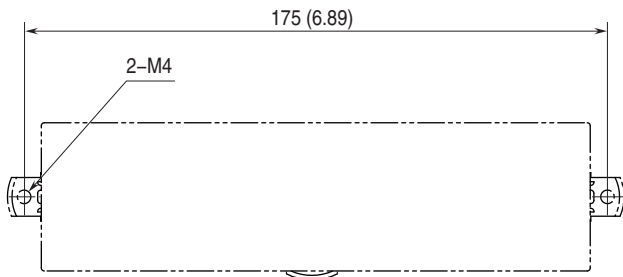

SCHEMATIC CIRCUITRY & CONNECTION DIAGRAM

Note: In order to improve EMC performance, bond the FE terminal to ground.

Caution: FE terminal is NOT a protective conductor terminal.

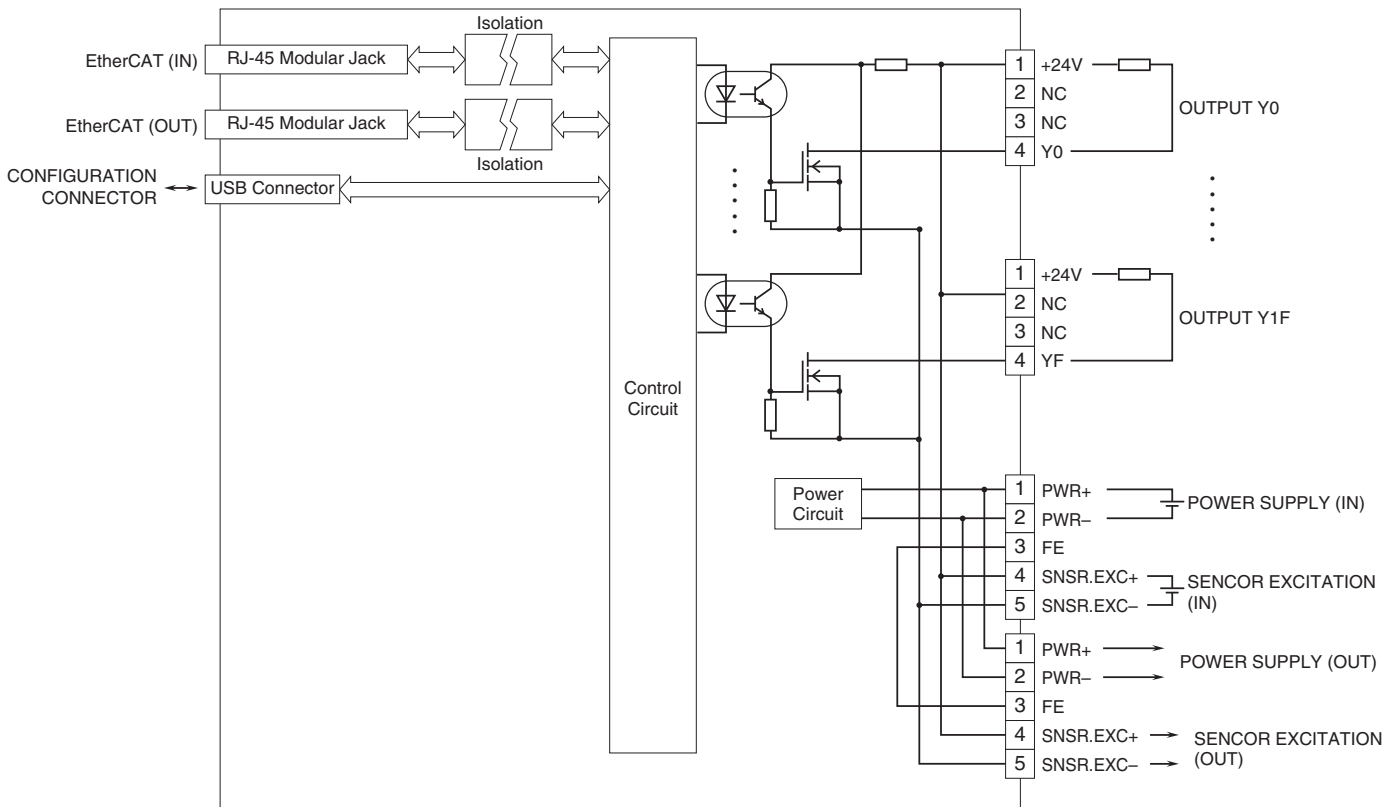

Specifications are subject to change without notice.