

## Super-space-saving Signal Conditioners M3S-UNIT Series

### RTD TRANSMITTER

#### Functions & Features

- Accepts direct input from an RTD and provides a standard process signal
- Linearization
- Burnout protection
- Universal AC/DC power input
- Fast response type available
- High-density mounting
- Power indicator LED

#### Typical Applications

- Long distance transmission between the RTD and the transmitter
- Combination with intrinsic safety barriers

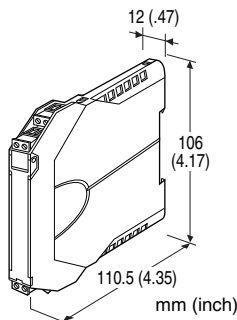

### MODEL: M3SRS-[1][2]-[3][4]

#### ORDERING INFORMATION

- Code number: M3SRS-[1][2]-[3][4]
- Specify a code from below for each [1] through [4].  
(e.g. M3SRS-4A-R/K/BL/Q)
- Temperature range (e.g. 0 - 500°C)
- Special output range (For codes Z & 0)
- Specify the specification for option code /Q  
(e.g. /C01)

#### [1] INPUT RTD (2- or 3-wire)

**1:** JPt 100 (JIS'89)

(Usable range: -200 to +500°C, -328 to +932°F; min.span: 50°C, 90°F)

**3:** Pt 100 (JIS'89)

(Usable range: -200 to +650°C, -328 to +1202°F; min.span: 50°C, 90°F)

**4:** Pt 100 (JIS'97, IEC)

(Usable range: -200 to +850°C, -328 to +1562°F; min.span: 50°C, 90°F)

**5:** Pt 50 Ω (JIS'81)

(Usable range: -200 to +500°C, -328 to +932°F; min.span: 100°C, 180°F)

**6:** Ni 508.4 Ω

(Usable range: -50 to +200°C, -58 to +392°F; min.span: 30°C, 54°F)

**0:** Specify

Note: Consult M-System for 2-wire RTD

#### [2] OUTPUT

##### Current

**A:** 4 - 20 mA DC (Load resistance 550 Ω max.)

**B:** 2 - 10 mA DC (Load resistance 1100 Ω max.)

**C:** 1 - 5 mA DC (Load resistance 2200 Ω max.)

**D:** 0 - 20 mA DC (Load resistance 550 Ω max.)

**E:** 0 - 16 mA DC (Load resistance 680 Ω max.)

**F:** 0 - 10 mA DC (Load resistance 1100 Ω max.)

**G:** 0 - 1 mA DC (Load resistance 11 kΩ max.)

**Z:** Specify current (See OUTPUT SPECIFICATIONS)

##### Voltage

**1:** 0 - 10 mV DC (Load resistance 10 kΩ min.)

**2:** 0 - 100 mV DC (Load resistance 100 kΩ min.)

**3:** 0 - 1 V DC (Load resistance 1000 Ω min.)

**4:** 0 - 10 V DC (Load resistance 10 kΩ min.)

**5:** 0 - 5 V DC (Load resistance 5000 Ω min.)

**6:** 1 - 5 V DC (Load resistance 5000 Ω min.)

**4W:** -10 - +10 V DC (Load resistance 10 kΩ min.)

**5W:** -5 - +5 V DC (Load resistance 5000 Ω min.)

**0:** Specify voltage (See OUTPUT SPECIFICATIONS)

#### [3] POWER INPUT

##### AC Power

**M2:** 100 - 240 V AC (Operational voltage range 90 - 264 V, 47 - 66 Hz)

##### DC Power

**R:** 24 V DC

(Operational voltage range 24 V ±10 %, ripple 10 %p-p max.)

##### Universal

**AD:** 100 - 240 V AC / 24 - 240 V DC (universal)

(Operational voltage range 90 - 264 V AC, 47 - 66 Hz / 21.6 - 264 V DC, ripple 10 %p-p max.)

#### [4] OPTIONS (multiple selections)

##### Response Time (0 - 90 %)

**blank:** Standard (≤ 0.5 sec.)

**/K:** Fast Response (Approx. 25 msec.)

##### Burnout

**blank:** Upscale burnout

**/BL:** Downscale burnout

##### Other Options

**blank:** none

**/Q:** Option other than the above (specify the specification)

## SPECIFICATIONS OF OPTION: Q

**COATING (For the detail, refer to M-System's web site.)**

/C01: Silicone coating

/C02: Polyurethane coating

/C03: Rubber coating

## GENERAL SPECIFICATIONS

**Construction:** Small-sized front terminal structure

**Connection:** Euro type connector terminal

**Applicable wire size:** 0.2 to 2.5 mm<sup>2</sup>, stripped length 8 mm

**Housing material:** Flame-resistant resin (gray)

**Isolation:** Input to output to power

**Overrange output:** Approx. -10 to +120 % at 1 - 5 V

**Zero adjustment:** -2 to +2 % (front)

**Span adjustment:** 98 to 102 % (front)

**Burnout:** Upscale standard;downscale optional

**Linearization:** Standard

**Power LED:** Green light turns on when the power is supplied.

## INPUT SPECIFICATIONS

**Maximum leadwire resistance:** 200 Ω per wire (3-wire)

**Sensing current:** 1.3 mA (Pt); 0.7 mA (Ni 508.4 Ω)

## OUTPUT SPECIFICATIONS

■ **DC Current:** 0 - 20 mA DC

**Minimum span:** 1 mA

**Offset:** Max. 1.5 times span

**Load resistance:** Output drive 11 V max.

■ **DC Voltage:** -10 - +11 V DC

**Minimum span:** 5 mV

**Offset:** Max. 1.5 times span

**Load resistance:** Output drive 1 mA maximum; at  $\geq 0.5$  V

## INSTALLATION

**Power consumption**

•AC:

Approx. 2 VA at 100 V

Approx. 3 VA at 200 V

Approx. 4 VA at 264 V

•DC: Approx. 1 W

**Operating temperature:** -10 to +55°C (14 to 131°F)

**Operating humidity:** 30 to 90 %RH (non-condensing)

**Mounting:** DIN rail

**Weight:** 100 g (3.53 oz)

## PERFORMANCE in percentage of span

**Accuracy:**  $\pm 0.2$  %

**Temp. coefficient:**  $\pm 0.015$  %/°C ( $\pm 0.008$  %/°F)

**Burnout response:**  $\leq 10$  sec.

**Line voltage effect:**  $\pm 0.1$  % over voltage range

**Insulation resistance:**  $\geq 100$  MΩ with 500 V DC

**Dielectric strength:** 2000 V AC @1 minute (input to output to power to ground)

## STANDARDS & APPROVALS

**EU conformity:**

EMC Directive

EMI EN 61000-6-4

EMS EN 61000-6-2

Low Voltage Directive

EN 61010-1

Installation Category II

Pollution Degree 2

Input or output to power: Reinforced insulation (300 V)

Input to output: Basic insulation (300 V)

RoHS Directive

EN 50581

## EXTERNAL VIEW

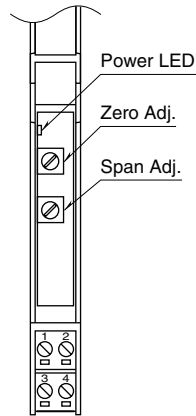

## EXTERNAL DIMENSIONS & TERMINAL ASSIGNMENTS unit: mm (inch)

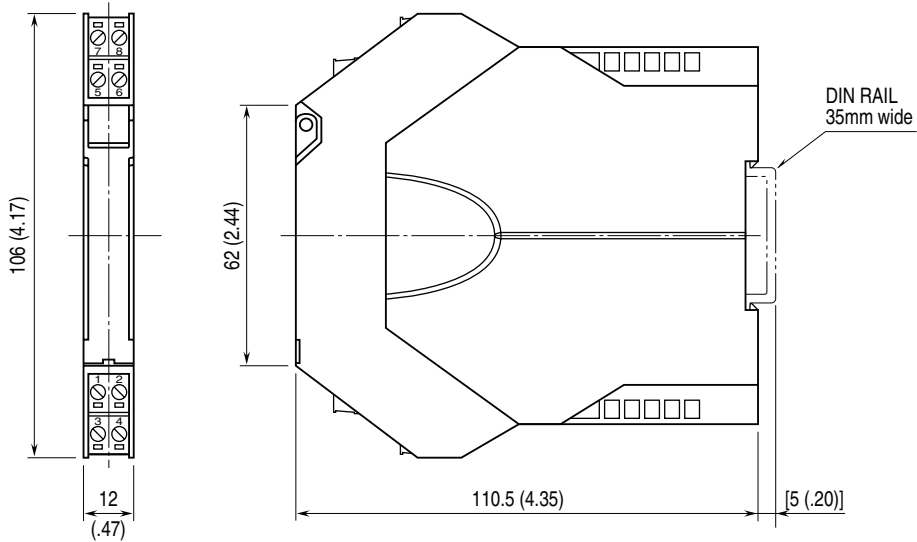

• When mounting, no extra space is needed between units.

## SCHEMATIC CIRCUITRY & CONNECTION DIAGRAM

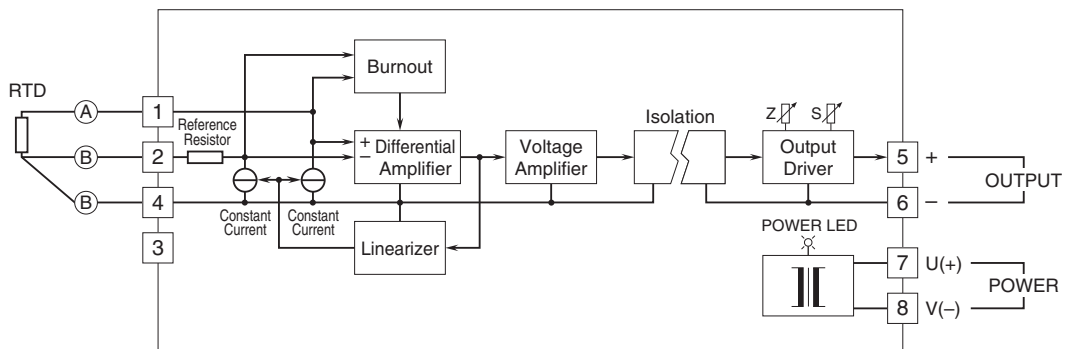

Specifications are subject to change without notice.