



LEOPARD IMAGING INC

Rev 1.0

LI-XAVIER-KIT-IMX377CS-X Data Sheet

Key Features

- Compatible with Nvidia Jetson AGX Xavier Developer Kit
- MIPI CSI-2 interface
- Support up to two 4-lane cameras or three 2-lane cameras
- Sony Diagonal 7.81 mm (Type 1/2.3) CMOS Image Sensor IMX377CQT
- Active pixels: 4024H x 3036V
- Pixel size: 1.55 um x 1.55 um
- Color camera
- Length of the I-PEX cable: 300mm
- Support multiple length cables
- Support IR cut switch
- Support CS lens
- Provide customization services
- Part#:
 - (1 cam) [LI-XAVIER-KIT-IMX377CS](#)
 - (2 cam) [LI-XAVIER-KIT-IMX377CS-D](#)
 - (3 cam) [LI-XAVIER-KIT-IMX377CS-T](#)



Lens Spec

- Model: ES0522F.IR
- Focal length: 5.0 mm
- Aperture, F/#: 2.2
- FOV (D/H/V): 87 °/ 76 °/43 °
- TV Distortion: < -8%
- Mount Type: CS

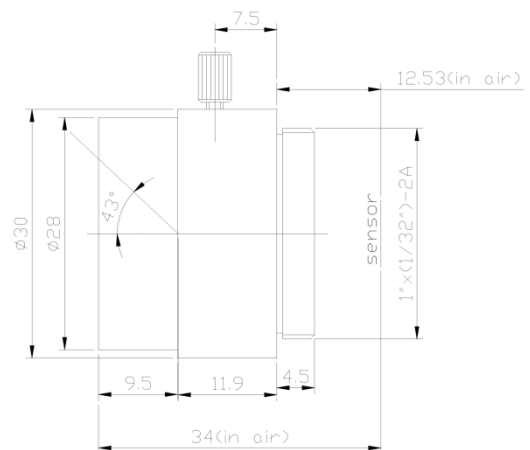

BOM

Nvidia AGX Xavier Developer Kit not included

#	Items	QTY
1	LI-JTX1-MIPI-ADPT	1
2	LI-IMX377-MIPI-CS	1,2 or 3
3	FAW-1233-03 cable	1,2 or 3



Leopard Imaging Inc.

48820 Kato Rd, Suite 100B, Fremont, CA 94538, USA
 Phone: +1-408-263-0988
 Fax: +1-408-217-1960
 Email: sales@leopardimaging.com
 Website: www.leopardimaging.com

LI-XAVIER-KIT-IMX377CS

BOM

#	Items	QTY
1	LI-JTX1-MIPI-ADPT	1
2	LI-IMX377-MIPI-CS	1
3	FAW-1233-03 cable	1



LI-XAVIER-KIT-IMX377CS-D

BOM

#	Items	QTY
1	LI-JTX1-MIPI-ADPT	1
2	LI-IMX377-MIPI-CS	2
3	FAW-1233-03 cable	2



LI-XAVIER-KIT-IMX377CS-T

BOM

#	Items	QTY
1	LI-JTX1-MIPI-ADPT	1
2	LI-IMX377-MIPI-CS	3
3	FAW-1233-03 cable	3



Dimensions

LI-IMX377-MIPI-CS

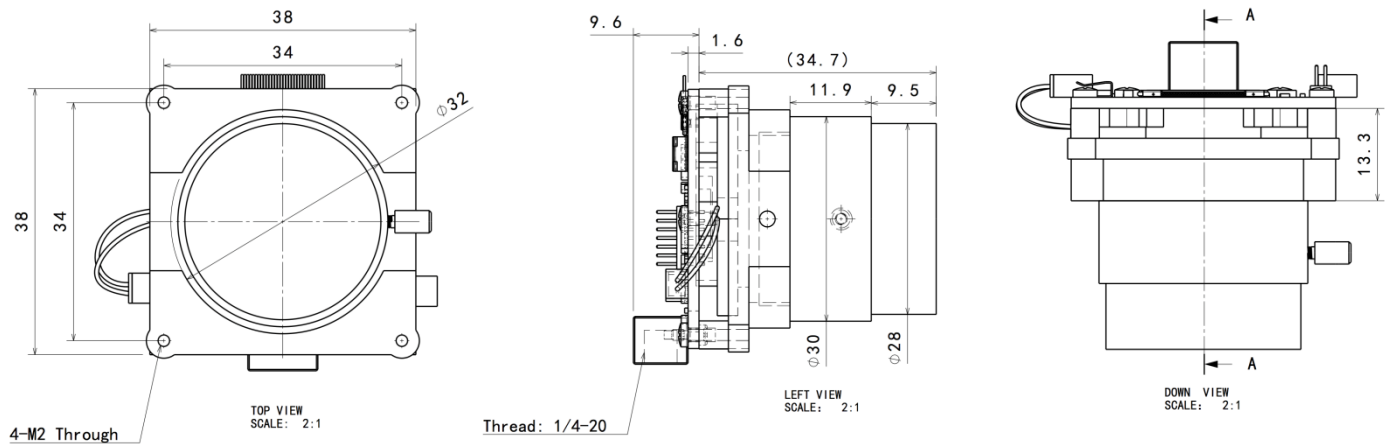

LI-JTX1-MIPI-ADPT

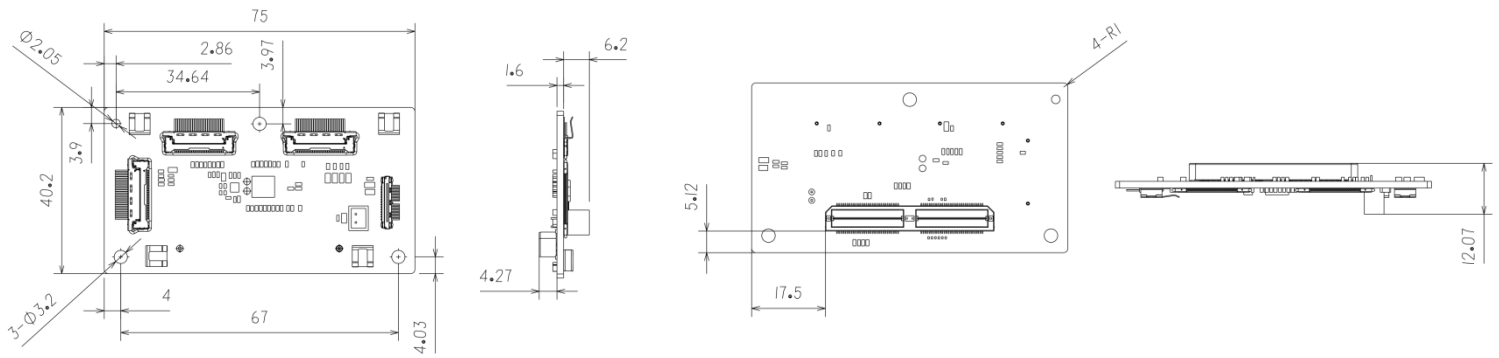

FAW-1233-03

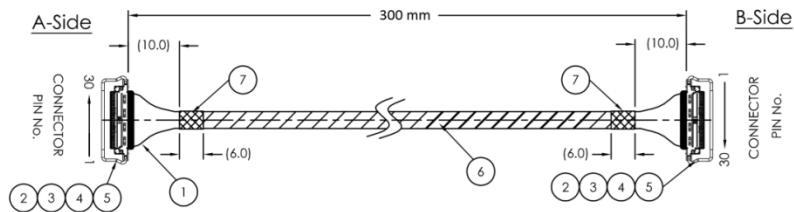

Leopard Imaging Inc.

48820 Kato Rd, Suite 100B, Fremont, CA 94538, USA
 Phone: +1-408-263-0988
 Fax: +1-408-217-1960
 Email: sales@leopardimaging.com
 Website: www.leopardimaging.com

LI-JTX1-MIPI-ADPT

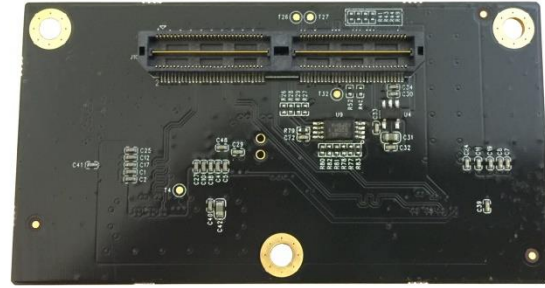
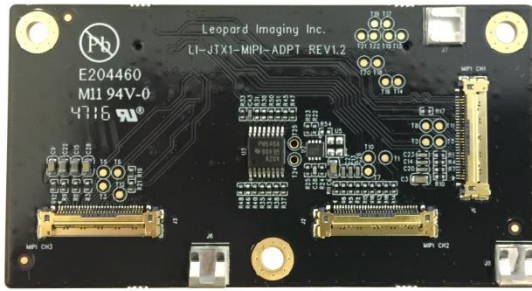

Interfaces

Interface J1

- Part#: 20525-030E-02C
- Number of Positions: 30
- Pitch: 0.4mm
- Mating I-PEX cable: FAW-1233-03 (300mm)

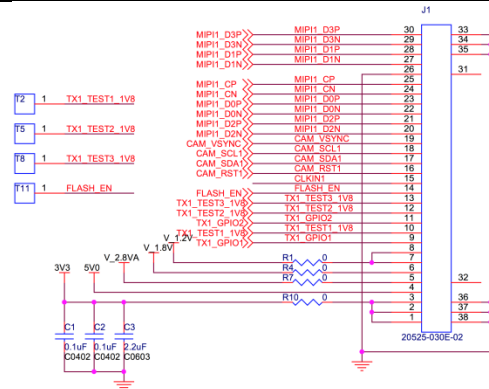

Interface J2

- Part#: 20525-030E-02C
- Number of Positions: 30
- Pitch: 0.4mm
- Mating I-PEX cable: FAW-1233-03 (300mm)

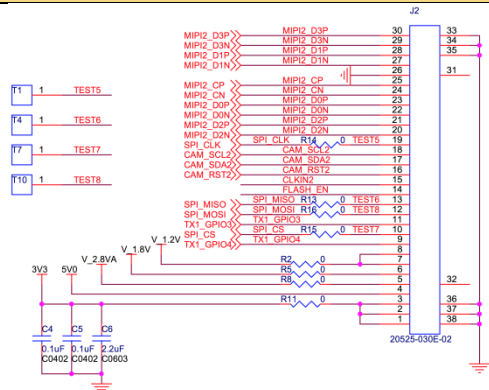

Interface J3

- Part#: 20525-030E-02C
- Number of Positions: 30
- Pitch: 0.4mm
- Mating I-PEX cable: FAW-1233-03 (300mm)

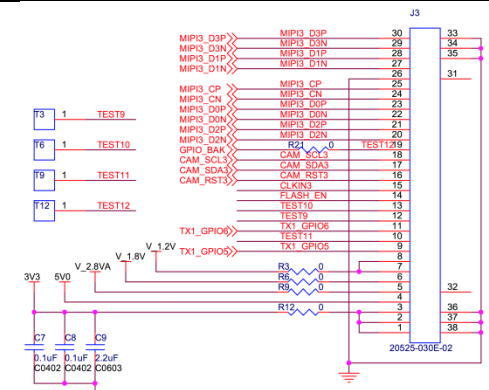

Leopard Imaging Inc.

48820 Kato Rd, Suite 100B, Fremont, CA 94538, USA
 Phone: +1-408-263-0988
 Fax: +1-408-217-1960
 Email: sales@leopardimaging.com
 Website: www.leopardimaging.com

Interface J10

- Part#: QTH-060-01-L-D-A
- Number of Positions: 120
- Number of Rows: 2
- Pitch: 0.5 mm

Vertical Mating connector of Jetson TX1 J22 QTH-060-01-D-A

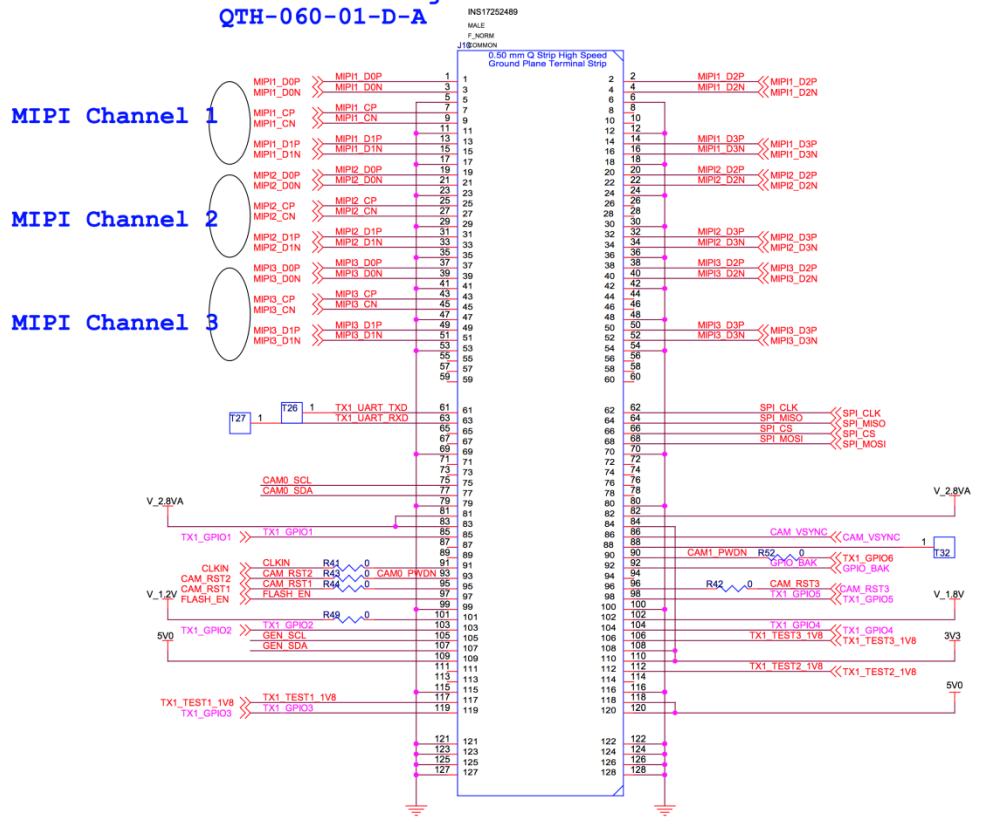

Leopard Imaging Inc.

48820 Kato Rd, Suite 100B, Fremont, CA 94538, USA
 Phone: +1-408-263-0988
 Fax: +1-408-217-1960
 Email: sales@leopardimaging.com
 Website: www.leopardimaging.com

LI-IMX377-MIPI-CS

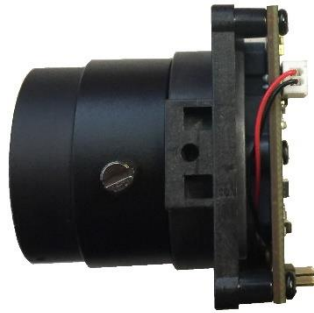

Camera Spec	
Image Sensor	Sony Diagonal 7.81 mm (Type 1/2.3) CMOS Image Sensor IMX377CQT
Optical format	1/2.3"
Number of active pixels	4024 (H) x 3036(V)
Pixel size	1.55um (H) x 1.55um (V)
Color or Mono	Color
Interface	MIPI interface
Lens mount	CS
IR switcher	Support
Weight	56 g

Interfaces

Interface J1:

- Part#: 20525-030E-02C
- Number of Positions: 30
- Pitch: 0.4mm
- Mating I-PEX cable: FAW-1233-03 (300mm)

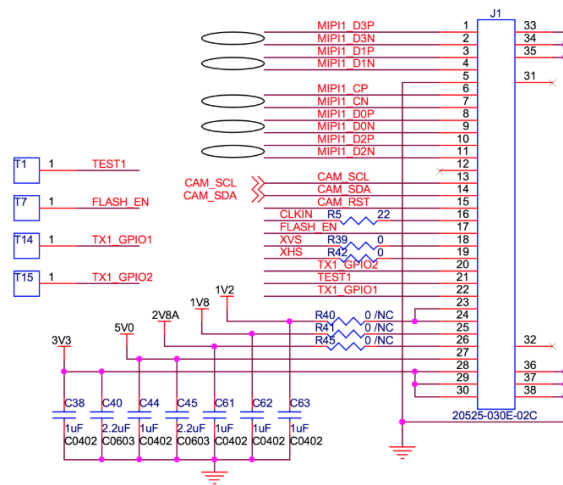

Interface J3:

- Part#: 1734829-2
- Number of Positions: 2
- Pitch: 1.25mm

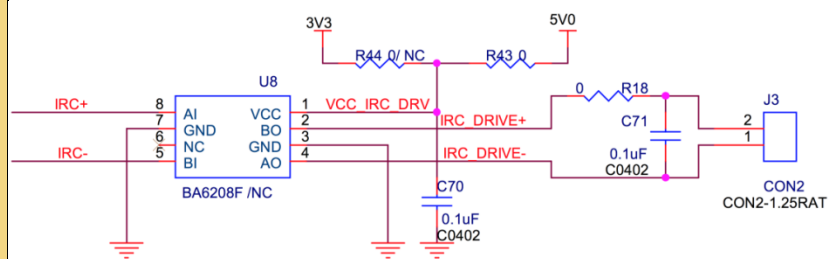

Leopard Imaging Inc.

48820 Kato Rd, Suite 100B, Fremont, CA 94538, USA
 Phone: +1-408-263-0988
 Fax: +1-408-217-1960
 Email: sales@leopardimaging.com
 Website: www.leopardimaging.com

Absolute Maximum Ratings

◆ Supply voltage (Analog)	V_{ADD}^{*1}	-0.3 to +3.3	V
◆ Supply voltage (Digital 1)	V_{DDD1}^{*2}	-0.5 to +2.0	V
◆ Supply voltage (Digital 2)	V_{DDD2}^{*3}	-0.5 to +3.3	V
◆ Input voltage (Digital)	V_I	-0.3 to $V_{DDD2} + 0.3$	V
◆ Output voltage (Digital)	V_O	-0.3 to $V_{DDD2} + 0.3$	V
◆ Guaranteed operating temperature	T_{OPR}	-10 to +75	°C
◆ Storage guarantee temperature	T_{STG}	-30 to +80	°C
◆ Performance guarantee temperature	T_{SPEC}	-10 to +60	°C

Recommended Operating Conditions

◆ Supply voltage (Analog)	V_{ADD}^{*1}	2.8 ± 0.1	V
◆ Supply voltage (Digital 1)	V_{DDD1}^{*2}	1.2 ± 0.1	V
◆ Supply voltage (Digital 2)	V_{DDD2}^{*3}	1.8 ± 0.1	V
◆ Input voltage (Digital)	V_I	-0.1 to $V_{DDD2} + 0.1$	V
◆ Output voltage (Digital)	V_O	-0.1 to $V_{DDD2} + 0.1$	V

*1 V_{ADD} : V_{DDSUB} , V_{DDHCM} , V_{DDHPX} , V_{DDHDA} , V_{DDHCP} (2.8 V power supply)

*2 V_{DDD1} : V_{DDLNC1} to 2, V_{DDLSC1} to 2, V_{DDLPL1} to 3, V_{DDLIF1} to 2 (1.2 V power supply)

*3 V_{DDD2} : V_{DDMIO} (1.8 V power supply)

Spectral Sensitivity Characteristics

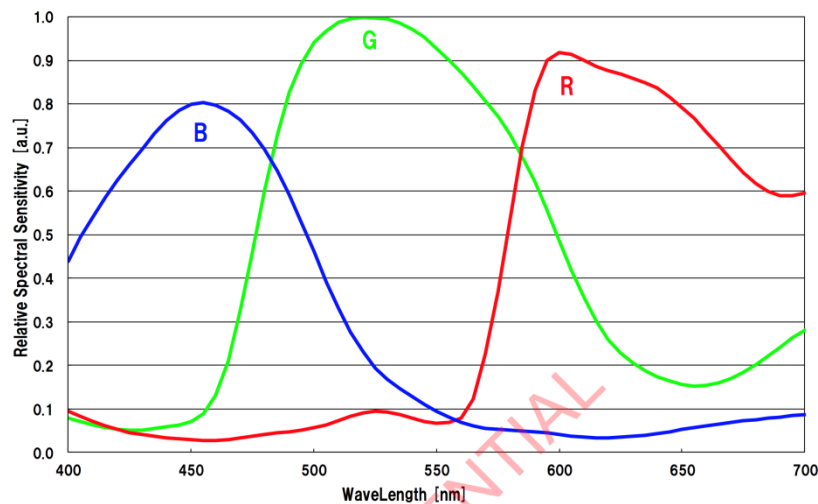

DC Characteristics

Current Consumption and Gain Variable Range

($V_{ADD} = 2.9\text{ V}$, $V_{DDD1} = 1.3\text{ V}$, $V_{DDD2} = 1.9\text{ V}$, $T_j = 60\text{ }^\circ\text{C}$, Reference Gain (0 dB), approximately 12.35 M pixels readout (MODE0), 34.97 frame/s)

Item	Symbol	Min.	Typ.	Max.	Unit	Remarks
Current consumption (Analog)	I_{ADD}	—	—	91	mA	
Current consumption (Digital 1)	I_{DDD1}	—	—	256	mA	
Current consumption (Digital 2)	I_{DDD2}	—	—	1	mA	
Standby current (Analog)	I_{ADDSTB}	—	—	150	μA	In the dark
Standby current (Digital 1)	$I_{DDD1STB}$	—	—	40	mA	In the dark
Standby current (Digital 2)	$I_{DDD2STB}$	—	—	50	μA	In the dark
PGA gain variable range	PGAG	0	—	27	dB	

Supply Voltage and I/O Voltage

Item		Pins	Symbol	Min.	Typ.	Max.	Unit
Supply voltage	Analog	V_{DDSUB} , V_{DDHCM} , V_{DDHPX} , V_{DDHDA} , V_{DDHCP}	V_{ADD}	2.70	2.80	2.90	V
	Digital 1	$V_{DDL1CN1}$ to 2, $V_{DDL1LSC1}$ to 2, $V_{DDL1LPL1}$ to 3, $V_{DDL1LIF1}$ to 2	V_{DDD1}	1.10	1.20	1.30	V
	Digital 2	V_{DDMIO}	V_{DDD2}	1.70	1.80	1.90	V
Digital input voltage	SDA, SCL		V_{IH1}	$0.7 \times V_{DDD2}$	—	1.9	V
			V_{IL1}	-0.3	—	$0.3 \times V_{DDD2}$	V
	XCLR, INCK		V_{IH2}	$0.65 \times V_{DDD2}$	—	$V_{DDD2} + 0.3$	V
			V_{IL2}	-0.3	—	$0.35 \times V_{DDD2}$	V



AC Characteristics

INCK, XCLR

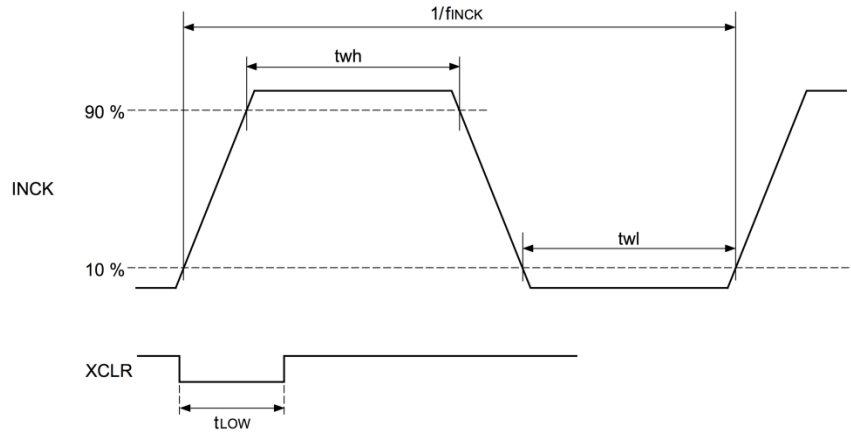

Item	Symbol	Min.	Typ.	Max.	Unit
INCK clock frequency	f_{INCK}	6	—	27	MHz
INCK Low level pulse width	t_{wl}	5	—	—	ns
INCK High level pulse width	t_{wh}	5	—	—	ns
Clock duty	—	40	50	60	%
XCLR Low level pulse width	t_{LOW}	100	—	—	ns



Leopard Imaging Inc.

48820 Kato Rd, Suite 100B, Fremont, CA 94538, USA
 Phone: +1-408-263-0988
 Fax: +1-408-217-1960
 Email: sales@leopardimaging.com
 Website: www.leopardimaging.com

I²C Communication

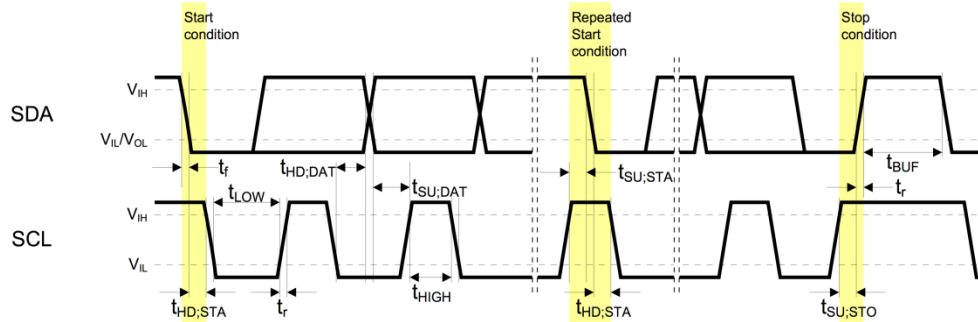

I²C Specification

Item	Symbol	Min.	Typ.	Max.	Unit	Remarks
Low level input voltage	V_{IL}	-0.3	—	$0.3 \times V_{DD2}$	V	
High level input voltage	V_{IH}	$0.7 \times V_{DD2}$	—	1.9	V	
Low level output voltage	V_{OL}	0	—	$0.2 \times V_{DD2}$	V	$V_{DD2} < 2\text{ V}$, Sink 3 mA
Output fall time	t_{of}	—	—	250	ns	Load 10 pF to 400 pF, $0.7 \times V_{DD2}$ to $0.3 \times V_{DD2}$
Input current	i_i	-10	—	10	μA	$0.1 \times V_{DD2}$ to $0.9 \times V_{DD2}$
Input capacitance of SCL / SDA	C_i	—	—	10	pF	

I²C AC Characteristics

Item	Symbol	Min.	Typ.	Max.	Unit
SCL clock frequency	f_{SCL}	0	—	400	kHz
Hold time (Start Condition)	$t_{HD,STA}$	0.6	—	—	μs
Low period of the SCL clock	t_{LOW}	1.3	—	—	μs
High period of the SCL clock	t_{HIGH}	0.6	—	—	μs
Set-up time (Repeated Start Condition)	$t_{SU,STA}$	0.6	—	—	μs
Data hold time	$t_{HD,DAT}$	0	—	0.9	μs
Data set-up time	$t_{SU,DAT}$	100	—	—	ns
Rise time of both SDA and SCL signals	t_r	—	—	300	ns
Fall time of both SDA and SCL signals	t_f	—	—	300	ns
Set-up time (Stop Condition)	$t_{SU,STO}$	0.6	—	—	μs
Bus free time between a STOP and START Condition	t_{BUF}	1.3	—	—	μs



Power-on Sequence

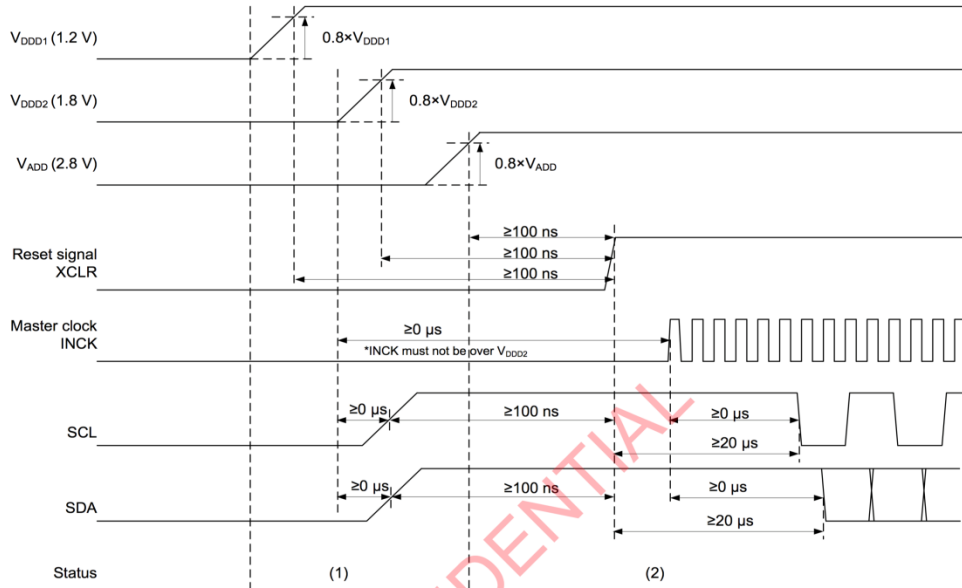

Period name	Remarks
(1) Power stabilization period	All input signals are set to Low level. There are no constraints of the power-on sequence with V _{ADD} , V _{DD1} and V _{DD2} .
(2) Register communication period for standby cancel	Wait 100 ns after the last power supply in V _{ADD} , V _{DD1} and V _{DD2} . Then set XCLR to "H" and start the standby cancel sequence.

Slew Rate Limitation of Power-on Sequence

Conform the slew rate limitation shown below when power supply change 0 V to each voltage (0 % to 100 %) in power-on sequence.

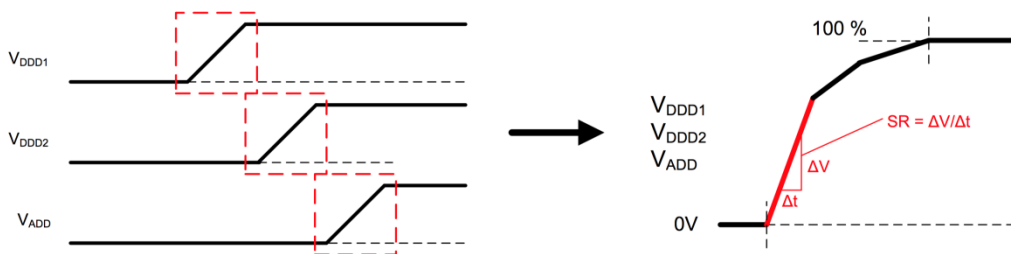

Slew rate of power supply

Item	Symbol	Power supply	Min.	Max.	Unit	Remarks
Slew rate	SR	V _{DD1} (1.2 V)	—	25	mV/μs	
		V _{DD2} (1.8 V)	—	25	mV/μs	
		V _{ADD} (2.8 V)	—	25	mV/μs	



Leopard Imaging Inc.

48820 Kato Rd, Suite 100B, Fremont, CA 94538, USA
 Phone: +1-408-263-0988
 Fax: +1-408-217-1960
 Email: sales@leopardimaging.com
 Website: www.leopardimaging.com

Power-off Sequence

Make sure that all input signals are set to LOW level in the area of (2).

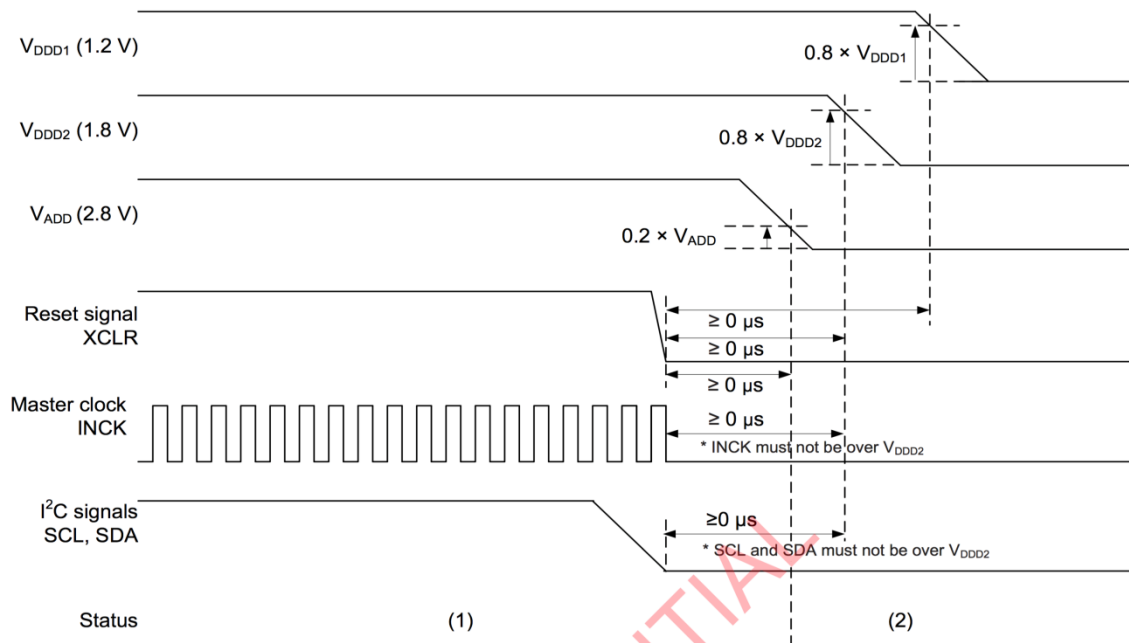

Period name	Remarks
(1) Pixel output period	Pixel signal output period
(2) Power-off period	Turn the power supplies off after all input signals are set to "Low" level except SCL and SDA. Set SCL and SDA to "Low" level at the same time with turning off the power supply of V _{DD2} . There are no constraints of the power-off sequence with V _{ADD} , V _{DD1} , and V _{DD2} .



Leopard Imaging Inc.

48820 Kato Rd, Suite 100B, Fremont, CA 94538, USA
 Phone: +1-408-263-0988
 Fax: +1-408-217-1960
 Email: sales@leopardimaging.com
 Website: www.leopardimaging.com