

The following is an application guide for utilization of the MASW-000822-12770T in conjunction with a supplied sample board from M/A-COM Tech. The guide will review the operation of the T/R using a single positive supply as well as other optional dual polarity supplies.

The MASW-000822-12770T is a T/R switch with two PIN diodes in series in a common anode configuration. The switch die along with matching components are mounted in a standard 3mm MLP 16 lead package (Figure 1). The switch die utilizes M/A-COM Technology Solutions patented HMIC™ process. The backside of the switch die is thermally grounded while being electrically isolated. The excellent power handling of the die is achieved through specific techniques using unique thermal conductive epoxy embedded in the die. This allows the heat to be transferred from the series connected device to ground while maintaining electrical isolation. The large backside of the pad of the package is both thermal and electrical ground. Figure 2 shows the electrical/thermal schematic of the device.

The sample board is made of Rogers RO4350 material 10mils thick dielectric with a added layers to increase the board thickness to 62mils for handling, rigidity and connector mounting. There are on-board bias networks incorporated to accommodate biasing the device without the use of expensive external bias tees. Figure 3 shows the standard board layout with component selection for optimize performance up to 6 GHz.

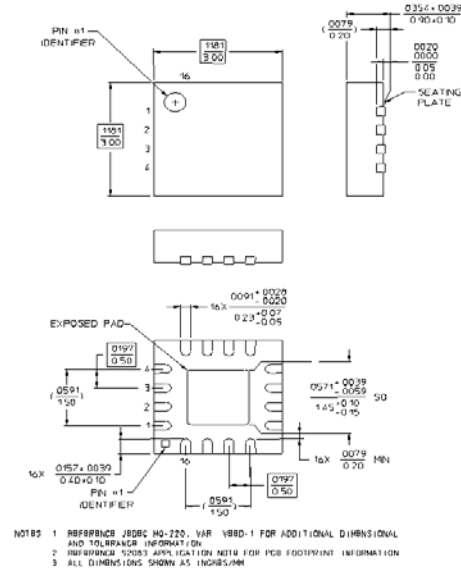
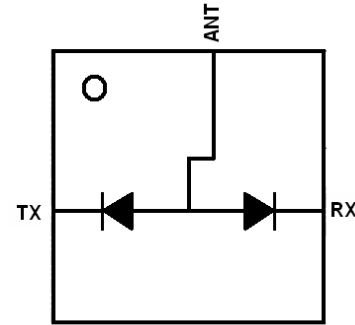
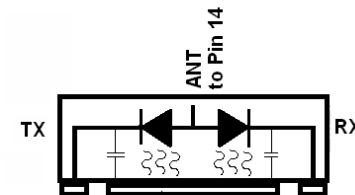

Figure 1.



3mm MLP 16LD



Thermal Ground for Diodes
Electrical ground for internal matching components

Figure 2. Electrical/Thermal Schematic

Figure 3. Sample board layout

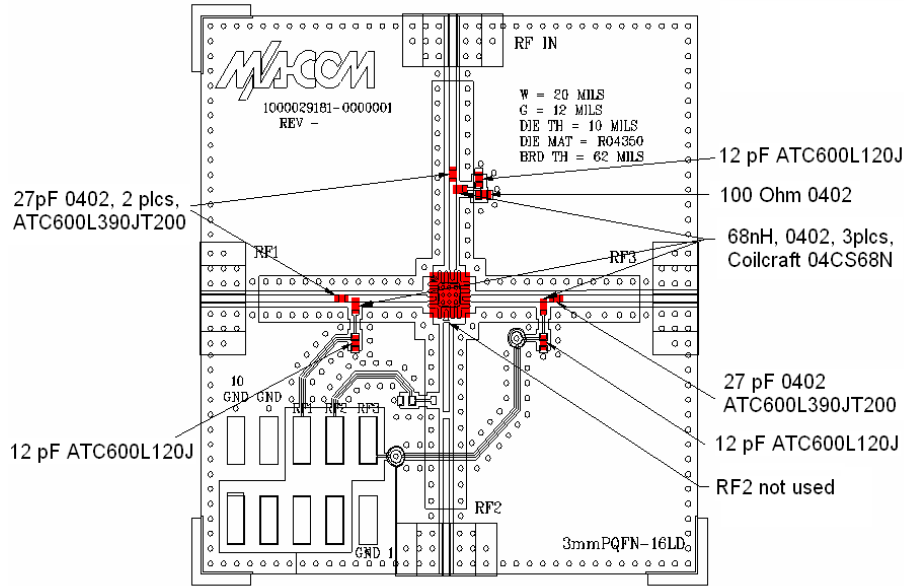

The board was specifically designed for the new series of high power switches and therefore is interchangeable. The component selection and RF ports are specific to part number and operating frequency. In figure 3. the component selection is specific to the MASW-000822-12770T switch and as shown in the drawing the RF2 is cut and not used.

In this case the board is intended to be biased with a negative & positive supply. The schematic in Figure 4. shows the schematic representation of the board and switch. The intention of this board was use the TX and RF ports for the bias paths, however , the device can be biased as any SPDT switch.

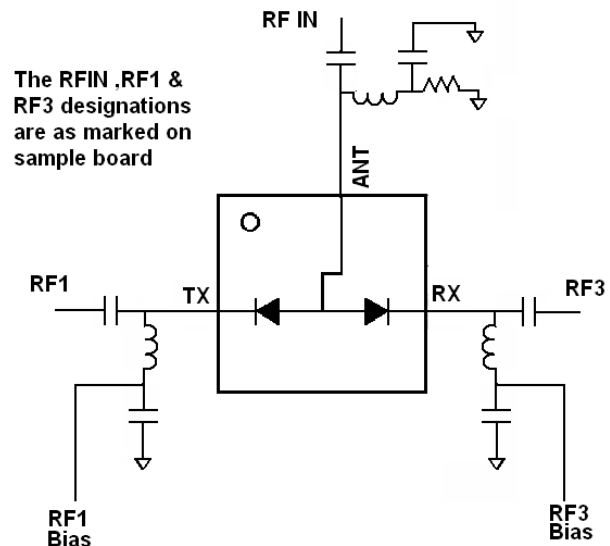
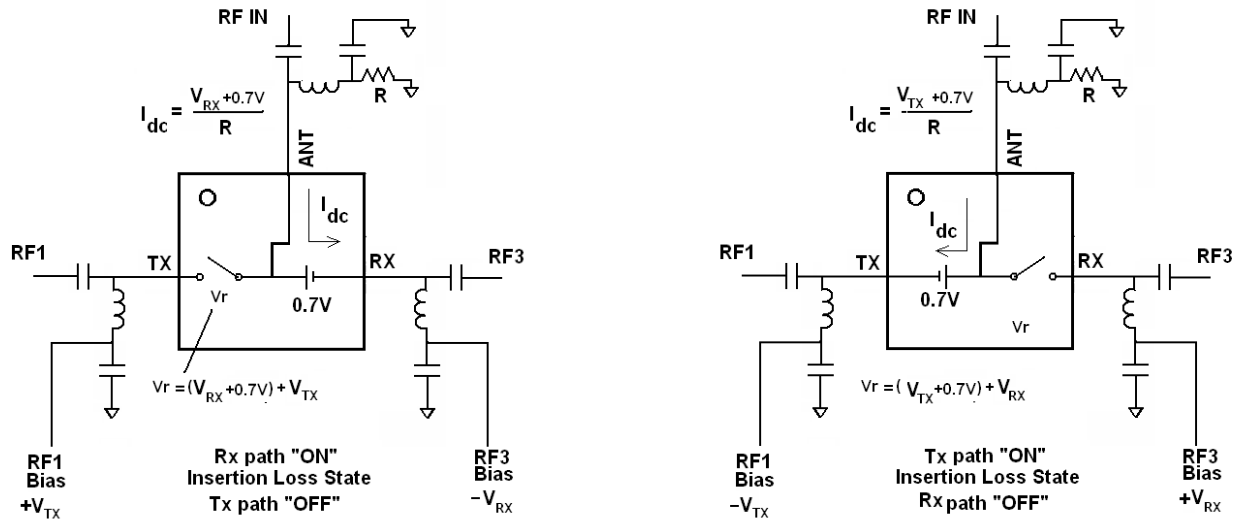

Figure 4. Sample Board Schematic



DC Current	Rx-Antenna RF Condition	Tx-Antenna RF Condition
$I_{DC} = -10$ or -20 mA $V_{r(Tx)}, +40 \geq 0V$	Low Loss	Isolation
$I_{DC} = -10$ or -20 mA $V_{r(Rx)}, +40 \geq 0V$	Isolation	Low Loss
$V_{DC}, +40 \geq 0V$ $V_{r(Tx)} \& V_{r(Rx)}, +40 \geq 0V$	Isolation	Isolation

Figure 5. Dual Positive and Negative Supply Biasing

As mentioned, the sample board supplied accommodates only when there are dual polarity supplies available. The schematic representation shows the biasing required to turn the PIN diodes “ON” and “OFF” for signal transmission and isolation. The truth table shows the reverse bias voltage through the device and current draw for Low Loss and Isolation states of Tx and Rx arms.

In order to accommodate biasing when a single positive supply is available, it is required that bias be available

through the Antenna port. This can be achieved with slight modification of the existing sample board. The 100 ohm resistor would be removed and a “jumper” wire would have to be soldered at the point where the shunt capacitor and bias choke intersect. The schematic representation Figure 6. shows the use of a single positive supply to achieve same results. In order to achieve proper isolation in the “OFF” arm, the back bias (Vr) on the devices should be large enough to sustain higher power levels.

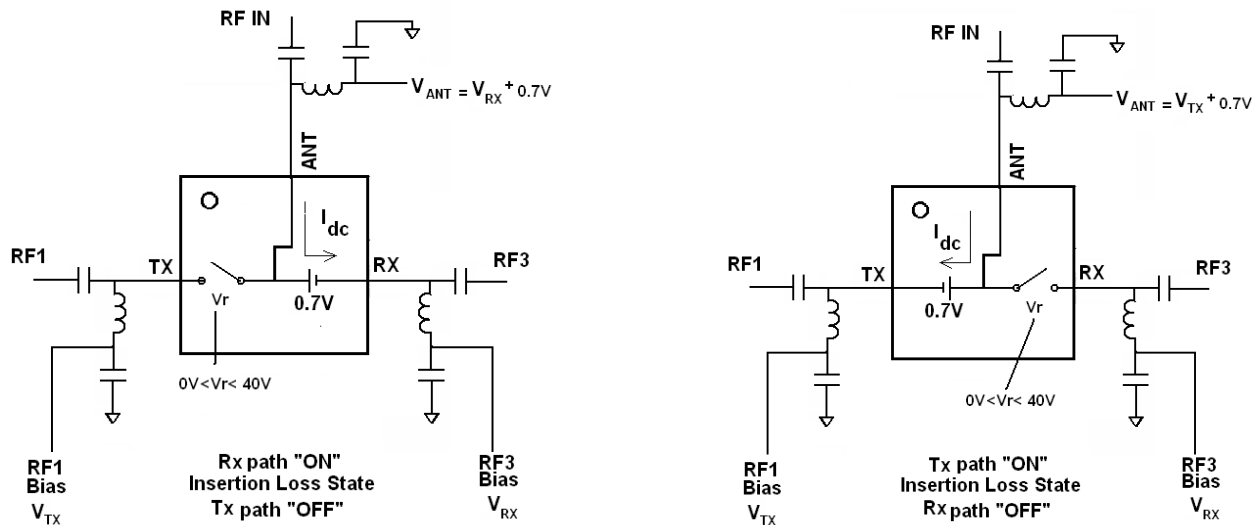

DC Current	Rx-Antenna RF Condition	Tx-Antenna RF Condition
$I_{DC} = -10$ or -20 mA $V_{r(Tx)}, +40 \geq 0V$	Low Loss	Isolation
$I_{DC} = -10$ or -20 mA $V_{r(Rx)}, +40 \geq 0V$	Isolation	Low Loss
$V_{DC}, +40 \geq 0V$ $V_{r(Tx)} \& V_{r(Rx)}, +40 \geq 0V$	Isolation	Isolation

Figure 6. Single Positive Supply Biasing