

High-density Signal Conditioners 10-RACK

4-OUTPUT ISOLATOR

Functions & Features

- Converting a DC input into four isolated standard process signals
- Optional second channel output available at the front terminals and at the Standard Rack connector

Typical Applications

- Isolation between control room and field instrumentation

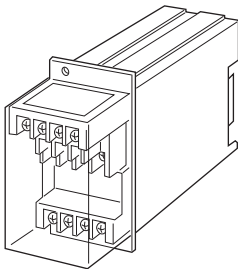

MODEL: 10VS4-[1][2]6[3]6-R[4]

ORDERING INFORMATION

- Code number: 10VS4-[1][2]6[3]6-R[4]
Specify a code from below for each [1] through [4].
(e.g. 10VS4-6A6A6-R/Q)
- Special input range (For code 0)
- Specify the specification for option code /Q
(e.g. /C01)

[1] INPUT

Current

- A: 4 - 20 mA DC (Input resistance 250 Ω)
- D: 0 - 20 mA DC (Input resistance 50 Ω)
- G: 0 - 1 mA DC (Input resistance 1000 Ω)
- H: 10 - 50 mA DC (Input resistance 100 Ω)

Voltage

- 1: 0 - 10 mV DC (Input resistance 10 kΩ min.)
- 2: 0 - 100 mV DC (Input resistance 100 kΩ min.)
- 3: 0 - 1 V DC (Input resistance 1 MΩ min.)
- 4: 0 - 10 V DC (Input resistance 1 MΩ min.)
- 5: 0 - 5 V DC (Input resistance 1 MΩ min.)
- 6: 1 - 5 V DC (Input resistance 1 MΩ min.)
- 0: Specify voltage (See INPUT SPECIFICATIONS)

[2] OUTPUT 1

Current

- A: 4 - 20 mA DC (Load resistance 600 Ω max.)
- B: 2 - 10 mA DC (Load resistance 1200 Ω max.)
- C: 1 - 5 mA DC (Load resistance 2400 Ω max.)
- D: 0 - 20 mA DC (Load resistance 600 Ω max.)
- E: 0 - 16 mA DC (Load resistance 750 Ω max.)
- F: 0 - 10 mA DC (Load resistance 1200 Ω max.)
- G: 0 - 1 mA DC (Load resistance 12 kΩ max.)

Voltage

- 1: 0 - 10 mV DC (Load resistance 10 kΩ min.)
- 2: 0 - 100 mV DC (Load resistance 100 kΩ min.)
- 3: 0 - 1 V DC (Load resistance 100 Ω min.)
- 4: 0 - 10 V DC (Load resistance 1000 Ω min.)
- 5: 0 - 5 V DC (Load resistance 500 Ω min.)
- 6: 1 - 5 V DC (Load resistance 500 Ω min.)

OUTPUT 2

Voltage

- 6: 1 - 5 V DC (Load resistance 5000 Ω min.)

[3] OUTPUT 3

Same range availability as Output 1

OUTPUT 4

- 6: 1 - 5 V DC (Load resistance 5000 Ω min.)

POWER INPUT

DC Power

R: 24 V DC
(Operational voltage range 24 V ±10 %, ripple 10 %p-p max.)

[4] OPTIONS

blank: none
/Q: With options (specify the specification)

SPECIFICATIONS OF OPTION: Q

COATING (For the detail, refer to M-System's web site.)

- /C01: Silicone coating
- /C02: Polyurethane coating
- /C03: Rubber coating

GENERAL SPECIFICATIONS

Construction: Rack-mounted; terminal access via screw terminals at the front and via card-edge connector at the rear; terminal cover provided

Connection

Input: M3.5 screw terminals (torque 0.8 N·m)

Output: Card-edge connector and M3.5 screw terminals
(torque 0.8 N·m)

Power input: Supplied from card-edge connector and M3.5
screw terminals (torque 0.8 N·m)

Screw terminal: Nickel-plated steel

Housing material: Flame-resistant resin (black)

Isolation: Input to output 1 to output 2 to output 3 to output
4 to power

Overrange output: Approx. -10 to +120 % at 1 - 5 V

Zero adjustment: -5 to +5 % (front) (For Output 1 & 2; all 4
outputs are factory calibrated.)

Span adjustment: 95 to 105 % (front) (For Output 1 & 2; all
4 outputs are factory calibrated.)

INPUT SPECIFICATIONS

■ **DC Current:** Input resistor incorporated

■ **DC Voltage:** 0 - 300 V DC

Minimum span: 3 mV

Offset: Max. 1.5 times span

Input span: Input Resistance

3 - 10 mV : $\geq 10 \text{ k}\Omega$

10 - 100 mV : $\geq 10 \text{ k}\Omega$

0.1 - 1 V : $\geq 100 \text{ k}\Omega$

$\geq 1 \text{ V}$: $\geq 500 \text{ k}\Omega$

OUTPUT SPECIFICATIONS

With the input voltage code 3, 4, 5, 6 and current, the
output goes below 0 % when the input is open.

INSTALLATION

Current consumption: Approx. 60 mA with voltage output 1
& 3

Approx. 110 mA with current output 1 & 3

Operating temperature: -5 to +55°C (23 to 131°F)

Operating humidity: 30 to 90 %RH (non-condensing)

Mounting: Standard Rack 10BXx

Weight: 350 g (0.77 lb)

PERFORMANCE in percentage of span

Accuracy: $\pm 0.05 \%$

Temp. coefficient: $\pm 0.015 \%/^{\circ}\text{C}$ ($\pm 0.008 \%/^{\circ}\text{F}$)

Response time: $\leq 0.5 \text{ sec.}$ (0 - 90 %)

Line voltage effect: $\pm 0.1 \%$ over voltage range

Insulation resistance: $\geq 100 \text{ M}\Omega$ with 500 V DC

Dielectric strength: 500 V AC @ 1 minute

(input to output 1 to output 2 to output 3 to output 4 to
power)

1500 V AC @ 1 minute (input or output or power to ground)

EXTERNAL DIMENSIONS & TERMINAL ASSIGNMENTS unit: mm (inch)

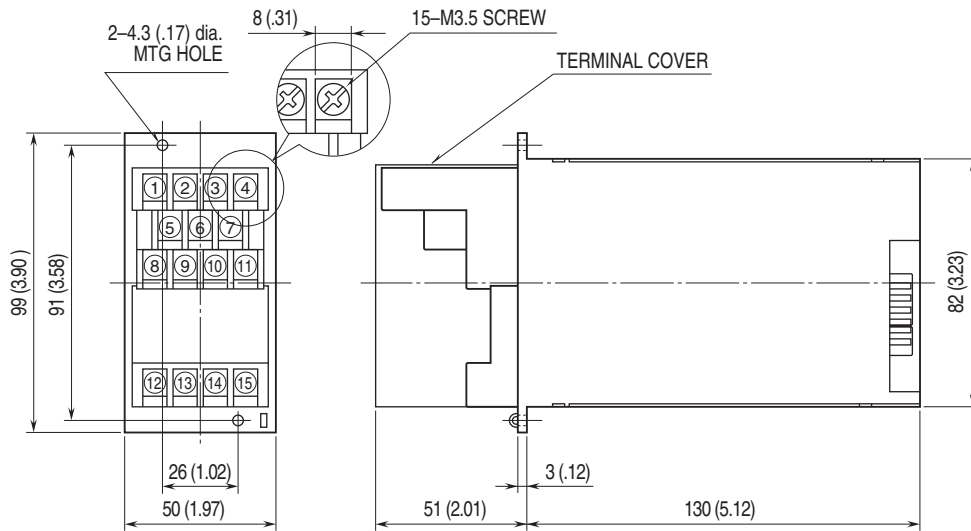

SCHEMATIC CIRCUITRY & CONNECTION DIAGRAM

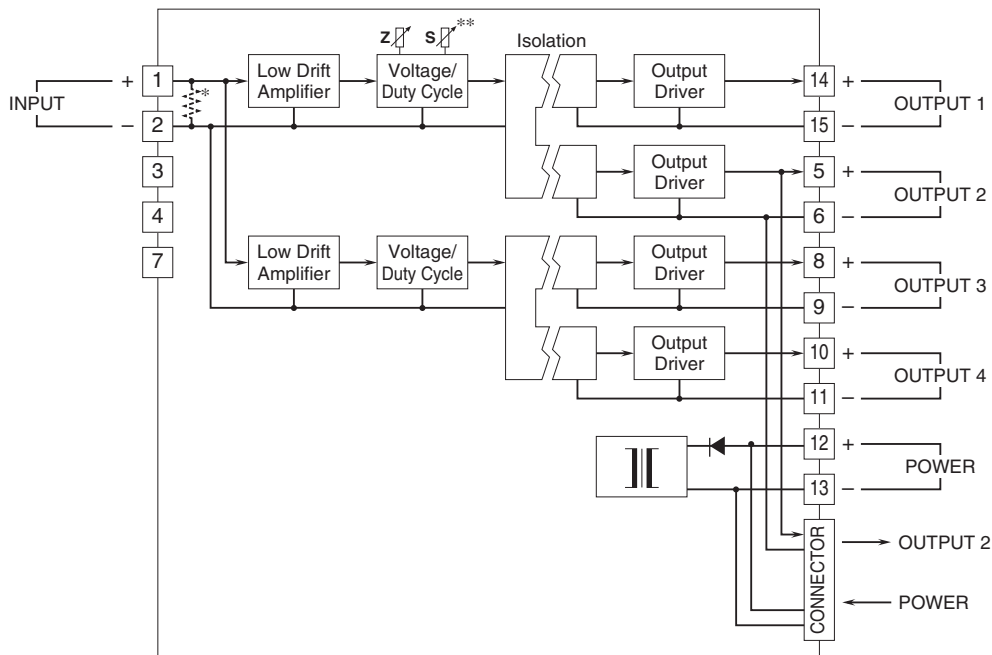

* Input shunt resistor incorporated for current input.
 **Zero and span adjustments affect both Output 1 and Output 2.



Specifications are subject to change without notice.