

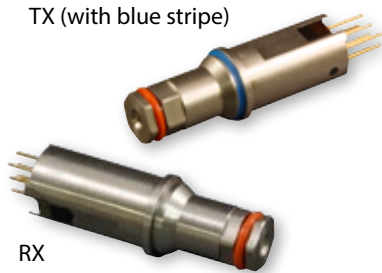

**050-307**  
**Size 8 Cavity Opto-Electronic Contact**  
 2.5mm Terminus, 850nm VCSEL, 100Mbps – 4.25Gbps

**Size 8 cavity opto-electronic ELIO® contact for ARINC 600 connectors**



Size 8 Cavity Opto-electronic contacts transmit and receive differential CML electrical signals over Multimode fiber optic cable. Transmitters consist of a laser driver with a temperature compensation circuit to maintain optical power over the entire operating temperature range, and a 850nm VCSEL laser. Receivers consist of an 850nm PIN Photo Detector, a Transimpedance Amplifier with automatic gain control circuit, and a Limiting Amplifier. Differential output data signals are CML compatible. The transmitter has a Tx Disable pin to turn off transmitter output and a Tx Fault pin to signal a fault condition. Receiver includes a CMOS compatible Loss of Signal Indicator to prevent invalid data.

*Patent Pending*

**KEY FEATURES**

- Front-release, front-insert, front-removable Size #8 OE converter designed for ARINC 600
- ARINC 664, 801, 803, 804, and 818 standard Compliant
- Data rates from 100Mbps to 4.25Gbps
- Supports Fast and Gigabit Ethernet, AFDX, 1x/2x Fibre Channel, DVI, HDMI, SFPDP, Serial Rapid I/O (sRIO).
- 100 ohms differential CML inputs with Tx Fault and Tx Disable
- Link distances up to 550 meters with multimode 50/125µm or 62.5/125 µm fiber
- Single 3.3v power supply
- ELIO® 2.5mm ceramic fiber ferrule
- Mates with ELIO® 2.5mm Termini

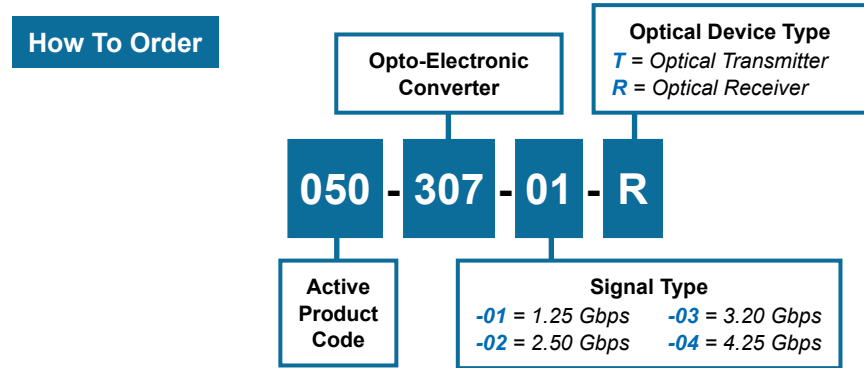

Material/Finish	
Shell	300CRES/Passivate or NM6
Seal	Silicone elastomer
Fiber ferrule & sleeve	Zirconia ceramic
PC tail contacts	Copper alloy/gold plated
PCB flex	FR4 & Polyimide
Solder type	RoHS compliant Sn95/Sb5 (232°C melting temp) & RoHS compliant Sn96.5/Ag3.0/Cu0.5 (217° melting)

**050-307**  
**Size 8 Cavity Opto-Electronic Contact**  
 2.5mm Terminus, 850nm VCSEL, 100Mbps – 4.25Gbps

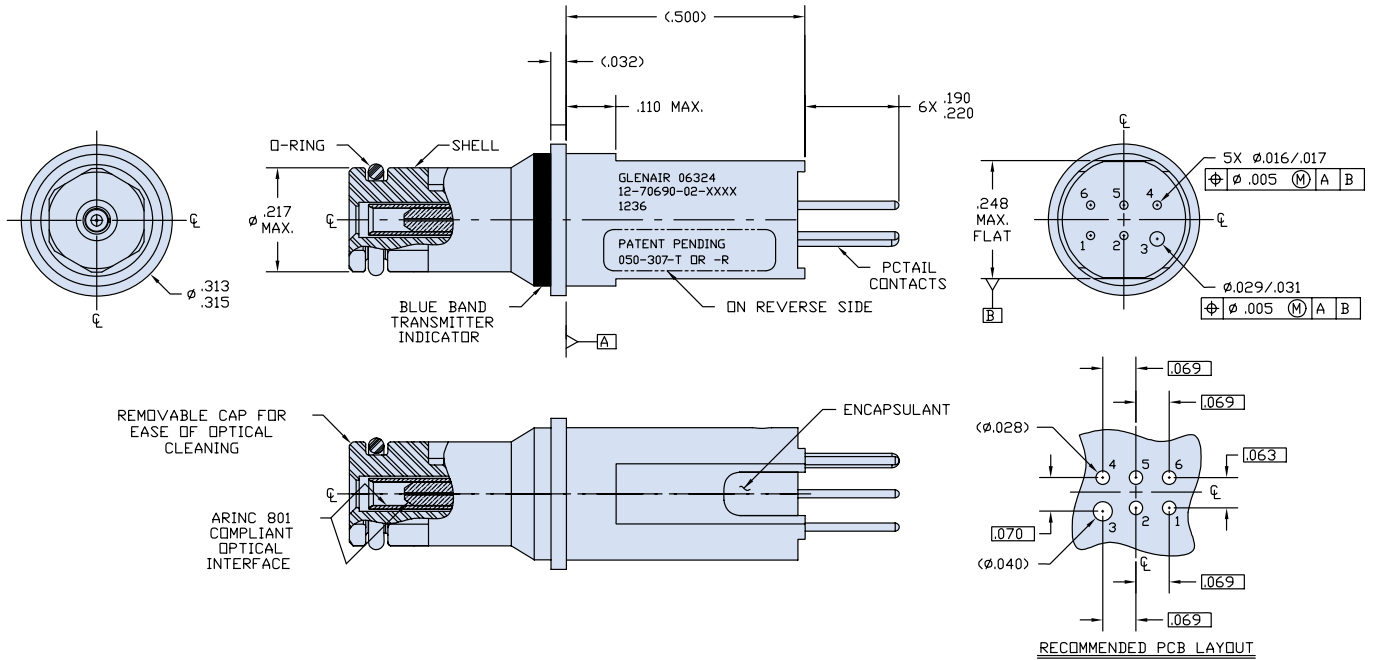

**Component Replacement Part Numbers**

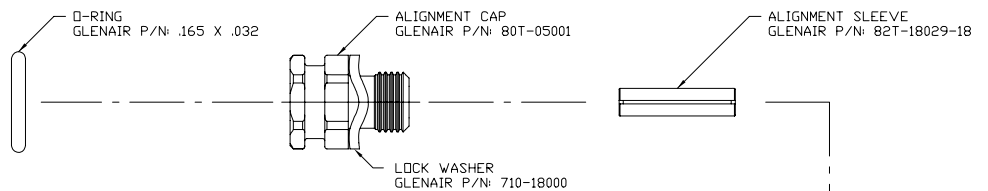

**RECOMMENDED**

**Dry action cleaning tool**



**GCLT - C250**

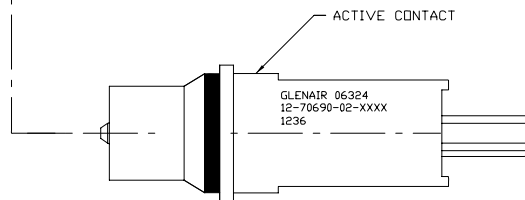

**Notes**

- Contact fits inside Radiall & Souriau ARINC 600 Q11 insert layout - Size 8 Quadrax front release/front removable cavity.
- When installed in ARINC 600 receptacle Q11 insert, this contact couples with ELIO® contact encased in ARINC 600 female Quadrax adapter.
- This contact, when installed in Radiall or Souriau ARINC 600 receptacle with RoHS compliant stand-off will meet applicable optical, mechanical and environmental performance requirements of ARINC 801 contact and ARINC 600 connector.
- Cap may be removed to provide access for fiber tip cleaning, or to replace alignment sleeve.
- Laser safety information: Class 1 21CFR1040.10
- Contact is RoHS compliant.
- Recommended PCB installation soldering contacts can withstand locally applied soldering heating of pins typical RoHS compliant solder temperature of 260°C and typical time of 10 seconds.

## Transmitter

### Recommended Interface Circuit

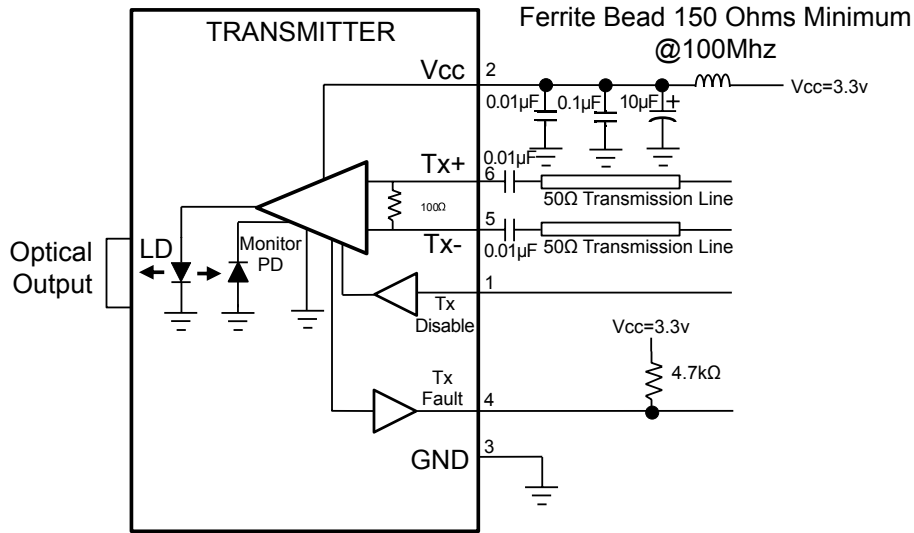

Absolute Max. Rating: Transmitter					
Parameter	Symbol	Min.	Typ.	Max.	Unit
Storage Temperature	T <sub>s</sub>	-55		+100	°C
Supply Voltage	V <sub>cc</sub>	-0.4		+4	V
Tx Disable Input Voltage	V <sub>Disable</sub>	-0.4		V <sub>cc</sub>	V

#### Transmitter Power Supply Current V<sub>cc</sub> = 3.14 to 3.46V

Parameter	Symbol	Min.	Typ.	Max	Unit
Supply Current	I <sub>cc</sub>	50		90	mA

#### Transmitter: Example Optical Link Distances

Protocol	Fiber Type	Distance
Gigabit Ethernet	62.5/125µm, 200MHZ*Km	275 Meters
	50/125µm, 500MHZ*Km	550 Meters

Optical Transmitter					
Parameter	Symbol	Min.	Typ.	Max.	Unit
Optical Output Power	P <sub>out</sub>	-6.5		-1.5	dBm
Optical Wavelength	λ <sub>Out</sub>	830	850	860	nm
Spectral Width	DI <sub>rms</sub>			0.85	nm
Extinction Ratio	E <sub>r</sub>	6.0	10		dB
-01 (1.25 Gbps)					
-02 (2.50 Gbps)					
-03 (3.20 Gbps)					
-04 (4.25 Gbps)					
Total Jitter	T <sub>J</sub>			60	ps

Operating Conditions: Transmitter					
Parameter	Symbol	Min.	Typ.	Max.	Unit
Operating Temperature	T <sub>op</sub>	-40		+85	°C
Supply Voltages	V <sub>cc</sub>	3.14	3.3	3.46	V
Differential Input Voltage	V <sub>id</sub>	250		2200	mVp-p
Power Supply Noise	V <sub>CC</sub> Ripple			0.1	Vp-p

Electrical Pin Arrangement: Transmitter			
Pin	Symbol	Description	Logic
1	TX Disable	Transmit Disable (Input) Logic "1" Input → Disable Transmitter Output	CMOS Internal 4.7KOhm pulldown
2	V <sub>cc</sub>	Power Supply	
3	GND	Signal Ground	
4	TX Fault	Transmitter Fault Indicator (Output) Logic "1" Output → Transmitter Fault Condition	CMOS Open Drain
5	TX-	Transmitter Inverted Data (Input)	CML (Current Mode Logic)
6	TX+	Transmitter Non-Inverted Data (Input)	CML (Current Mode Logic)

Note: 50 µm fiber output

050-307  
**Size 8 Cavity Opto-Electronic Contact**  
 2.5mm Terminus, 850nm VCSEL, 100Mbps – 4.25Gbps



**Receiver**

**Recommended Interface Circuit**

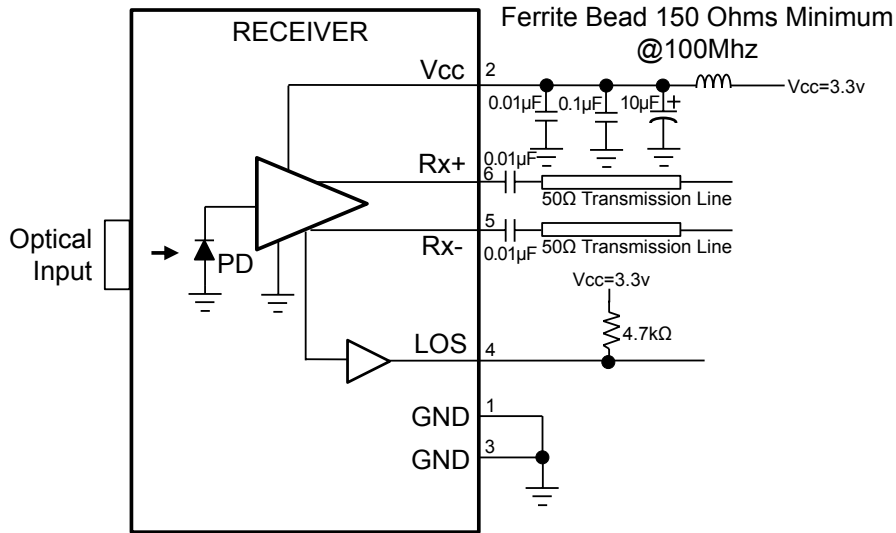

Absolute Max. Rating: Receiver					
Parameter	Symbol	Min.	Typ.	Max.	Unit
Storage Temperature	T <sub>s</sub>	-55		+100	°C
Operating Voltage	V <sub>cc</sub>	-0.4		+4	V

Operating Conditions: Receiver					
Parameter	Symbol	Min.	Typ.	Max.	Unit
Operating Temperature	T <sub>op</sub>	-40		+85	°C
Supply Voltages	V <sub>cc</sub>	3.14	3.3	3.46	V
Power Supply Noise	V <sub>CC</sub> Ripple			0.15	V

Receiver Power Supply Current V <sub>cc</sub> = 3.14 to 3.46V, Over Top					
Parameter	Symbol	Min.	Typ.	Max.	Unit
Supply Current	I <sub>cc</sub>			90	mA

Optical Receiver					
Parameter	Symbol	Min.	Typ.	Max.	Unit
Optical Sensitivity 125 Mbps-1.25 Gbps ER=9dB, PRBS 2 <sup>7</sup> -1 BER=10 <sup>-12</sup>		-17			dBm
-01 = 125 Mbps		-17			dBm
-01 = 1.25 Gbps		-17			dBm
-02 = 2.50 Gbps		-15			dBm
-03 = 3.20 Gbps		-15			dBm
-04 = 4.25 Gbps		-14			dBm
Optical Overload				0	dBm
Optical Wavelength	λ <sub>out</sub>	830		860	nm
Differential Output Swing (P-P)	V <sub>d</sub> diff	600		1200	mV
LOS Assert Level	LOS <sub>h</sub>		-24	-22	dBm
LOS Hysteresis	LOS <sub>HYS</sub>	1.5	2.3		dB

Electrical Pin Arrangement - Receiver			
Pin	Symbol	Description	Logic
1	GND	Signal Ground	
2	V <sub>cc</sub>	Power Supply	
3	GND	Signal Ground	
4	LOS	Loss of Signal (Output) Loss of Valid Optical Signal → Logic "1" Output	CMOS Open Drain
5	RX-	Receiver Inverted Data (Output)	CML (Current Mode Logic)
6	RX+	Receiver Non-Inverter Data (Output)	CML (Current Mode Logic)

Note: 62.5 µm fiber input