

27MHz Multiple output XO with Audio Clock

FEATURES

- 2 XO outputs at 27MHz (27MHz crystal input).
- Selectable Audio Clocks supporting:
 - 32kHz, 44.1kHz, 48kHz, 64kHz and 96kHz sampling rates
 - 256, 384 and 512 oversampling ratios
 - 8.192, 11.2896, 12.288, 16.9344, 16.384, 18.432, 22.5792, 24.576MHz audio frequencies
- On-the-fly switching of the audio frequency
- Power down tri-state selector.
- 3.3V Operating Voltage.
- Available in 16-Pin SSOP

PACKAGE PIN CONFIGURATION

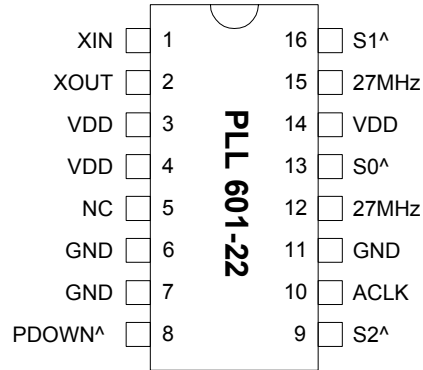

XIN = 27 MHz

Note: ^: Internal pull-up resistor. The internal pull-up resistor results in a default high value when no pull-down resistor is connected to this pin.

DESCRIPTION

The PLL601-22 is a low cost integrated XO IC with power down feature, designed to work with a fundamental 27MHz crystal to provide the most common audio clocks (8.192, 11.2896, 12.288, 16.9344, 16.384, 18.432, 22.5792, and 24.576MHz) required by sampling rates of 32kHz, 44.1kHz, 48kHz, 64kHz and 96kHz (256, 384 and 512 oversampling ratios). The wide range of audio frequencies makes it ideal for STB and MPEG Video applications.

AUDIO CLOCK SELECTION

S2	S1	S0	ACLK (MHz)
0	0	0	8.192
0	0	1	11.2896
0	1	0	12.288
0	1	1	16.9344
1	0	0	18.432
1	0	1	16.384
1	1	0	22.5792
1	1	1	24.576

BLOCK DIAGRAM

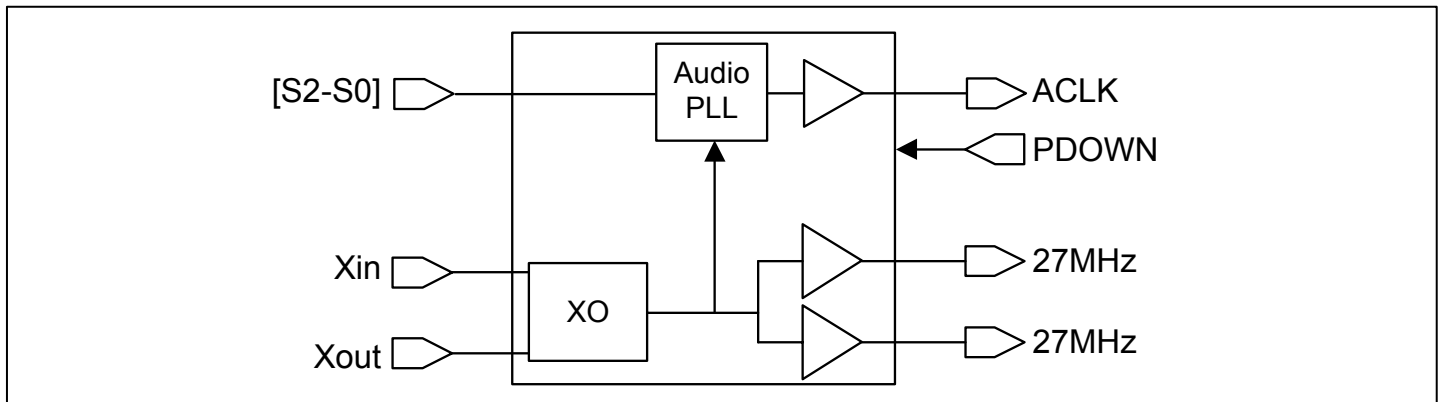

27MHz Multiple output XO with Audio Clock
PIN DESCRIPTIONS

Name	Pin #	Type	Description
XIN	1	I	Crystal input to be connected to fundamental parallel mode crystal. ($C_L=14.5\text{pF}$).
XOUT	2	I	Crystal output connector.
VDD	3	P	3.3V power supply.
VDD	4	P	3.3V power supply.
NC	5	I	Not Connected.
GND	6	P	Ground.
GND	7	P	Ground.
PDOWN	8	I	Digital control input. This input powers down the entire chip and tri-states all outputs when low. $60\text{k}\Omega$ internal pull-up.
S2	9	I	Digital control input to select audio frequency. $60\text{k}\Omega$ internal pull-up.
ACLK	10	O	Audio clock output (see selection table on page 1).
GND	11	P	Ground.
27MHz	12	O	27MHz XO output.
S0	13	I	Digital control input to select audio frequency. $60\text{k}\Omega$ internal pull-up.
VDD	14	P	3.3V power supply.
27MHz	15	O	27MHz XO output.
S1	16	I	Digital control input to select audio frequency. $60\text{k}\Omega$ internal pull-up.

Notes: I – input pin; P – power supply/ground pin; O – output pin.

ELECTRICAL SPECIFICATIONS
1. Absolute Maximum Ratings

PARAMETERS	SYMBOL	MIN.	MAX.	UNITS
Supply Voltage	V_{DD}		4.6	V
Input Voltage, dc	V_I	-0.5	$V_{DD}+0.5$	V
Output Voltage, dc	V_O	-0.5	$V_{DD}+0.5$	V
Storage Temperature	T_S	-65	150	$^{\circ}\text{C}$
Ambient Operating Temperature*	T_A	-40	85	$^{\circ}\text{C}$
Junction Temperature	T_J		125	$^{\circ}\text{C}$
Lead Temperature (soldering, 10s)			260	$^{\circ}\text{C}$
ESD Protection, Human Body Model			2	kV

Exposure of the device under conditions beyond the limits specified by Maximum Ratings for extended periods may cause permanent damage to the device and affect product reliability. These conditions represent a stress rating only, and functional operations of the device at these or any other conditions above the operational limits noted in this specification is not implied.

* **Note:** Operating Temperature is guaranteed by design for all parts (COMMERCIAL and INDUSTRIAL), but tested for COMMERCIAL grade only.

27MHz Multiple output XO with Audio Clock
2. Crystal Specifications

PARAMETERS	SYMBOL	CONDITIONS	MIN.	TYP.	MAX.	UNITS
Crystal Resonator Frequency	F_{XIN}	Parallel Fundamental Mode		27		MHz
Crystal Loading Rating	$C_{L(xtal)}$			14.5		pF
Recommended ESR	R_E	AT cut			30	Ω

3. General Electrical Specifications

PARAMETERS	SYMBOL	CONDITIONS	MIN.	TYP.	MAX.	UNITS
Supply Current, Dynamic (with Loaded Outputs)	I_{DD}	15pF Load		20	30	mA
Operating Voltage	V_{DD}		2.97	3.30	3.63	V

4. AC Electrical Specifications

PARAMETERS	SYMBOL	CONDITIONS	MIN.	TYP.	MAX.	UNITS
Input Crystal Frequency				27		MHz
Output Clock Rise Time		0.8V ~ 2.0V with 10 pF load			1.5	ns
		0.3V ~ 3.0V with 15 pF load		2.5	4	
Output Clock Fall Time		2.0V ~ 0.8V with 10 pF load			1.5	
		3.0V ~ 0.3V with 15pF load		2	3	
Output Clock Duty Cycle		50% V_{DD}	45	50	55	%
Short Circuit Current				± 50		mA

5. Jitter specifications

PARAMETERS	CONDITIONS	FREQUENCY	MIN.	TYP.	MAX.	UNITS
Cycle to Cycle Jitter	$T_{cyc-cyc}$	27MHz		100		ps
Cycle to Cycle Jitter	$T_{cyc-cyc}$	Audio Clock		150		ps

27MHz Multiple output XO with Audio Clock

PACKAGE INFORMATION

16 PIN SSOP (inch)			
Symbol	Min.	Nom.	Max.
A	.053	.064	.069
A1	.004	.006	.010
B	.008	-	.012
C	.007	-	.010
D	.189	.193	.197
E	.150	.154	.157
H	.228	.236	.244
L	.016	.025	.050
e	.025 BASIC		

ORDERING INFORMATION

For part ordering, please contact our Sales Department:
47745 Fremont Blvd., Fremont, CA 94538, USA
Tel: (510) 492-0990 Fax: (510) 492-0991

PART NUMBER

The order number for this device is a combination of the following:
Device number, Package type and Operating temperature range

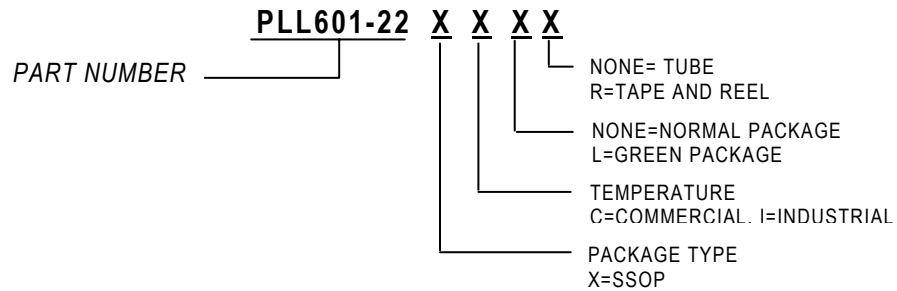

Order Number	Marking	Package Option
PLL601-22XC	P601-22XC	16-pin SSOP - Tube
PLL601-22XC-R	P601-22XC	16-pin SSOP - Tape and Reel
PLL601-22XCL	P601-22XCL	16-pin SSOP - Tube
PLL601-22XCL-R	P601-22XCL	16-pin SSOP - Tape and Reel

PhaseLink Corporation, reserves the right to make changes in its products or specifications, or both at any time without notice. The information furnished by Phaselink is believed to be accurate and reliable. However, PhaseLink makes no guarantee or warranty concerning the accuracy of said information and shall not be responsible for any loss or damage of whatever nature resulting from the use of, or reliance upon this product.

LIFE SUPPORT POLICY: PhaseLink's products are not authorized for use as critical components in life support devices or systems without the express written approval of the President of PhaseLink Corporation.