

RoHS

SPECIFICATIONS

Rated Current: 3.0AMP
 Contact Resistance: 20mΩ Max
 Withstand Voltage: 1000V AC/DC
 Insulation Resistance: 1000MΩ Min
 Operation Temperature: -40°C to +105°C
 Contact Material: Brass
 Contact Plating: Au Over Ni
 Insulator Material: Polyester (UL94V-0)
 Standard: PA6T
 Max. Processing Temp: 230°C for 30-60 seconds
 (260°C for 10 seconds)

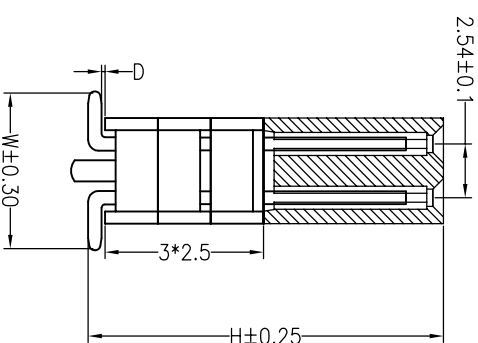
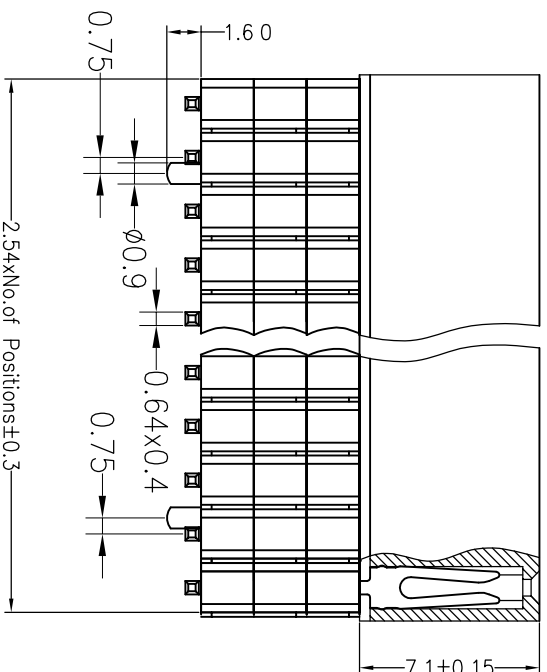
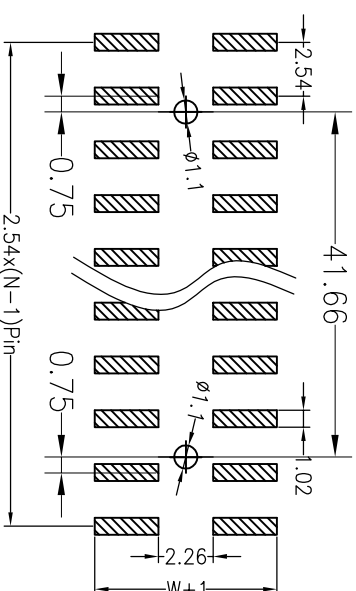
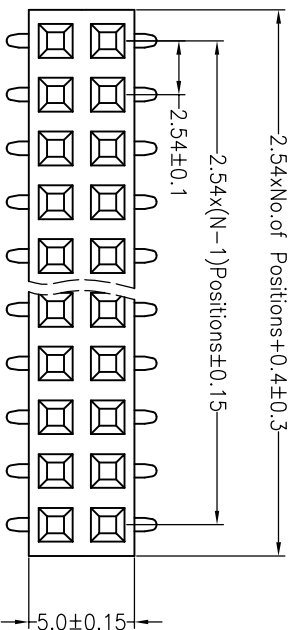

Dimension antitheses list				
ITEM	H	D	W	
Alternate	15.00	0	8.20	

深圳市连盛精密连接器有限公司

PART NO. FH-00205---A0001

TITLE: 2.54FH H7.1mm+3H2.5mm 2x20pin SMT W5.0mm 带偏柱 偏移0.75 直径0.9 高1.6

OPERATION		DRAW		SCALE		FIT	
X.X	±0.30			UNIT	mm		
X.XX	±0.20	CHECK		SIZE	A4		
X.XXX	±0.10			SHEET	1/1		
Angle	±3°	APPROVE		PROJ.	◆		
DIM	TOL						

REV	DATE	MODIFICATION DESCRIPTION	CHANGE
A0	2012.10.08	NEW DRAWING	
1			