

**PLEASE CHECK WWW.MOLEX.COM FOR LATEST PART INFORMATION**

**Part Number:** [0702871289](#)  
**Status:** **Active**  
**Description:** 2.54mm (.100") Pitch C-Grid® Header, Breakaway, Dual Row, Vertical, with Retention Pin, 92 Circuits, 8.13mm (.320") Mating Pin Length, 0.76µm (30µ") Gold (Au) Selective Plating

**Documents:**

<a href="#">3D Model</a>	<a href="#">Product Specification PS-70280 (PDF)</a>
<a href="#">Packaging Specification (PDF)</a>	<a href="#">RoHS Certificate of Compliance (PDF)</a>
<a href="#">Drawing (PDF)</a>	

**General**

Product Family	PCB Headers
Series	<a href="#">70287</a>
Application	Board-to-Board, Wire-to-Board
Product Name	C-Grid®

**Physical**

Breakaway	Yes
Circuits (Loaded)	92
Circuits (maximum)	92
Color - Resin	Black
Durability (mating cycles max)	25
First Mate / Last Break	No
Glow-Wire Compliant	No
Guide to Mating Part	No
Keying to Mating Part	N/A
Lock to Mating Part	None
Material - Metal	Brass
Material - Plating Mating	Gold
Material - Plating Termination	Tin
Material - Resin	High Temperature Thermoplastic
Number of Rows	2
Orientation	Vertical
PC Tail Length (in)	0.125 In
PC Tail Length (mm)	3.18 mm
PCB Locator	No
PCB Retention	None
PCB Thickness Recommended (in)	0.062 In
PCB Thickness Recommended (mm)	1.57 mm
Packaging Type	Bag
Pitch - Mating Interface (in)	0.100 In
Pitch - Mating Interface (mm)	2.54 mm
Pitch - Term. Interface (in)	0.100 In
Pitch - Term. Interface (mm)	2.54 mm
Plating min: Mating (µin)	32.000
Plating min: Mating (µm)	0.80
Plating min: Termination (µin)	80.000
Plating min: Termination (µm)	2.00
Polarized to Mating Part	No
Polarized to PCB	No
Shrouded	No
Stackable	Yes
Surface Mount Compatible (SMC)	Yes
Temperature Range - Operating	-40°C to +120°C
Termination Interface: Style	Through Hole

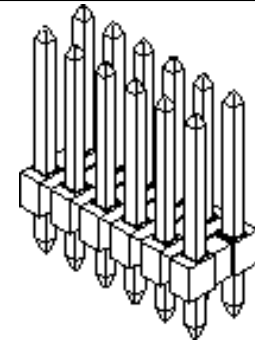

*Series  
image - Reference only*

**EU RoHS**

**ELV and RoHS  
Compliant**  
**REACH SVHC  
Contains SVHC: No**  
**Halogen-Free  
Status  
Not Reviewed**

**China RoHS**



**Need more information on product  
environmental compliance?**

Email [productcompliance@molex.com](mailto:productcompliance@molex.com)  
 For a multiple part number RoHS Certificate of Compliance, [click here](#)

Please visit the [Contact Us](#) section for any non-product compliance questions.

**Search Parts in this Series**

[70287Series](#)

**Mates With**

7859 Shunt, C-Grid Receptacles, SL™  
 Crimp, FFC and IDT Housing

**Electrical**

Current - Maximum per Contact	3A
Voltage - Maximum	250V DC

**Solder Process Data**

Duration at Max. Process Temperature (seconds)	5
Lead-free Process Capability	Wave Capable (TH only)
Max. Cycles at Max. Process Temperature	1
Process Temperature max. C	260

**Material Info****Reference - Drawing Numbers**

Product Specification	PS-70280
Sales Drawing	SD-70287-003

This document was generated on 04/01/2010

**PLEASE CHECK [WWW.MOLEX.COM](http://WWW.MOLEX.COM) FOR LATEST PART INFORMATION**

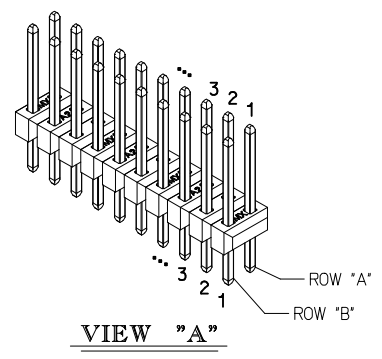
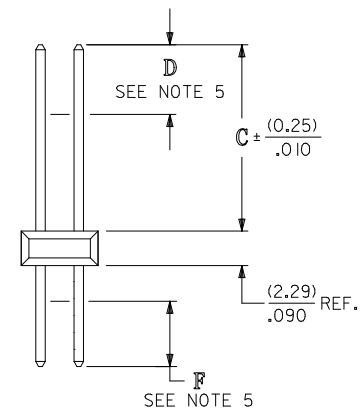
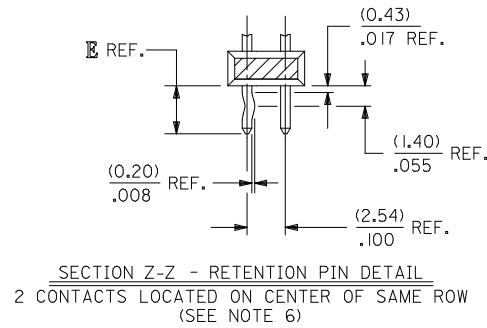
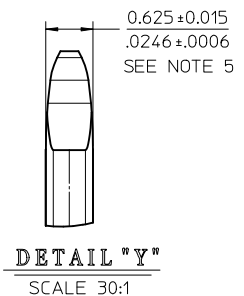
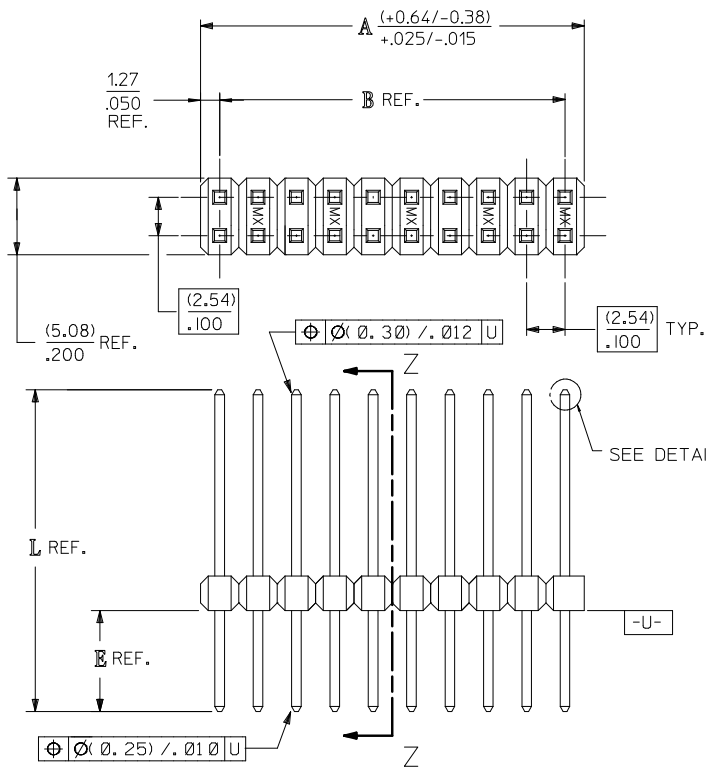

- NOTES:**
- MATERIAL: WAFER - GLASS FILLED LIQUID CRYSTAL POLYMER, UL94V-0, COLOR: BLACK  
PIN - COPPER ALLOY
  - FINISH: (TIN) OVERALL TIN: (0.00381)/.000150 MIN., OVERALL NICKEL UNDERPLATE: (0.00127)/.000050 MIN.  
(15 GOLD) SELECT GOLD: (0.00038)/.000015 MIN., SELECT TIN: (0.00191)/.000075 MIN., OVERALL NICKEL UNDERPLATE: (0.00127)/.000050 MIN.  
(30 GOLD) SELECT GOLD: (0.00076)/.000030 MIN., SELECT TIN: (0.00191)/.000075 MIN., OVERALL NICKEL UNDERPLATE: (0.00127)/.000050 MIN.
  - PRODUCT SPECIFICATION: PS-70280
  - PACKAGING INFORMATION: (UNLESS OTHERWISE NOTED IN TABLES)  
PARTS TO BE PACKAGED PER PK-70873-0353.
  - MEASURE POINT FOR PLATING THICKNESS. DIMENSION D IS ALSO THE MEASURE POINT FOR PIN WIDTH.
  - RETENTIVE TAIL LOCATIONS (SEE VIEW "A")

NUMBER OF CIRCUITS IN ROW B	RETENTIVE TAIL LOCATIONS
EVEN NUMBER	2 PINS IN THE MIDDLE OF ROW B
ODD NUMBER	PIN IN THE CENTER OF ROW B AND ONE OTHER PIN IN ROW B ON EITHER SIDE OF THE CENTER PIN

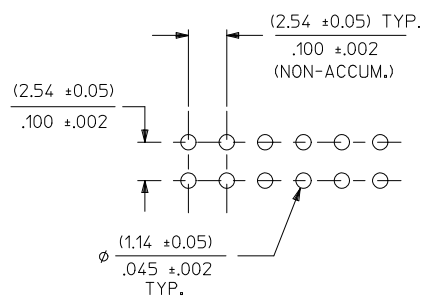

CKT. SIZE	DIM. A REF.		DIM. B REF.	
	(MM)	INCH	(MM)	INCH
4	(5.08)	.200	(2.54)	.100
6	(7.62)	.300	(5.08)	.200
8	(10.16)	.400	(7.62)	.300
10	(12.70)	.500	(10.16)	.400
12	(15.24)	.600	(12.70)	.500
14	(17.78)	.700	(15.24)	.600
16	(20.32)	.800	(17.78)	.700
18	(22.86)	.900	(20.32)	.800
20	(25.40)	1.000	(22.86)	.900
22	(27.94)	1.100	(25.40)	1.000
24	(30.48)	1.200	(27.94)	1.100
26	(33.02)	1.300	(30.48)	1.200
28	(35.56)	1.400	(33.02)	1.300
30	(38.10)	1.500	(35.56)	1.400
32	(40.64)	1.600	(38.10)	1.500
34	(43.18)	1.700	(40.64)	1.600
36	(45.72)	1.800	(43.18)	1.700
38	(48.26)	1.900	(45.72)	1.800
40	(50.80)	2.000	(48.26)	1.900
42	(53.34)	2.100	(50.80)	2.000
44	(55.88)	2.200	(53.34)	2.100
46	(58.42)	2.300	(55.88)	2.200
48	(60.96)	2.400	(58.42)	2.300
50	(63.50)	2.500	(60.96)	2.400
52	(66.04)	2.600	(63.50)	2.500
54	(68.58)	2.700	(66.04)	2.600
56	(71.12)	2.800	(68.58)	2.700
58	(73.66)	2.900	(71.12)	2.800
60	(76.20)	3.000	(73.66)	2.900
62	(78.74)	3.100	(76.20)	3.000
64	(81.28)	3.200	(78.74)	3.100
66	(83.82)	3.300	(81.28)	3.200
68	(86.36)	3.400	(83.82)	3.300
70	(88.90)	3.500	(86.36)	3.400
72	(91.44)	3.600	(88.90)	3.500
74	(93.98)	3.700	(91.44)	3.600
76	(96.52)	3.800	(93.98)	3.700
78	(99.06)	3.900	(96.52)	3.800
80	(101.60)	4.000	(99.06)	3.900
82	(104.14)	4.100	(101.60)	4.000
84	(106.68)	4.200	(104.14)	4.100
86	(109.22)	4.300	(106.68)	4.200
88	(111.76)	4.400	(109.22)	4.300
90	(114.30)	4.500	(111.76)	4.400
92	(116.84)	4.600	(114.30)	4.500
94	(119.38)	4.700	(116.84)	4.600
96	(121.92)	4.800	(119.38)	4.700
98	(124.46)	4.900	(121.92)	4.800
100	(127.00)	5.000	(124.46)	4.900

- PIN PUSHOUT FORCE: 3 LBS. MIN. (IN EITHER DIRECTION)
- FOR ILLUSTRATION PURPOSES, 20 (DUAL 10) CIRCUIT SIZE IS SHOWN.
- PINS MUST MEET SOLDERABILITY SPEC. SMES-152, EXCEPT VOIDS ARE PERMISSIBLE AT BANDOLIER PIN FAYING SURFACE. (APPROXIMATELY (0.64)/.025 LNG X (0.15)/.006 WIDE AT 2 LOCATIONS)
- PARTS CONFORM TO CLASS B REQUIREMENTS OF COSMETIC SPECIFICATION PS-45499-002.

PARTS LISTED ON THIS DRAWING REPLACE PARTS LISTED ON DRAWING SDA-70287-0001-5000 WHICH WILL BECOME OBSOLETE.

REMOVE PART #S EC NO: UCP2010-0011 DRAWN: KIPPER 2010/02/12 CHKD: BELLE 2010/02/15 APPR: FSMITH 2010/03/02	QUALITY SYMBOLS ▽=0 ▽=0	GENERAL TOLERANCES (UNLESS SPECIFIED) <table border="1"> <tr><th>mm</th><th>INCH</th></tr> <tr><td>4 PLACES ± ---</td><td>± ---</td></tr> <tr><td>3 PLACES ± ---</td><td>± .005</td></tr> <tr><td>2 PLACES ± 0.13</td><td>± .01</td></tr> <tr><td>1 PLACE ± 0.25</td><td>± ---</td></tr> </table>	mm	INCH	4 PLACES ± ---	± ---	3 PLACES ± ---	± .005	2 PLACES ± 0.13	± .01	1 PLACE ± 0.25	± ---	DIMENSION STYLE <b>MM/IN</b>	SCALE <b>1:1</b>	DESIGN UNITS <b>INCH</b>	THIRD ANGLE PROJECTION
	mm	INCH														
4 PLACES ± ---	± ---															
3 PLACES ± ---	± .005															
2 PLACES ± 0.13	± .01															
1 PLACE ± 0.25	± ---															
SHT. REV. B1	DRAFT WHERE APPLICABLE MUST REMAIN WITHIN DIMENSIONS	MATERIAL NO. <b>SEE CHART</b>	DRAWN BY ADERR	DATE 2006/09/01	CHECKED BY LSCMHMTD	DATE 2006/09/01										

APPROVED BY  
FSMITH  
DATE  
2006/09/05

MOLEX MOLEX INCORPORATED

DOCUMENT NO.  
SD-70287-003

SHEET NO.  
1 OF \*

THIS DRAWING CONTAINS INFORMATION THAT IS PROPRIETARY TO MOLEX INCORPORATED AND SHOULD NOT BE USED WITHOUT WRITTEN PERMISSION

ENG. NO: A-70287-1049 / 1097			
DIM. C		(8.13) / .320	
DIM. E (REF.)		(3.18) / .125	
DIM. L (REF.)		(13.59) / .535	
MATING SIDE PLATING		TIN	
DIM. D (MEASURE PT.)		(4.57) / .180	
P.C. BOARD SIDE PLATING		TIN	
DIM. F (MEASURE PT.)		(1.27) / .050	
RETENTIVE PIN LOCATION		SEE NOTE 6, SHEET 1	
PACKAGING		BULK - PK-70873-0353	
CKTS	MATERIAL NUMBER	CKTS	MATERIAL NUMBER
04	70287-1049	54	70287-1074
06	70287-1050	56	70287-1075
08	70287-1051	58	70287-1076
10	70287-1052	60	70287-1077
12	70287-1053	62	70287-1078
14	70287-1054	64	70287-1079
16	70287-1055	66	70287-1080
18	70287-1056	68	70287-1081
20	70287-1057	70	70287-1082
22	70287-1058	72	70287-1083
24	70287-1059	74	70287-1084
26	70287-1060	76	70287-1085
28	70287-1061	78	70287-1086
30	70287-1062	80	70287-1087
32	70287-1063	82	70287-1088
34	70287-1064	84	70287-1089
36	70287-1065	86	70287-1090
38	70287-1066	88	70287-1091
40	70287-1067	90	70287-1092
42	70287-1068	92	70287-1093
44	70287-1069	94	70287-1094
46	70287-1070	96	70287-1095
48	70287-1071	98	70287-1096
50	70287-1072	100	70287-1097
52	70287-1073		

ENG. NO: A-70287-1147 / 1195			
DIM. C		(8.13) / .320	
DIM. E (REF.)		(3.18) / .125	
DIM. L (REF.)		(13.59) / .535	
MATING SIDE PLATING		15 GOLD	
DIM. D (MEASURE PT.)		(4.57) / .180	
P.C. BOARD SIDE PLATING		TIN	
DIM. F (MEASURE PT.)		(1.27) / .050	
RETENTIVE PIN LOCATION		SEE NOTE 6, SHEET 1	
PACKAGING		BULK - PK-70873-0353	
CKTS	MATERIAL NUMBER	CKTS	MATERIAL NUMBER
04	70287-1147	54	70287-1172
06	70287-1148	56	70287-1173
08	70287-1149	58	70287-1174
10	70287-1150	60	70287-1175
12	70287-1151	62	70287-1176
14	70287-1152	64	70287-1177
16	70287-1153	66	70287-1178
18	70287-1154	68	70287-1179
20	70287-1155	70	70287-1180
22	70287-1156	72	70287-1181
24	70287-1157	74	70287-1182
26	70287-1158	76	70287-1183
28	70287-1159	78	70287-1184
30	70287-1160	80	70287-1185
32	70287-1161	82	70287-1186
34	70287-1162	84	70287-1187
36	70287-1163	86	70287-1188
38	70287-1164	88	70287-1189
40	70287-1165	90	70287-1190
42	70287-1166	92	70287-1191
44	70287-1167	94	70287-1192
46	70287-1168	96	70287-1193
48	70287-1169	98	70287-1194
50	70287-1170	100	70287-1195
52	70287-1171		

<b>B1</b>	REV: ECR/ECN INFORMATION	TITLE: SALES ASS'Y – HIGH TEMP. DUAL ROW, .025" SQ PINS .100" GRID W/ RET. PINS	SHEET No.  <b>- 2 -</b>
	EC No: UCP2010-0011		
	DATE: 3/2/2010		
DOCUMENT NUMBER: <b>SD-70287-003</b>	CREATED / REVISED BY: <b>MKIPPER</b>	CHECKED BY: <b>JBELL</b>	APPROVED BY: <b>FSMITH</b>

ENG. NO: A-70287-1245 / 1293

DIM. C		(8.13) / .320	
DIM. E (REF.)		(3.18) / .125	
DIM. L (REF.)		(13.59) / .535	
MATING SIDE PLATING		30 GOLD	
DIM. D (MEASURE PT.)		(4.57) / .180	
P.C. BOARD SIDE PLATING		TIN	
DIM. F (MEASURE PT.)		(1.27) / .050	
RETENTIVE PIN LOCATION		SEE NOTE 6, SHEET 1	
PACKAGING		BULK - PK-70873-0353	
CKTS	MATERIAL NUMBER	CKTS	MATERIAL NUMBER
04	70287-1245	54	70287-1270
06	70287-1246	56	70287-1271
08	70287-1247	58	70287-1272
10	70287-1248	60	70287-1273
12	70287-1249	62	70287-1274
14	70287-1250	64	70287-1275
16	70287-1251	66	70287-1276
18	70287-1252	68	70287-1277
20	70287-1253	70	70287-1278
22	70287-1254	72	70287-1279
24	70287-1255	74	70287-1280
26	70287-1256	76	70287-1281
28	70287-1257	78	70287-1282
30	70287-1258	80	70287-1283
32	70287-1259	82	70287-1284
34	70287-1260	84	70287-1285
36	70287-1261	86	70287-1286
38	70287-1262	88	70287-1287
40	70287-1263	90	70287-1288
42	70287-1264	92	70287-1289
44	70287-1265	94	70287-1290
46	70287-1266	96	70287-1291
48	70287-1267	98	70287-1292
50	70287-1268	100	70287-1293
52	70287-1269		

<b>B1</b>	REV:	ECR/ECN INFORMATION	TITLE:	SALES ASS'Y – HIGH TEMP. DUAL ROW, .025" SQ PINS .100" GRID W/ RET. PINS	SHEET No.
		EC No: <b>UCP2010-0011</b>			<b>- 3 -</b>
		DATE: <b>3/2/2010</b>			
DOCUMENT NUMBER:		CREATED / REVISED BY:	CHECKED BY:	APPROVED BY:	
<b>SD-70287-003</b>		<b>MKIPPER</b>	<b>JBELL</b>	<b>FSMITH</b>	