

■ General Description

The AME1300 combines a Low Dropout Regulator and a Microprocessor Reset Monitor in a space-saving MSOP-8 package. Total supply current is 50 μ A (typical), 20 to 60 times lower than in bipolar regulators .

The AME1300 has an extremely precise output with a typical accuracy of $\pm 1.5\%$. Other key features include ultra low noise operation, very low dropout voltage and internal feed-forward compensation for fast response to step changes in load. The AME1300 incorporates both over-temperature and over-current protection. When the shutdown control EN is low, the regulator output voltage falls to zero, RESETB output remains valid and supply current is reduced to 10 μ A(typical). The AME1300 is stable with an output capacitor of only 2.2 μ F and has a minimum output current of 300 mA.

An active low RESET is asserted when the detected voltage (V_{DET}) falls below the reset voltage threshold. The reset output remains low for 300msec(typical) after V_{DET} rises above reset threshold. The AME1300 also has a fast wake up response time (10 μ sec typically) when released from shutdown.

■ Features

- LDO with intergrated Microprocessor Reset Monitor Functionality
- Guaranteed 300mA Output
- Accurate to within 1.5%
- 50 μ A Quiescent Current
- Over-Temperature Shutdown
- Current Limiting
- Short Circuit Current Fold-back
- Noise Reduction Bypass Capacitor
- Power-Saving Shutdown Mode
- Space-Saving MSOP Package
- Factory Pre-set Output Voltages
- Low Temperature Coefficient
- All AME's Lead Free Products Meet RoHS Standards.

■ Applications

- Instrumentation
- Portable Electronics
- Wireless Devices
- Cellular / GSM / CDMA Phones
- PC Peripherals
- Battery Powered Widgets

■ Typical Applications

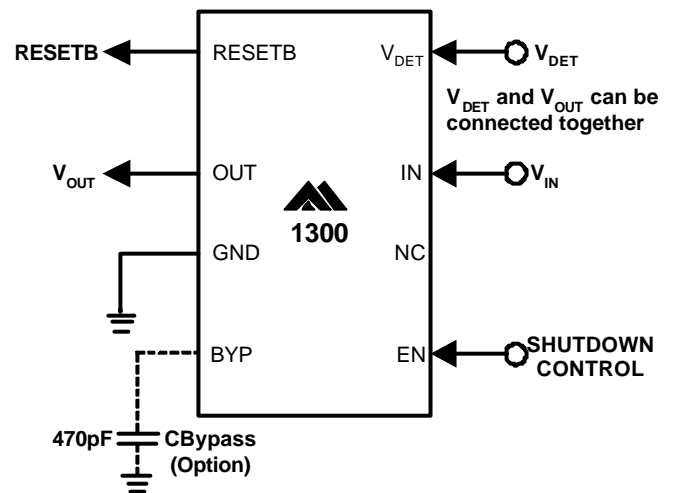

■ Pin Configuration

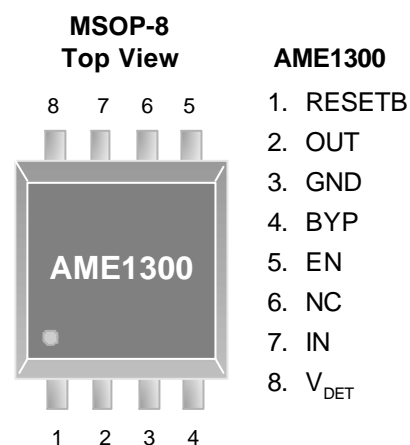

**Die Attach:
Conductive Epoxy**

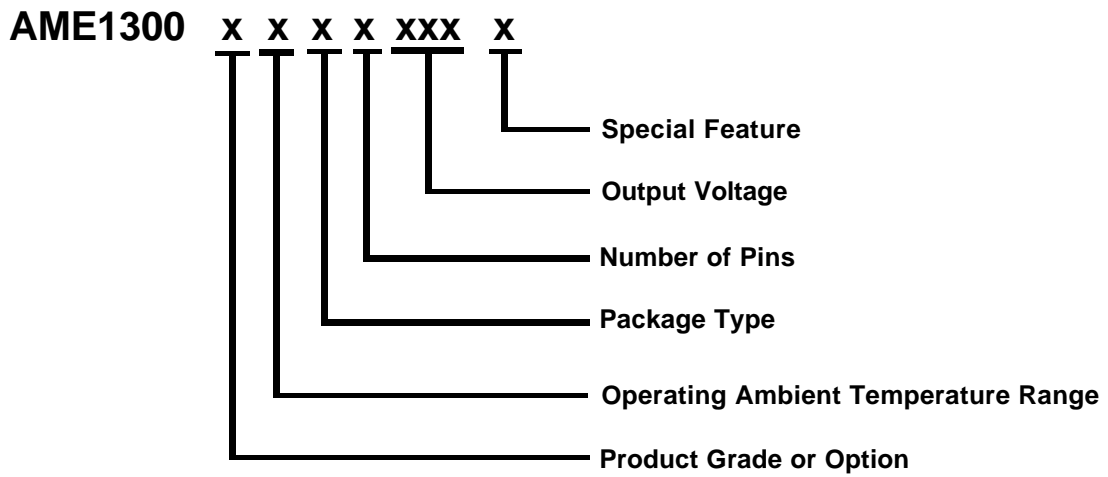
AME1300
■ Ordering Information

Product Grade or Option	Operating Ambient Temperature Range	Package Type	Number of Pins	Output Voltage	Special Feature
B: 3.0V C: 2.8V H: 2.7V J: 2.85V	E: -40°C to +85°C	Q: MSOP	A: 8	270: V=2.7V 280: V=2.8V 285: V=2.85V 300: V=3.0V	Z: Lead Free



AME1300

300mA CMOS LDO with RESET Function

■ Ordering Information

Part Number	Marking*	Output Voltage	Package	Operating Ambient Temperature Range
AME1300HEQA270	1300 Hyww	2.7V	MSOP-8	- 40°C to +85°C
AME1300HEQA270Z	1300 Hyww	2.7V	MSOP-8	- 40°C to +85°C
AME1300CEQA280	1300 Cyww	2.8V	MSOP-8	- 40°C to +85°C
AME1300CEQA280Z	1300 Cyww	2.8V	MSOP-8	- 40°C to +85°C
AME1300JEQA285	1300 Jyww	2.85V	MSOP-8	- 40°C to +85°C
AME1300JEQA285Z	1300 Jyww	2.85V	MSOP-8	- 40°C to +85°C
AME1300BEQA300	1300 Byww	3.0V	MSOP-8	- 40°C to +85°C
AME1300BEQA300Z	1300 Byww	3.0V	MSOP-8	- 40°C to +85°C

Note: yww represents the date code

* A line on top of the first letter represents lead free plating such as 1300

Please consult AME sales office or authorized Rep./Distributor for the availability of output voltage and package type .

AME1300
■ Absolute Maximum Ratings

Parameter	Maximum	Unit
Input Voltage	-0.3 to +7	V
EN, BYP Voltage	-0.3 to +7	V
Output Voltage	- 0.3 to $V_{IN} + 0.3$	V
Output Current	$P_D / (V_{IN} - V_{OUT})$	mA
ESD Classification	B*	

Caution: Stress above the listed absolute maximum rating may cause permanent damage to the device

* HBM B:2000~3999V

■ Recommended Operating Conditions

Parameter	Symbol	Rating	Unit
Ambient Temperature Range	T_A	- 40 to +85	°C
Junction Temperature Range	T_J	- 40 to +125	°C
Storage Temperature Range	T_{STG}	- 65 to +150	°C

■ Thermal Information

Parameter	Package	Die Attach	Symbol	Maximum	Unit
Thermal Resistance* (Junction to Case)	MSOP-8	Conductive Epoxy	θ_{JC}	100	°C / W
Thermal Resistance (Junction to Ambient)		Conductive Epoxy	θ_{JA}	206	°C / W
Internal Power Dissipation		Conductive Epoxy	P_D	625	mW
Maximum Junction Temperature				150	°C
Solder Iron(10 Sec)**				350	°C

* Measure θ_{JC} on center of molding compound if IC has no tab.

** MIL-STD-202G 210F

AME1300
■ Electrical Specifications
 $T_A = 25^\circ\text{C}$ unless otherwise noted, $V_{IN} = V_{O(NOM)} + 1\text{V}$, $I_O = 1\text{mA}$, $V_{EN} = V_{IN}$

Parameter	Symbol	Test Condition		Min	Typ	Max	Units
Input Voltage	V_{IN}			Note 1		6	V
Output Voltage Accuracy	V_O	$I_O = 1\text{mA}$		-1.5		1.5	%
Dropout Voltage	$V_{DROPOUT}$	$V_O = V_{O(NOM)} - 2.0\%$	$I_O = 0.1\text{mA}$		1	30	mV
			$I_O = 100\text{mA}$		70	130	
			$I_O = 300\text{mA}$		210	390	
Maximum Output Current	I_O	$V_O > 1.2\text{V}$		600	800		mA
Short Circuit Current	I_{SC}	$V_O = 0\text{V}$			300	600	mA
Quiescent Current	I_Q	$I_O = 0\text{mA}$			40	50	μA
Ground Pin Current	I_{GND}	$I_O = 1\text{mA}$ to 300mA			40		μA
Line Regulation	REG_{LINE}	$I_O = 1\text{mA}$ $V_{IN} = V_O + 1$ to $V_O + 2$	$2.0\text{V} \leq V_O < 4.0\text{V}$	-0.1	0.02	0.1	%
			$4.0\text{V} \leq V_O$	-0.4	0.2	0.4	%
Load Regulation	REG_{LOAD}	$I_O = 1\text{mA}$ to 300mA		-1	0.2	1	%
Over Temperature Shutdown	OTS				150		$^\circ\text{C}$
Over Temperature Hysteresis	OTH				30		$^\circ\text{C}$
V_O Temperature Coefficient	TC				30		ppm/ $^\circ\text{C}$
Power Supply Rejection	PSRR	$I_O = 100\text{mA}$ $C_O = 2.2\mu\text{F}$	$f = 1\text{kHz}$		50		dB
Output Voltage Noise	eN	$f = 10\text{Hz}$ to 100kHz $I_O = 10\text{mA}$	$C_O = 2.2\mu\text{F}$		30		μVrms
EN Input Threshold	V_{EH}	$V_{IN} = 5\text{V}$		2.0		V_{in}	V
	V_{EL}	$V_{IN} = 5\text{V}$		0		0.4	V
EN Input Bias Current	I_{EH}	$V_{EN} = V_{IN}$, $V_{IN} = 5\text{V}$				0.5	μA
	I_{EL}	$V_{EN} = 0\text{V}$, $V_{IN} = 5\text{V}$				0.1	μA
Shutdown Supply Current	I_{SD}	$V_{IN} = 5\text{V}$, $V_O = 0\text{V}$, $V_{EN} = 0$				10	μA
Shutdown Output Voltage	$V_{O,SD}$	$I_O = 0.4\text{mA}$, $V_{EN} = 0$		0		0.4	V

 Note 1: $V_{IN(min)} = V_{OUT} + V_{DROPOUT}$

AME1300
■ Electrical Specifications(contd.)
RESET Output

Parameter	Symbol	Test Condition		Min	Typ	Max	Units
V_{DET} Range	V_{DET}	$T_A = -40$ to $+85^\circ\text{C}$		1		5.5	V
Reset Threshold	V_{TH}	$T_A = 25^\circ\text{C}$		2.59	2.63	2.67	V
		$T_A = -40$ to $+85^\circ\text{C}$		2.58		2.68	
RESET Threshold Tempco					30		ppm
RESETB Output Voltage Low	V_{OL}	$V_{DET} < V_{TH}$ min	$I_{SINK}=1.2\text{mA}$, $T_A = -40$ to $+85^\circ\text{C}$			0.5	V
RESETB Output Voltage High	V_{OH}	$V_{DET} > V_{TH}$ max	$I_{SOURCE}=0.5\text{mA}$, $T_A = -40$ to $+85^\circ\text{C}$	$0.8V_{DET}$			V
V_{DET} to Reset Delay	T_{D1}	$V_{DET} = V_{TH} - 100\text{mV}$, $T_A = -40$ to $+85^\circ\text{C}$			40		μs
Reset Active Timeout Period*	T_{D2}	$T_A = -40 \sim +85^\circ\text{C}$		140	210	500	mS

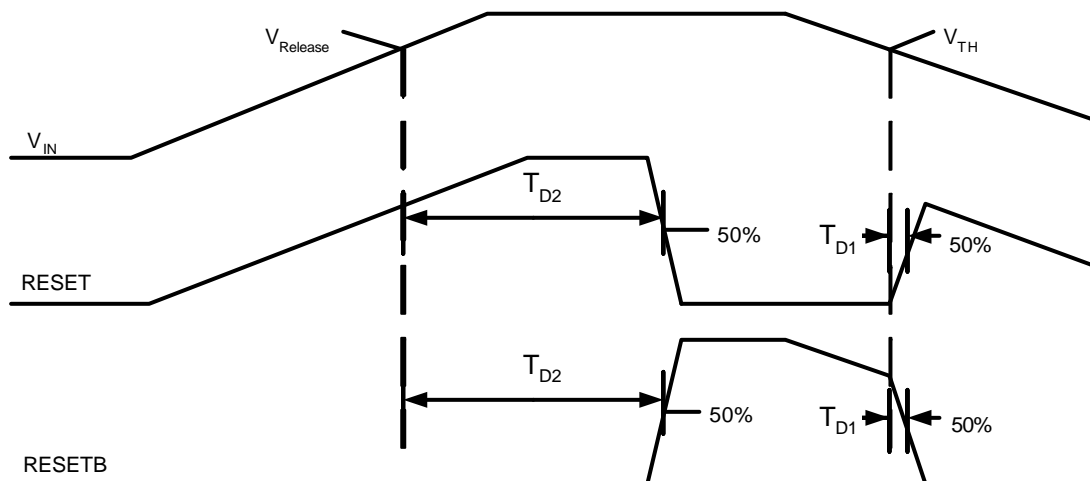
■ Timing Diagram

AME1300

■ Detailed Description

The AME1300 is a combination of a fixed output, low drop-out regulator and microprocessor monitor. Unlike bipolar regulators, the AME1300 supply current does not increase with load current. In addition, V_{OUT} remains stable and within regulation at very low load currents (an important consideration in RTC and CMOS RAM battery backup applications) as well as with any type of capacitor (see below). AME1300 pin functions are detailed below:

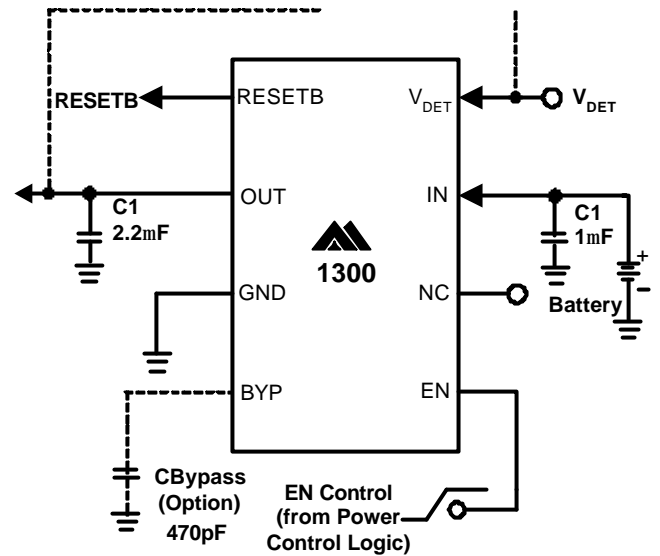

■ Pin Description

Pin Number	Pin Name	Pin Description
1	RESETB	RESETB output remains low while V_{DET} is below the reset voltage threshold, and for 300msec V_{DET} rises above reset threshold.
2	OUT	Regulated Voltage Output.
3	GND	Ground Terminal.
4	BYP	Reference Bypass Input. Connecting a 1000pF to this input further reduces output noise.
5	EN	Shutdown Control Input. The regulator is fully enabled when a logic high is applied to this input. The regulator enters shutdown when a logic low is applied to this input. During shutdown, regulator output voltage falls to zero, RESETB output remains valid and supply current is reduced to 10 μ A (typ.)
6	NC	No connect.
7	IN	Power Supply Input.
8	V_{DET}	Detected input Voltage. V_{DET} and V_{OUT} can be connected together.

AME1300

■ Enable

When actively pulled low, the PMOS pass transistor shuts off, and all internal circuits are powered down. In this state, the quiescent current is less than 10 μ A. This pin behaves much like an electronic switch.

RESETB Output

The RESETB output is driven active low within 40 μ sec of V_{DET} falling through the reset threshold. RESETB is maintained active for a minimum of 140msec after V_{DET} rises above the reset threshold. The AME1300 has an active-low RESETB output. The output of the AME1300 is guaranteed valid down to $V_{DET} = 1V$ and is optimized to reject fast transient glitches on the V_{DET} line.

■ External Capacitors

The AME1300 is stable with an output capacitor to ground of 2.2 μ F or greater. Ceramic capacitors have the lowest ESR, and will offer the best AC performance. Conversely, Aluminum Electrolytic capacitors exhibit the highest ESR, resulting in the poorest AC response. Unfortunately, large value ceramic capacitors are comparatively expensive. One option is to parallel a 0.1 μ F ceramic capacitor with a 10 μ F Aluminum Electrolytic. The benefit is low ESR, high capacitance, and low overall cost.

A second capacitor is recommended between the input and ground to stabilize V_{in} . The input capacitor should be at least 0.1 μ F to have a beneficial effect.

A third capacitor can be connected between the BY-PASS pin and GND. This capacitor can be a low cost Polyester Film variety between the value of 0.001~0.01 μ F. A larger capacitor improves the AC ripple rejection, but also makes the output come slowly. This "Soft" turn-on is desirable in some applications to limit turn-on surges.

All capacitors should be placed in close proximity to the pins. A "Quiet" ground termination is desirable. This can be achieved with a "Star" connection.

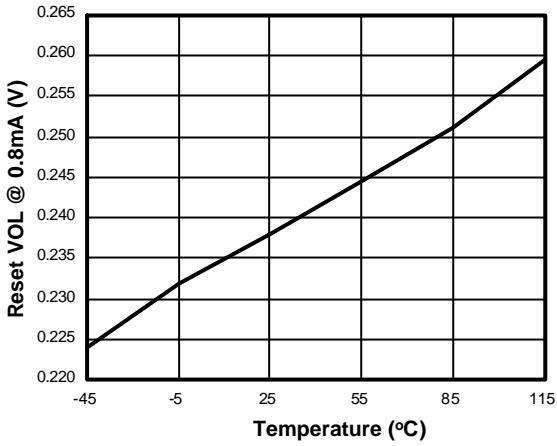
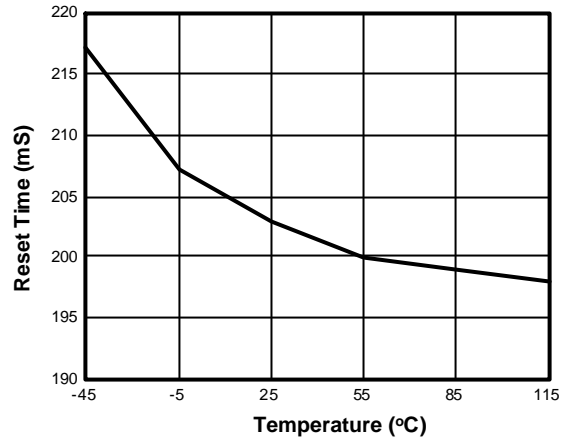
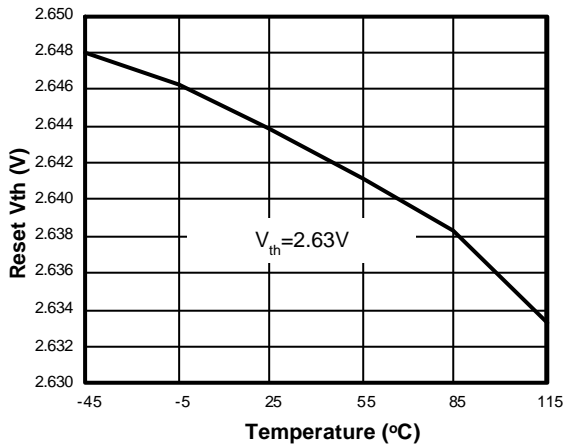
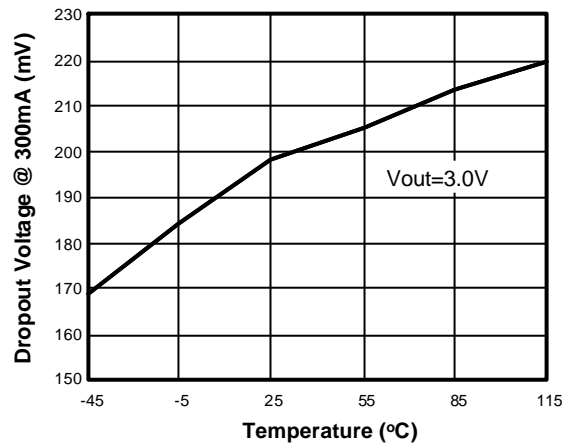
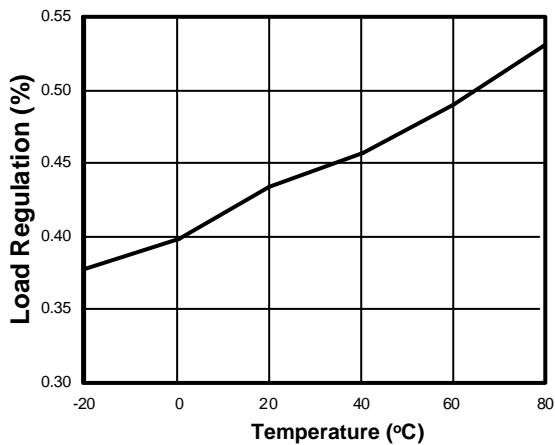
Reset VOL vs. Temperature

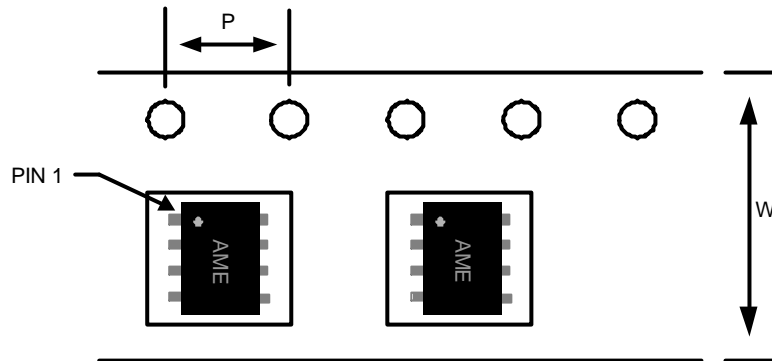
Reset Time vs. Temperature

Reset Vth vs. Temperature

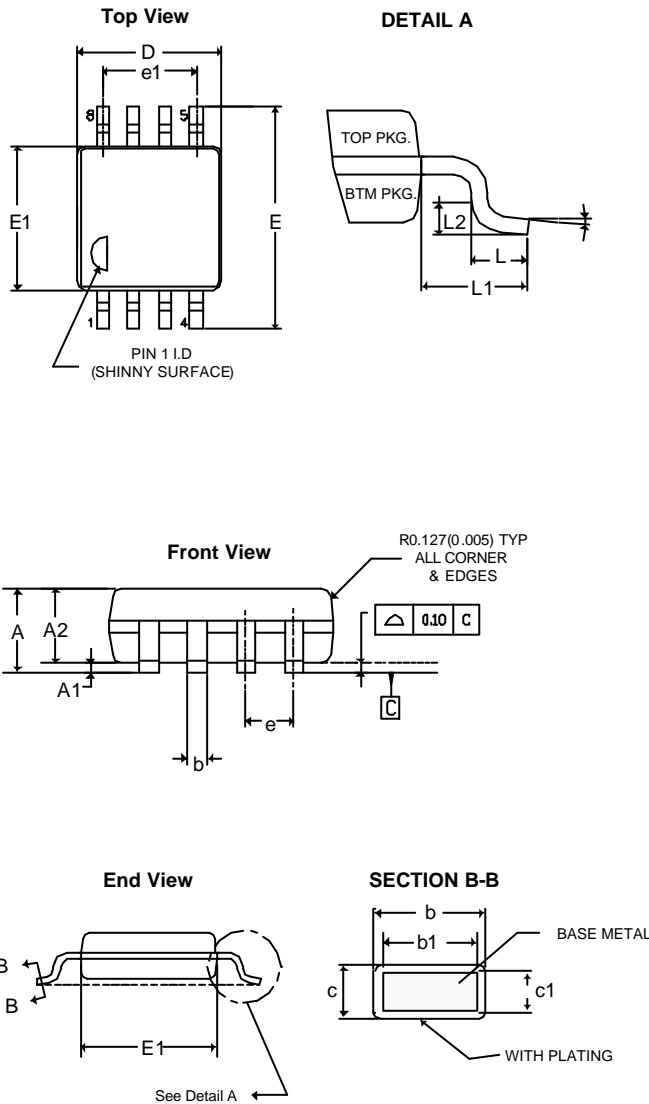
Dropout Voltage vs. Temp.

Load Regulation vs. Temp.

AME1300
■ Tape and Reel Dimension
MSOP-8

Carrier Tape, Number of Components Per Reel and Reel Size

Package	Carrier Width (W)	Pitch (P)	Part Per Full Reel	Reel Size
MSOP-8	12.0±0.1 mm	4.0±0.1 mm	4000pcs	330±1 mm

■ Package Dimension
MSOP-8

SYMBOLS	MILLIMETERS		INCHES	
	MIN	MAX	MIN	MAX
A	-	1.07	-	0.04197
A₁	0.05	0.20	0.002	0.008
A₂	0.81	0.92	0.032	0.036
b	0.28	0.38	0.011	0.015
b₁	0.28	0.33	0.011	0.013
c	0.13	0.23	0.005	0.009
c₁	0.13	0.17	0.005	0.006
D	2.90	3.10	0.114	0.122
E	4.77	4.98	0.188	0.196
E₁	2.90	3.10	0.114	0.122
e	0.65 TYP		0.0255 TYP	
e₁	1.95 TYP		0.0767 TYP	
L	0.406	0.686	0.01598	0.02701
L₁	0.94 REF		0.037 REF	
L₂	0.254 TYP		0.010 TYP	
q	0°	8°	0°	8°

NOTE:

- Controlling dimension : Millimeter, converted inchdimension are not necessarily exact.
- Dimensioning and tolerancing per ansi Y14.5m-1994.
- Dimension "d" does not include mold flash, protrusion or gate burr, mold flash, protrusion and gate burr shall not exceed 0.15mm(0.006") per side. Dimension e1 do not include inter-lead flash or protrusion, inter-lead flash and protrusion shall not exceed 0.15mm(0.006") per side.
- The package top be smaller than the package bottom. Dimension d and e1 are determined at outermost extremes of the plastic body exclusive of mold flash, tie bar burrs, gate burrs and interlead flash, but including any mismatch between the top and bottom of the plastic body.
- Dimension 'b' does not include dambar protrusion. Allowable dambar protrusion shall be 0.08mm(0.0031) total in excess of the "b" dimension at maximum material condition.



www.ame.com.tw
E-Mail: sales@ame.com.tw

Life Support Policy:

These products of AME, Inc. are not authorized for use as critical components in life-support devices or systems, without the express written approval of the president of AME, Inc.

AME, Inc. reserves the right to make changes in the circuitry and specifications of its devices and advises its customers to obtain the latest version of relevant information.

© AME, Inc. , November 2008
Document: 2006&7-DS1300-C.02

Corporate Headquarter
AME, Inc.

2F, 302 Rui-Guang Road, Nei-Hu District
Taipei 114, Taiwan.

Tel: 886 2 2627-8687

Fax: 886 2 2659-2989