

## High-density Signal Conditioners 10-RACK

0: Specify

### THERMOCOUPLE TRANSMITTER

#### Functions & Features

- Accepting direct input from a thermocouple and providing two standard process signals
- 5-segment linearization
- Burnout protection
- High-accuracy cold junction compensation
- Optional second channel output available at the front terminals and at the Standard Rack connector

#### Typical Applications

- High-accuracy cold junction compensation benefits narrow span measurements
- 0.1  $\mu$ A burnout sensing enables long distance transmission with minimum offset drifts
- Electric furnace (isolation)
- No burnout type can connect to a single T/C in parallel with a recorder

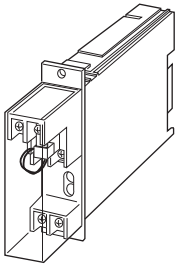

### MODEL: 10TS-[1][2][3]-R[4]

#### ORDERING INFORMATION

- Code number: 10TS-[1][2][3]-R[4]  
Specify a code from below for each [1] through [4].  
(e.g. 10TS-2A6-R/BL/Q)
- Temperature range (e.g. 0 - 800 °C)
- Specify the specification for option code /Q  
(e.g. /C01)

#### [1] INPUT THERMOCOUPLE

- 1: (PR) (Usable Range 0 to 1760°C, 32 to 3200°F)
- 2: K (CA) (Usable range -270 to +1370°C, -454 to +2498°F)
- 3: E (CRC) (Usable range -270 to +1000°C, -454 to +1832°F)
- 4: J (IC) (Usable range -210 to +1200°C, -346 to +2192°F)
- 5: T (CC) (Usable range -270 to +400°C, -454 to +752°F)
- 6: B (RH) (Usable range 0 to 1820°C, 32 to 3308°F)
- 7: R (Usable range -50 to +1760°C, -58 to +3200°F)
- 8: S (Usable range -50 to +1760°C, -58 to +3200°F)
- N: N (Usable range -270 to +1300°C, -454 to +2372°F)

#### [2] OUTPUT 1

##### Current

- A: 4 - 20 mA DC (Load resistance 600  $\Omega$  max.)
- B: 2 - 10 mA DC (Load resistance 1200  $\Omega$  max.)
- C: 1 - 5 mA DC (Load resistance 2400  $\Omega$  max.)
- D: 0 - 20 mA DC (Load resistance 600  $\Omega$  max.)
- E: 0 - 16 mA DC (Load resistance 750  $\Omega$  max.)
- F: 0 - 10 mA DC (Load resistance 1200  $\Omega$  max.)
- G: 0 - 1 mA DC (Load resistance 12 k $\Omega$  max.)

##### Voltage

- 1: 0 - 10 mV DC (Load resistance 10 k $\Omega$  min.)
- 2: 0 - 100 mV DC (Load resistance 100 k $\Omega$  min.)
- 3: 0 - 1 V DC (Load resistance 100  $\Omega$  min.)
- 4: 0 - 10 V DC (Load resistance 1000  $\Omega$  min.)
- 5: 0 - 5 V DC (Load resistance 500  $\Omega$  min.)
- 6: 1 - 5 V DC (Load resistance 500  $\Omega$  min.)

#### [3] OUTPUT 2

0: None

##### Voltage

- 6: 1 - 5 V DC (Load resistance 5000  $\Omega$  min.)

#### POWER INPUT

##### DC Power

R: 24 V DC

(Operational voltage range 24 V  $\pm$ 10 %, ripple 10 %p-p max.)

#### [4] OPTIONS (multiple selections)

##### Burnout

blank: Upscale burnout

/BL: Downscale burnout

/BN: No burnout

##### CJC Sensor

blank: With Cold Junction Compensation Sensor

/N: Without Cold Junction Compensation Sensor

##### Other Options

blank: none

/Q: Option other than the above (specify the specification)

#### SPECIFICATIONS OF OPTION: Q

##### COATING (For the detail, refer to M-System's web site.)

/C01: Silicone coating

/C02: Polyurethane coating

/C03: Rubber coating

#### GENERAL SPECIFICATIONS

**Construction:** Rack-mounted; terminal access via screw terminals at the front and via card-edge connector at the

rear; terminal cover provided

## Connection

**Input:** M3.5 screw terminals (torque 0.8 N·m)

**Output:** Card-edge connector and M3.5 screw terminals (torque 0.8 N·m)

**Power input:** Supplied from card-edge connector

**Screw terminal:** Nickel-plated steel

**Housing material:** Flame-resistant resin (black)

**Isolation:** Input to output 1 to output 2 to power

**Overrange output:** Approx. -10 to +120 % at 1 - 5 V

**Zero adjustment:** -5 to +5 % (front)

**Span adjustment:** 95 to 105 % (front)

**At burnout:** Downscale  $\leq$  -10 %, Upscale  $\geq$  110 %

**Linearization:** Standard

**Cold junction compensation (CJC):** CJC sensor attached to the input terminals as standard; No CJC optional (B thermocouple is without CJC as standard.)

## INPUT SPECIFICATIONS

**Input resistance:** 20 k $\Omega$  minimum

**Burnout sensing:** 0.1  $\mu$ A

**Minimum span:** 3 mV

**Offset:** Max. 1.5 times span

**Minimum span (in °C)**

(PR): 370°C

K (CA): 75°C

E (CRC): 50°C

J (IC): 60°C

T (CC): 75°C

B (RH): 780°C

R: 360°C

S: 380°C

N: 110°C

**Minimum span (in °F)**

(PR): 670°F

K (CA): 140°F

E (CRC): 90°F

J (IC): 110°F

T (CC): 140°F

B (RH): 1410°F

R: 650°F

S: 690°F

N: 200°F

For the temperatures that range below 0°C, the transmitter may partially not satisfy the described accuracy. Consult factory.

## INSTALLATION

**Current consumption:** Approx. 30mA with voltage output 1  
Approx. 60mA with current output 1

**Operating temperature:** -5 to +55°C (23 to 131°F)

**Operating humidity:** 30 to 90 %RH (non-condensing)

**Mounting:** Standard Rack 10BXX

**Weight:** 200 g (0.44 lb)

## PERFORMANCE in percentage of span

**Accuracy:**  $\pm 0.4$  % (at over 400°C or 750°F for R, S and PR; over 770°C or 1420°F for B)

**Cold junction compensation error**

(at 20°C  $\pm 10$ °C or 68°F  $\pm 18$ °F; with CJC sensor)

K, E, J, T, N:  $\pm 0.5$ °C or  $\pm 0.9$ °F

S, R, PR:  $\pm 1$ °C or  $\pm 1.8$ °F

**Temp. coefficient:**  $\pm 0.015$  %/°C ( $\pm 0.008$  %/°F)

(at over 400°C or 750°F for R, S and PR; over 770°C or 1420°F for B)

**Response time:**  $\leq 0.5$  sec. (0 - 90 %)

**Burnout response:**  $\leq 10$  sec.

**Line voltage effect:**  $\pm 0.1$  % over voltage range

**Insulation resistance:**  $\geq 100$  M $\Omega$  with 500 V DC

**Dielectric strength:** 500 V AC @ 1 minute

(input to output 1 to output 2 to power)

1500 V AC @ 1 minute (input or output or power to ground)

## DIMENSIONS unit: mm (inch)

Terminal 3 is deleted with CJC sensor attached models.

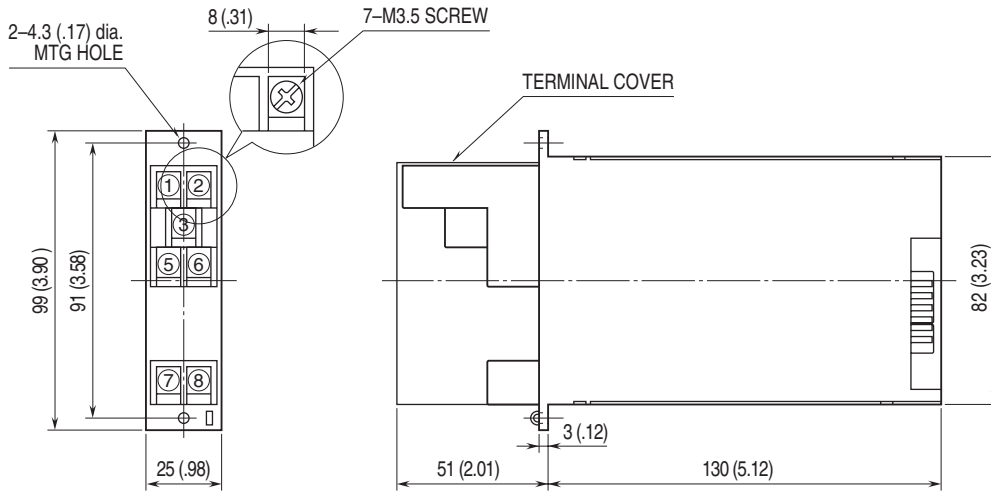

## TERMINAL ASSIGNMENTS

CJC SENSOR\*  
(model: CJM)



\*Deleted with Option /N

## SCHEMATIC CIRCUITRY & CONNECTION DIAGRAM

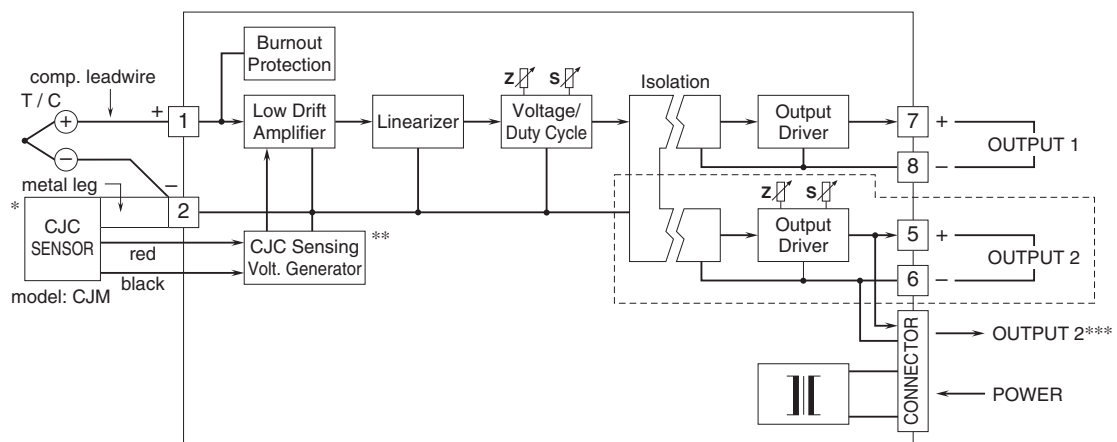

\* Deleted with Option /N.

\*\* Deleted with Option /N or B thermocouple.

\*\*\*1 output type has the output 1 connected to the card-edge connector in parallel.

Remark 1) The section enclosed by broken line is only for 2nd output channel.



Specifications are subject to change without notice.