

## GENERAL DESCRIPTION

The EV3209DJ-00A is the evaluation board for the MP3209. The MP3209 is a current mode step up converter intended for small, low power applications. The MP3209 switches at 1.3MHz and allows the use of tiny, low cost capacitors and inductors to achieve a solution less than 1mm in height. Internal soft start results in small inrush current and extends battery life.

The MP3209 includes under-voltage lockout, current limiting, and thermal overload protection to prevent damage in the event of an output overload. The MP3209 is available in small 5-pin TSOT23 and 2mm x 2mm ultra-thin QFN 8-pin packages.

## ELECTRICAL SPECIFICATION

Parameter	Symbol	Value	Units
Input Voltage	$V_{IN}$	2.5 to 6	V
Output Voltage	$V_{OUT}$	15	V

## FEATURES

- 2.5V to 6V Input Voltage Range
- On Board Power MOSFET
- Uses Tiny Capacitors and Inductors
- 1.3MHz Fixed Switching Frequency
- Internally Compensated
- Internal Soft-Start
- Operates with Input Voltage as Low as 2.5V and Output Voltage as High as 22V
- UVLO, Thermal Shutdown
- Internal Current Limit
- Available in TSOT23-5 and Ultra-Thin 2x2 QFN Packages

## APPLICATIONS

- Cell Phones
- External Modems
- Small LCD Displays
- OLED Drivers

"MPS" and "The Future of Analog IC Technology" are Registered Trademarks of Monolithic Power Systems, Inc.

## EV3209DJ-00A EVALUATION BOARD



Dimensions (1.6" by 1.8" X x 1.8" Y x 0.4" Z)

Board Number	MPS IC Number
EV3209DJ-00A	MP3209DJ

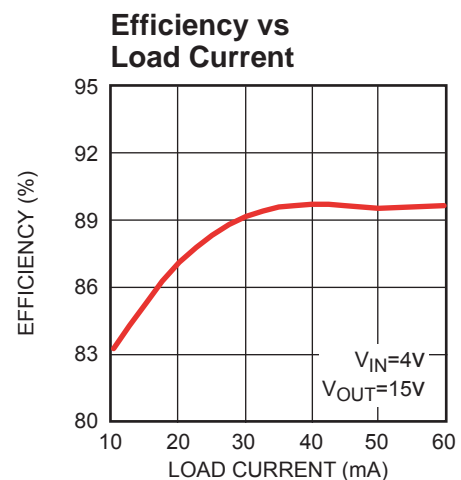

## EVALUATION BOARD SCHEMATIC

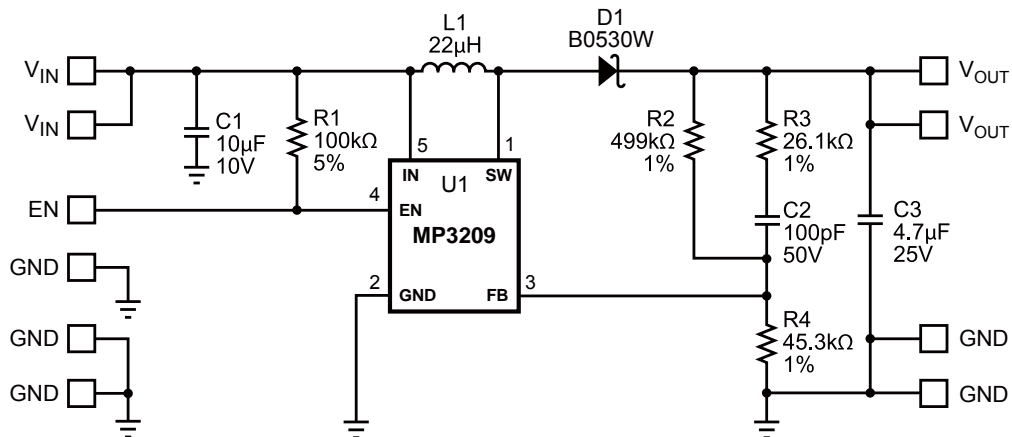

## EV3209DJ-00A BILL OF MATERIALS

Qty	Ref	Value	Description	Package	Manufacturer	Manufacturer P/N
1	C1	10µF	Ceramic Cap., 10V, X5R	1210	TDK	C3225X5R1A106K
1	C3	4.7µF	Ceramic Cap., 25V, X7R	1210	TDK	C3225X7R1E475M
1	C2	100pF	Ceramic Cap., 50V, COG	0603	TDK	C16-8COG1H101J
1	L1	22µH	22µH, 0.49A, SMD	SMD	TDK	VLCF4018-220MR49-2
1	D1	B0530W	Schottky Diode 30V,0.5A	SOD-123	Diodes Inc	B0530W
1	R1	100k	Film Res., 5%	0603	Royalohm	0603J0104T5E
1	R2	499k	Film Res., 1%	0603	Yageo	RC0603FR-07499KL
1	R3	26.1k	Film Res., 1%	0603	Yageo	RC0603FR-0726K1L
1	R4	45.3k	Film Res., 1%	0603	Yageo	RC0603FR-0745K3L
1	U1	MP3209DJ	Step-Up Converter	SOT23-5	MPS	MP3209DJ-R16

**PRINTED CIRCUIT BOARD LAYOUT**

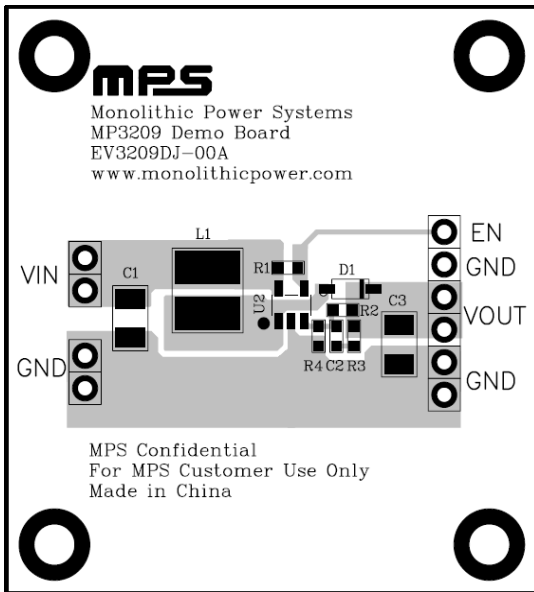

**Figure 1—Top Layer**

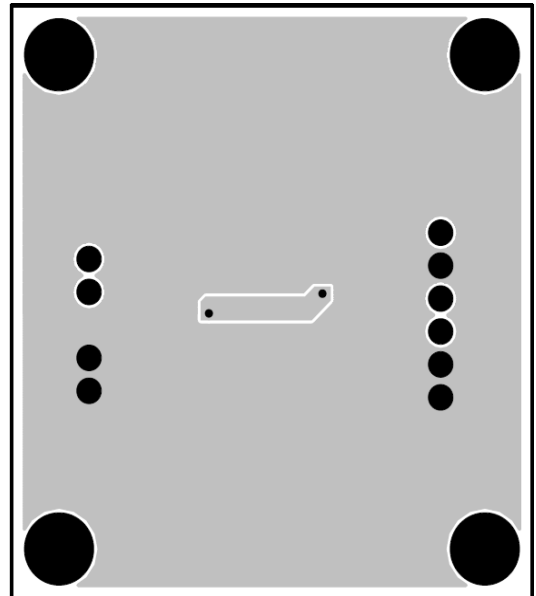

**Figure 2—Bottom Layer**

## QUICK START GUIDE

The output voltage of this board is set to 15V. The board layout accommodates most commonly used inductors and output capacitors.

1. Preset Power Supply to  $2.5V \leq V_{IN} \leq 6V$ .
2. Turn Power Supply off.
3. Connect Power Supply terminals to:
  - Positive (+): IN
  - Negative (-): GND
4. Connect Load to:
  - Positive (+): OUT
  - Negative (-): GND
5. Turn Power Supply on after making connections.
6. The MP3209 is enabled on the evaluation board once  $V_{IN}$  is applied. To disable the MP3209, short EN to GND.
7. The output voltage  $V_{OUT}$  can be changed by varying R4. Calculate the new value using the fomula:

$$R4 = \left( \frac{V_{FB}}{V_O - V_{FB}} \right) \times R2$$

Where  $V_{FB} = 1.25V$  and  $R2 = 499k\Omega$

For example, for  $V_{OUT} = 15V$

$$R4 = \left( \frac{1.25}{15 - 1.25} \right) \times 499k\Omega = 45.3k\Omega$$

Therefore use a 45.3 k $\Omega$  standard 1% value.

**NOTICE:** The information in this document is subject to change without notice. Please contact MPS for current specifications. Users should warrant and guarantee that third party Intellectual Property rights are not infringed upon when integrating MPS products into any application. MPS will not assume any legal responsibility for any said applications.