

Features

- HIGH GAIN - TWO STAGES: 27.5 dB (TYP.)
- LOW NOISE: <3.0 dB (TYP.)
- HIGH POWER OUTPUT: 15.0 dBm (TYP.)
- WIDE POWER SUPPLY RANGE: 5 TO 15 VOLTS

Description

The A66-1 RF amplifier is a discrete hybrid design, which uses thin film manufacturing processes for consistent performance and high reliability.

This 2 stage bipolar transistor feedback amplifier design displays impressive performance over a broadband frequency range. An active DC biasing network insures temperature-stable performance.

Both TO-8 and Surface Mount packages are hermetically sealed, and MIL-STD-883 environmental screening is available.

Ordering Information

Part Number	Package
A66-1	TO-8
SMA66-1	Surface Mount
CA66-1 **	SMA Connectorized

** The connectorized version is not RoHs compliant.

Product Image



Electrical Specifications: $Z_0 = 50\Omega$, $V_{CC} = +15 V_{DC}$

Parameter	Units	Typical	Guaranteed	
		25°C	0° to 50°C	-54° to +85°C*
Frequency	MHz	5-1200	10-1000	10-1000
Small Signal Gain (min)	dB	27.5	26.0	25.5
Gain Flatness (max)	dB	±0.4	±0.7	±1.0
Reverse Isolation	dB	33		
Noise Figure (max)	dB	2.9	3.5	4.0
Power Output @ 1 dB comp. (min)	dBm	15.0	14.5	14.0
IP3	dBm	+28		
IP2	dBm	+38		
Second Order Harmonic IP	dBm	+43		
VSWR Input / Output (max)		1.5:1 / 1.5:1	1.8:1 / 1.8:1	2.0:1 / 2.0:1
DC Current @ 15 Volts (max)	mA	66	69	72

Absolute Maximum Ratings

Parameter	Absolute Maximum
Storage Temperature	-62°C to +125°C
Case Temperature	+125°C
DC Voltage	+17 V
Continuous Input Power	6 dBm
Short Term Input power (1 minute max.)	50 mW
Peak Power (3 µsec max.)	0.5 W
"S" Series Burn-In Temperature (case)	+125°C

Thermal Data: $V_{CC} = +15 V_{DC}$

Parameter	Rating
Thermal Resistance θ_{jc}	145°C/W
Transistor Power Dissipation P_d	0.419 W
Junction Temperature Rise Above Case T_{jc}	61°C

* Over temperature performance limits for part number CA66-1, guaranteed from 0°C to +50°C only.

ADVANCED: Data Sheets contain information regarding a product M/A-COM Technology Solutions is considering for development. Performance is based on target specifications, simulated results, and/or prototype measurements. Commitment to develop is not guaranteed.

PRELIMINARY: Data Sheets contain information regarding a product M/A-COM Technology Solutions has under development. Performance is based on engineering tests. Specifications are typical. Mechanical outline has been fixed. Engineering samples and/or test data may be available. Commitment to produce in volume is not guaranteed.

• **North America** Tel: 800.366.2266 • **Europe** Tel: +353.21.244.6400
 • **India** Tel: +91.80.4155721 • **China** Tel: +86.21.2407.1588
 Visit www.macomtech.com for additional data sheets and product information.

M/A-COM Technology Solutions Inc. and its affiliates reserve the right to make changes to the product(s) or information contained herein without notice.

A66-1 / SMA66-1

Cascadable Amplifier
10 to 1000 MHz

Rev. V3

Typical Performance Curves at +25°C

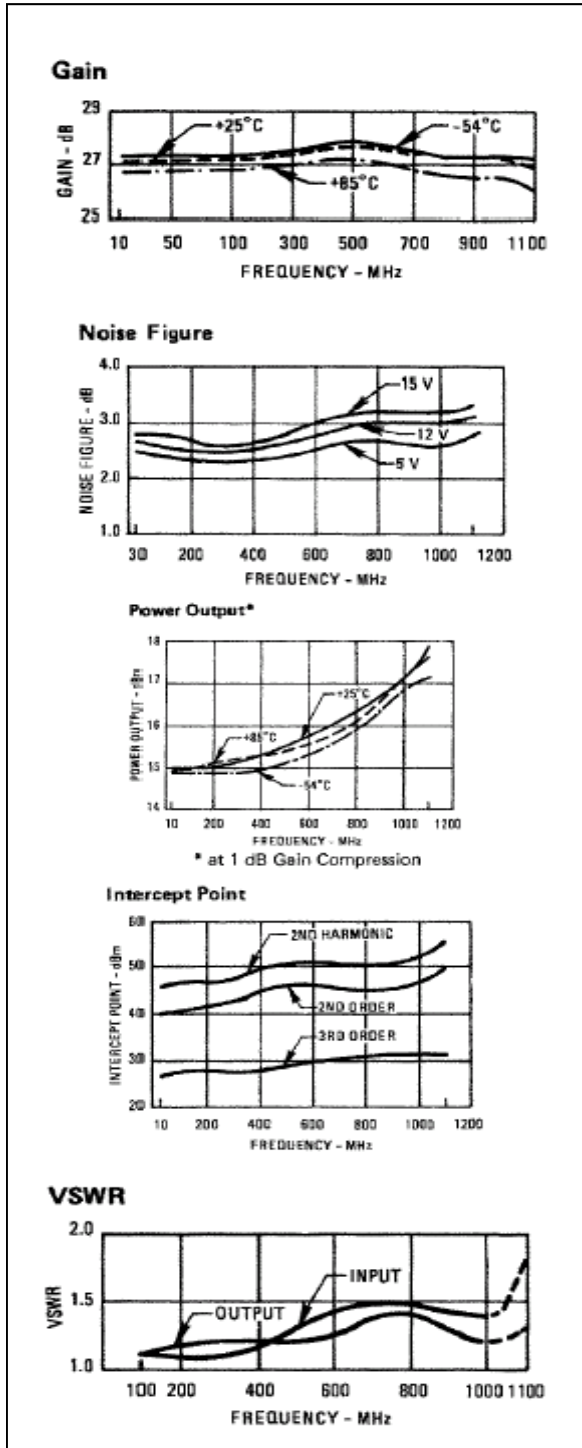

Outline Drawing: TO-8 *



Outline Drawing: Surface Mount *

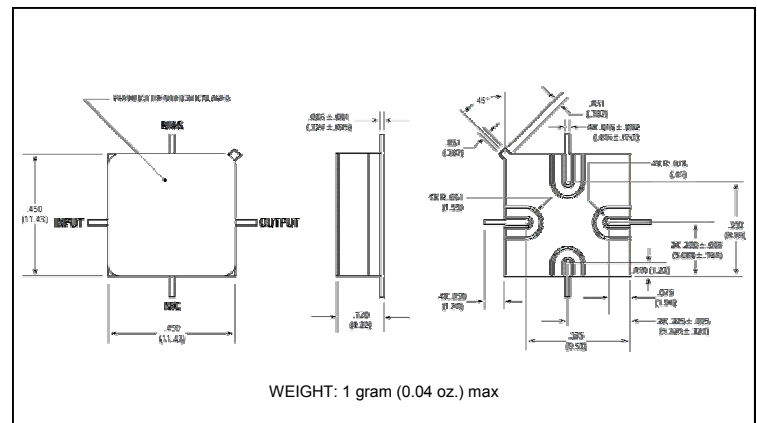

Outline Drawing: SMA Connectorized *

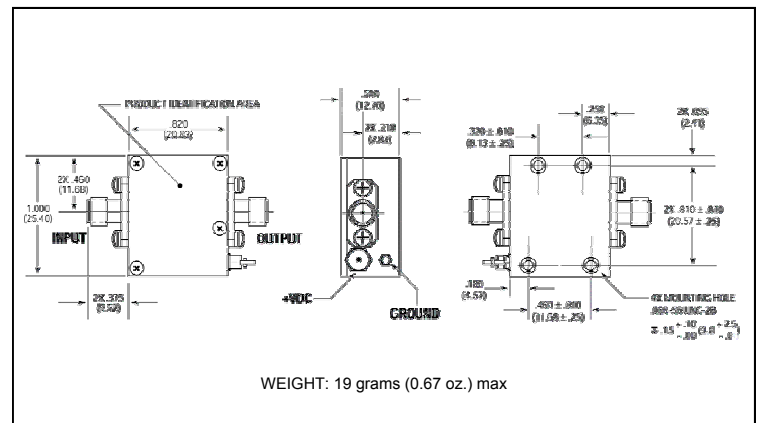

* Dimensions are inches (millimeters) ±0.015 (0.38) unless otherwise specified.

ADVANCED: Data Sheets contain information regarding a product M/A-COM Technology Solutions is considering for development. Performance is based on target specifications, simulated results, and/or prototype measurements. Commitment to develop is not guaranteed.
PRELIMINARY: Data Sheets contain information regarding a product M/A-COM Technology Solutions has under development. Performance is based on engineering tests. Specifications are typical. Mechanical outline has been fixed. Engineering samples and/or test data may be available. Commitment to produce in volume is not guaranteed.

• **North America** Tel: 800.366.2266 • **Europe** Tel: +353.21.244.6400
 • **India** Tel: +91.80.4155721 • **China** Tel: +86.21.2407.1588
 Visit www.macomtech.com for additional data sheets and product information.

M/A-COM Technology Solutions Inc. and its affiliates reserve the right to make changes to the product(s) or information contained herein without notice.