

677 EMC series



features



- EMC version with internal stainless steel mesh
- Ø8.1mm mounting
- Black chrome plated aluminium housing with a conductive rubber panel seal
- Sealed to IP67
- Internal reverse protection diode fitted as standard in all voltage models
- Pack Quantity = 10 Pieces

specifications

Typical characteristics (Ta = 25°C)

Part Number	Colour	Voltage Vac/dc	Current DC (mA)	Luminous Intensity (mcd)	Wave Length (nm)	Operating Temp. (°C)	Storage Temp. (°C)	De-rating Graphs
677-501-21-53	Red	12 Vdc	18	600	630	-40 - +80	-40 - +100	D
677-521-21-53	Yellow	12 Vdc	18	600	585	-40 - +80	-40 - +100	D
677-532-21-53	Green	12 Vdc	18	800	515	-40 - +80	-40 - +100	F
677-930-21-53	Blue	12 Vdc	18	140	465	-30 - +85	-40 - +100	U
677-997-21-53	White	12 Vdc	18	27000	* See below	-30 - +85	-40 - +100	I
677-501-23-53	Red	24 - 28 Vdc	19	600	630	-40 - +80	-40 - +100	D
677-521-23-53	Yellow	24-28 Vdc	19	600	585	-40 - +80	-40 - +100	D
677-532-23-53	Green	24-28 Vdc	19	800	515	-40 - +80	-40 - +100	F
677-930-23-53	Blue	24 - 28 Vdc	19	140	465	-30 - +85	-40 - +100	U
677-997-23-53	White	24-28 Vdc	19	27000	* See below	-30 - +85	-40 - +100	I

997F-C	*Typical emission colour White			
x	0.31	-	-	-
y	0.32	-	-	-

- Intensities (lv) and colour shades of white (x, y co-ordinates) may vary between LEDs within a batch
- Products must be de-rated according to the de-rating information. Each de-rating graph refers to specific LEDs. Please refer to graphs on page 3.
- Luminous intensity is measured at 20mA on a discrete LED unless otherwise stated.

to order

to order please contact us on: t: +44 (0)1229 582 430
f: +44 (0)1229 585 155 e: sales@marl.co.uk w: www.leds.co.uk

© marl international limited technical documentation has been designed by marl international limited for the intention of providing information, which must not be copied or released to a third party without prior written consent from marl international limited. the information provided does not constitute part of any order or contract and should not be regarded as a representation relating to either products or service. no responsibility can be assumed for inaccuracies or printing errors. marl international limited reserve the right to alter without notice the specification or any conditions of supply for product or service.



high performance panel lamps

677 EMC series



technical data

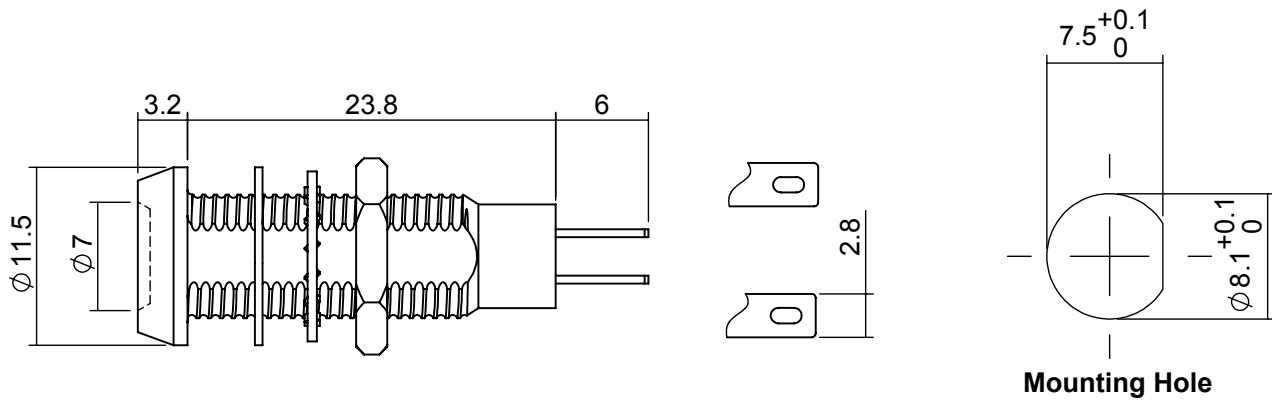

Dimensions in mm (typical)
Not to scale

Anode termination denoted by red indicator
Mounting hole to be clean and burr free

housing material

push on connectors

Body Nut Panel Seal Fresnel Lens Encapsulation Lock Washer Termination Header	Black Anodised Aluminium Bright Nickel Plated Brass Conductive Rubber Silver Flash Coated Brass PC5430 Resin Spring Steel Silver Flash Coated Brass -	<p>925-000-00 is brass tin plated - for use with 677 series lamps Dimensions in mm (typical). Not to scale.</p>
--	--	---

technical characteristics

Series	Max. Power Dissipation	Max. Reverse Voltage	Panel Cutout	Nut Mounting Torque	Min. Mounting Centres	Max. Panel Thickness
677	700	3*/1000^	8.1	0.6	14.5	1.5 - 13.0
units	mW	Vdc	mm	Nm	mm	mm

* = Current Version ^ = Voltage Version

optional flying lead terminations

Order Code Suffix	Supply Voltage	Wire Colour	Wire Length	No/Diameter of Conductor	Diameter Insulation	Comments
19	DC products	Red-anode/ Black-cathode	1000mm	19/0.15mm	1.2mm	Customised lengths available

to order

to order please contact us on: t: +44 (0)1229 582 430 f: +44 (0)1229 585 155
e: sales@marl.co.uk w: www.leds.co.uk

© marl international limited technical documentation has been designed by marl international limited for the intention of providing information, which must not be copied or released to a third party without prior written consent from marl international limited. the information provided does not constitute part of any order or contract and should not be regarded as a representation relating to either products or service. no responsibility can be assumed for inaccuracies or printing errors. marl international limited reserve the right to alter without notice the specification or any conditions of supply for product or service.



677 EMC series



de-rating information

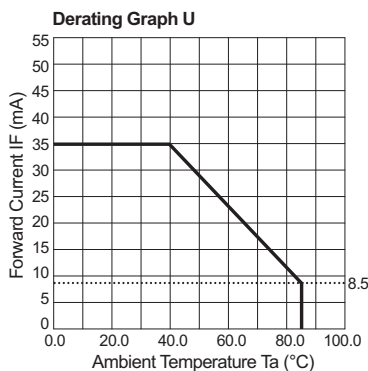
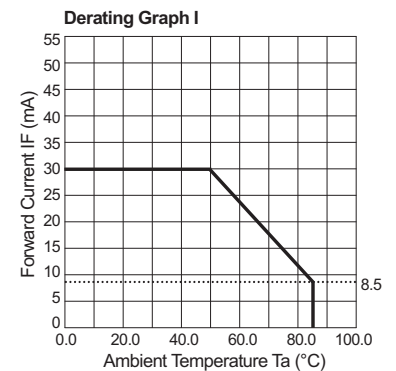
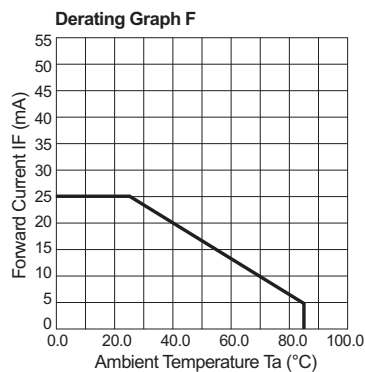
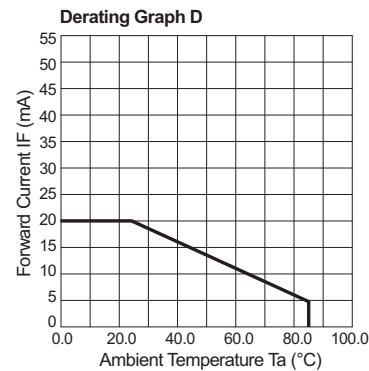

also available

Part numbers also available in the 677 series:

Part Number	Colour	Voltage Vopr	Part Number	Colour	Voltage Vopr	Part Number	Colour	Voltage Vopr
677-501-00-50	Red	-	677-501-75-50	Red	110 Vac 50 Hz	677-521-23	Yellow	28 Vdc
677-501-04	Red	20 mA dc	677-501-76-50	Red	230 Vac 50 Hz	677-521-23-15	Yellow	28 Vdc
677-501-04-51	Red	20 mA dc	677-501-86	Red	115 Vac 60 Hz	677-521-23-19	Yellow	28 Vdc
677-501-20	Red	5/6 Vdc	677-501-86-15	Red	115 Vac 60 Hz	677-521-24	Yellow	48 Vdc
677-501-20-53	Red	5/6 Vdc	677-503-23	Red	28 Vdc			
677-501-21	Red	12 Vdc	677-506-21	Orange	12 Vdc			
677-501-21-15	Red	12 Vdc	677-512-04	Green	20 mA dc			
677-501-21-19	Red	12 Vdc	677-512-23	Green	28 Vdc			
677-501-22	Red	24 Vdc	677-521-04	Yellow	20 mA dc			
677-501-23	Red	28 Vdc	677-521-04-50	Yellow	20 mA dc			
677-501-23-15	Red	28 Vdc	677-521-20	Yellow	5/6 Vdc			
677-501-23-19	Red	28 Vdc	677-521-21	Yellow	12 Vdc			
677-501-24	Red	48 Vdc	677-521-21-15	Yellow	12 Vdc			
677-501-46	Red	35 Vdc	677-521-21-19	Yellow	12 Vdc			
677-501-48-50	Red	60 Vdc	677-521-22	Yellow	24 Vdc			
677-501-75-15	Red	110 Vac 50 Hz	677-521-22-50	Yellow	24 Vdc			

The products listed here illustrate all of the options available to order. These products may have custom modifications that alter their operation beyond the generic information contained within this datasheet. Please contact sales for further information.

* = These products do not contain integral resistors

to order

to order please contact us on: t: +44 (0)1229 582 430 f: +44 (0)1229 585 155
e: sales@marl.co.uk w: www.leds.co.uk

© marl international limited technical documentation has been designed by marl international limited for the intention of providing information, which must not be copied or released to a third party without prior written consent from marl international limited. the information provided does not constitute part of any order or contract and should not be regarded as a representation relating to either products or service. no responsibility can be assumed for inaccuracies or printing errors. marl international limited reserve the right to alter without notice the specification or any conditions of supply for product or service.



677 EMC series



also available continued

Part Number	Colour	Voltage Vopr
677-523-22	Red	24 Vdc
677-523-23	Red	28 Vdc
677-524-21	Yellow	12 Vdc
677-524-22	Yellow	24 Vdc
677-525-22	Green	24 Vdc
677-525-23	Green	28 Vdc
677-530-23-50	Red/Green	28 Vdc
677-532-00-50	Green	100-265 Vac
677-532-00-51	Green	-
677-532-00-52	Green	-
677-532-04	Green	20 mA dc
677-532-20	Green	5/6 Vdc
677-532-20-19	Green	5/6 Vdc
677-532-21	Green	12 Vdc
677-532-21-15	Green	12 Vdc
677-532-21-19	Green	12 Vdc
677-532-22	Green	24 Vdc
677-532-22-50	Green	24 Vdc
677-532-23	Green	28 Vdc
677-532-23-05	Green	28 Vdc
677-532-23-15	Green	28 Vdc
677-532-23-19	Green	28 Vdc
677-532-23-50	Green	28 Vdc
677-532-23-54	Green	28 Vdc
677-532-24	Green	48 Vdc
677-532-46	Green	35 Vdc
677-532-48	Green	60 Vdc
677-532-48-50	Green	60 Vdc
677-532-75-19	Green	110 Vac 50 Hz
677-532-75-50	Green	110 Vac 50 Hz
677-532-75-51	Green	110 Vac 50 Hz
677-532-86	Green	115 Vac 60 Hz
677-532-86-15	Green	115 Vac 60 Hz
677-535-04-15	Red/Green	20 mA dc
677-540-23	Red	28 Vdc
677-590-22	Red	24 Vdc
677-930-20	Blue	5/6 Vdc
677-930-21	Blue	12 Vdc
677-930-21-19	Blue	12 Vdc
677-930-22	Blue	24 Vdc
677-930-23	Blue	28 Vdc
677-997-20	White	5/6 Vdc
677-997-21	White	12 Vdc
677-997-21-55	White	12 Vdc
677-997-22	White	24 Vdc
677-997-23	White	28 Vdc
677-997-23-15	White	28 Vdc
677-997-23-55	White	28 Vdc
677-997-75-15	White	110 Vac 50 Hz
677-997-75-19	White	110 Vac 50 Hz
677-997-75-50	White	110 Vac 50 Hz
677-997-86	White	115 Vac 60 Hz

to order

to order please contact us on: t: +44 (0)1229 582 430 f: +44 (0)1229 585 155
e: sales@marl.co.uk w: www.leds.co.uk

© marl international limited technical documentation has been designed by marl international limited for the intention of providing information, which must not be copied or released to a third party without prior written consent from marl international limited. the information provided does not constitute part of any order or contract and should not be regarded as a representation relating to either products or service. no responsibility can be assumed for inaccuracies or printing errors. marl international limited reserve the right to alter without notice the specification or any conditions of supply for product or service.



677 EMC series



design considerations

Electro-Static Discharge (ESD)

Build up of electro-static discharge occurs in many situations involving people moving and handling products. The range of possible situations is very diverse but voltage levels as high as several thousand volts can and do arise in many individual situations. When an operator charged up to these levels handles a static sensitive device, there is a very probable likelihood that the device will be irreversibly damaged. It is essential that precautions are taken at all stages during manufacture and assembly of these products. Although LEDs were never considered to be static sensitive devices, changes in manufacturing technology and materials used to produce higher intensity products over a large range of the wavelength spectrum have changed this. Marl has an approved system of ESD control from goods in, through production and into final packing and despatch. Marl recommend all users of LED based products follow the guidelines of BS 100015.

Power De-Rating

The forward voltage/ current value of an LED is dependant upon the ambient temperature of the environment in which it is operated. Therefore, care must be taken to operate the LED at the correct voltage/ current values, depending upon the ambient temperature. Consequently, a recommendation regarding operating voltages and currents is given in order to address these temperature effects. This recommendation is termed 'de-rating'. It is usual for forward voltages and currents to be specified for ambient temperature of 25°C. However, because the values of these qualities vary with temperature, please refer to the de-rating graphs for correct operation. Marl accept no liability for any product that is operated higher than the stated voltage.

to order

**to order please contact us on: t: +44 (0)1229 582 430 f: +44 (0)1229 585 155
e: sales@marl.co.uk w: www.leds.co.uk**

© marl international limited technical documentation has been designed by marl international limited for the intention of providing information, which must not be copied or released to a third party without prior written consent from marl international limited. the information provided does not constitute part of any order or contract and should not be regarded as a representation relating to either products or service. no responsibility can be assumed for inaccuracies or printing errors. marl international limited reserve the right to alter without notice the specification or any conditions of supply for product or service.

