

# Nuvoton Touch Key Series

## NT1160

### Datasheet

*The information described in this document is the exclusive intellectual property of Nuvoton Technology Corporation and shall not be reproduced without permission from Nuvoton.*

*Nuvoton is providing this document only for reference purposes of NuMicro microcontroller based system design. Nuvoton assumes no responsibility for errors or omissions.*

*All data and specifications are subject to change without notice.*

For additional information or questions, please contact: Nuvoton Technology Corporation.

[www.nuvoton.com](http://www.nuvoton.com)

**Table of Contents**

1 General Description.....4

2 Features .....5

3 Pin Diagram .....6

4 Capacitive Touch Key .....7

    4.1 Input Circuit ..... 7

    4.2 Sensor Pad and Ground for PCB Layout ..... 8

    4.3 Sensor Pad Size ..... 8

5 I<sup>2</sup>C Interface ..... 10

    5.1 Byte-Write .....10

    5.2 Random-Read .....10

    5.3 Continuous-Read .....11

    5.4 I<sup>2</sup>C Circuit .....11

6 I<sup>2</sup>C Data Definition ..... 12

    6.1 Memory Address .....12

    6.2 Address 0x00: Product No.....13

    6.3 Address 0x01: Button No. ....13

    6.4 Address 0x02: Version No.....13

    6.5 Address 0x03: I<sup>2</sup>C Device Address .....14

    6.6 Address 0x04: System Control Bits .....14

    6.7 Address 0x06: Output Mode Settings .....14

    6.8 Address 0x07: Sense Pin Enable 1 .....15

    6.9 Address 0x08: Sense Pin Enable 2 .....15

    6.10 Address 0x0C: De-Bounce .....15

    6.11 Address 0x0E: Sensor Cycle .....15

    6.12 Address 0x0F: Calibration Delay .....15

    6.13 Address 0x10: Status.....15

    6.14 Address 0x11: Key Status 1.....15

    6.15 Address 0x12: Key Status 2.....16

    6.16 Address 0x15: 7 Segment LED Display .....16

    6.17 Address 0x20~0x2F: Trigger Level .....16

    6.18 Address 0x40~0x5F: Sensor Value.....16

7 Reference Schematic..... 18

8 Electrical Characteristics ..... 19

8.1 Absolute Maximum Ratings ..... 19

8.2 DC Electrical Characteristics ..... 19

9 Package Dimension ..... 20

9.1 TSSOP20 – 4.4X6.5mm ..... 20

10 REVISION HISTORY ..... 21

## 1 GENERAL DESCRIPTION

The Nuvoton touch key series, NT1160, provides an easy-to-implement touch key interface solution and supports configurable 16 touch button applications, 3-channel LED output, and multi-key input mode configuration, such as single touch key, multi-keys and Toggle function to enable the shortest development cycle. Through the I<sup>2</sup>C bus implemented by an external device, the NT1160 can be controlled to handle chip performance precisely.

There is nearly no special requirement for application board circuit design, and no need to design special ground net or other protections for the key pad. The NT1160 provides excellent anti-static capability and immunity to EFT. It also supports outstanding immunity to EMI from mobile phone or walkie-talkie applications. That is to say, the NT1160 provides a comprehensive response to a variety of applications.

The NT1160 is suitable for a wide range of applications, such as audio panel, telephone keyboard, instrument control panel, washer control panel, access control system control panel, household appliances and various small appliances (cooker, disinfection cabinet, microwave, etc.). Almost all applications related to the control panel key operation can be used.

## 2 FEATURES

- Support 16 capacitive touch keys
- Support 3 LED driver
- Output modes:
  - LED display
  - I<sup>2</sup>C
- Water resistant or water-droplet operation
  - Water-droplet operation without action errors
  - Key lock function
- Resist electromagnetic interference
  - Resistance to electromagnetic radiation of mobile phones
- Multiple touch key output selection
  - Single touch key/ multi-keys function selectable
  - Key lock function
  - Prompt output function selectable
- I<sup>2</sup>C parameter settings
  - Touch key trigger level for each key
  - Touch key de-bounce for each key
  - Auto calibration interval
- Operating voltage: 2.4V~5.5V
- Operating current: 1.8mA~2.3mA
- Operating temperature: -40°C ~+85°C
- Touch key response time: 51 ms

### 3 PIN DIAGRAM

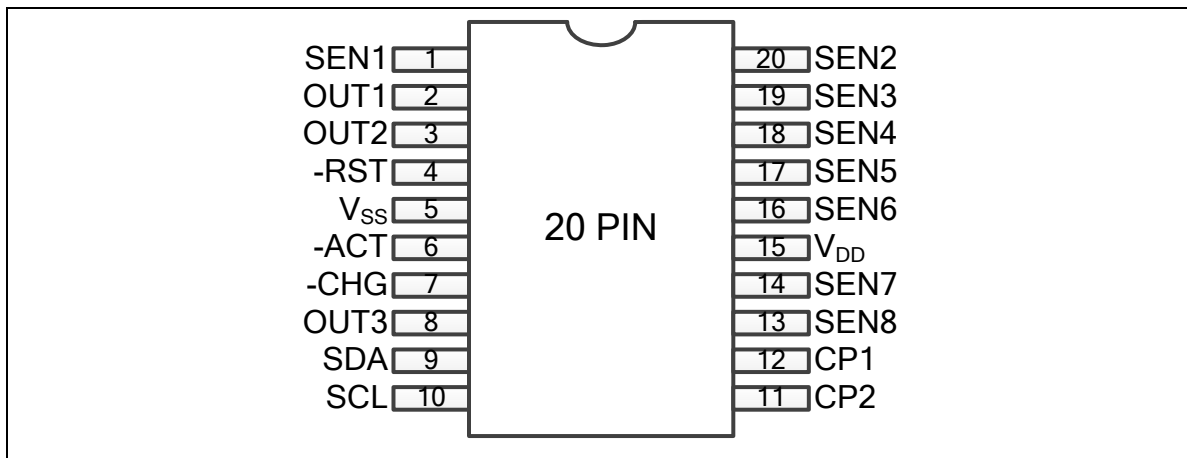

Figure 3-1 TSSOP20 Pin Diagram

No.	Pin Name	Description
1	SEN1	Touch key-1 input pin.
2	OUT1	LED output pin 1
3	OUT2	LED output pin 2
4	-RST	IC reset pin.
5	V <sub>SS</sub>	Ground pin.
6	-ACT	Touch key active indicator
7	-CHG	Touch key status change indicator
8	OUT3	LED output pin 3
9	SDA	Data pin of I <sup>2</sup> C bus
10	SCL	Clock pin of I <sup>2</sup> C bus
11	CP2	Touch key driving signal 2
12	CP1	Touch key driving signal 1
13	SEN8	Touch key-8 input pin.
14	SEN7	Touch key-7 input pin.
15	V <sub>DD</sub>	Power supply pin.
16	SEN6	Touch key-6 input pin.
17	SEN5	Touch key-5 input pin.
18	SEN4	Touch key-4 input pin.
19	SEN3	Touch key-3 input pin.
20	SEN2	Touch key-2 input pin.

Table 3-1 Pin Description

## 4 CAPACITIVE TOUCH KEY

### 4.1 Input Circuit

Each capacitive touch key needs to be connected with one resistor as shown in Figure 4-1. It is strongly recommended that the resistor value is 390 kΩ and the capacitor value is 4.7pF. At the same time, all the resistors need to be kept as close to sensor pad as possible during PCB layout.

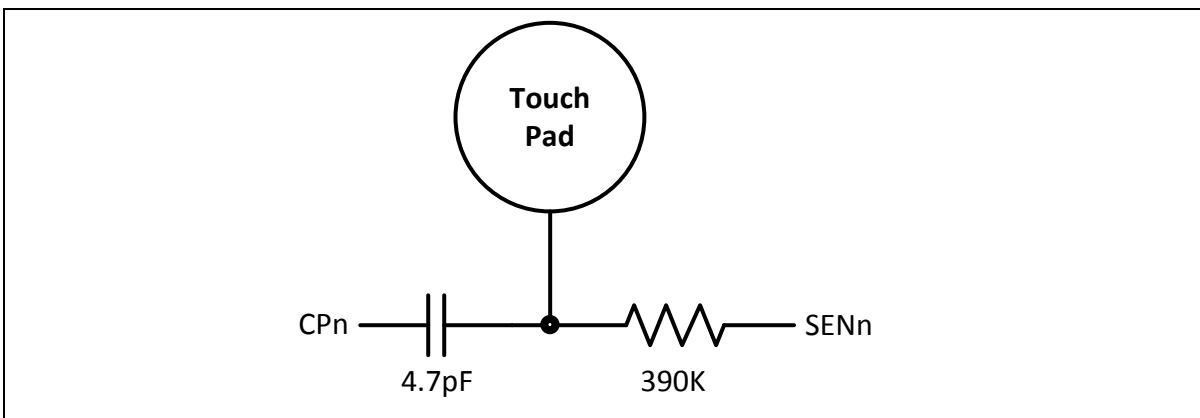

Figure 4-1 Touch Key Reference Circuit

There are two touch key driving signals (CPn) for NT1160 to operate matrix scan. One SIN pin can distinguish two touch keys through the driving signal as shown in Figure 4-2.

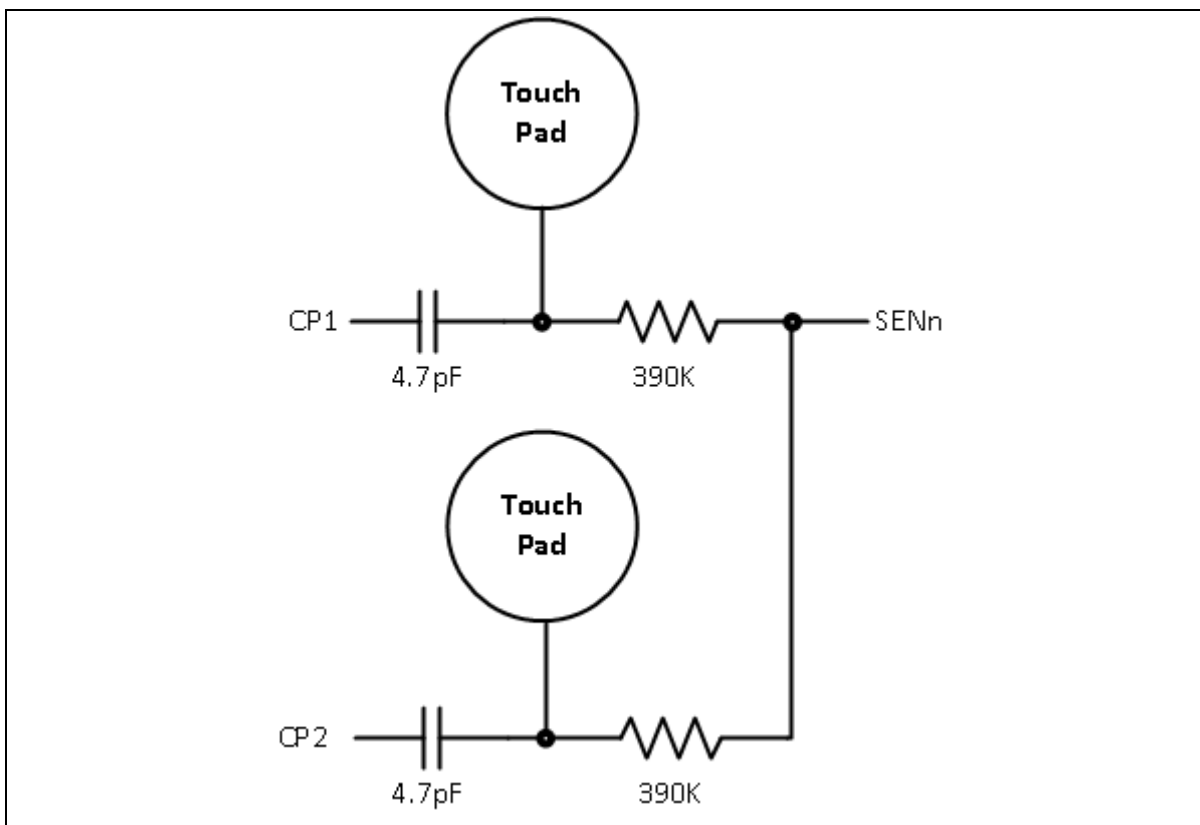

Figure 4-2 Scanning Touch Key Reference Circuit

### 4.2 Sensor Pad and Ground for PCB Layout

The size of sensor pad, using circular shape with diameter equal or greater than 8mm is recommended. Actually, sensor pad could be any kinds of shape, but fulfilling finger size is suitable. Extra ground-net around sensor pads is not needed for PCB artwork. However, ground-net along sensor pad to chip is alternative. Figure 4-3 shows that the PCB line width of sensor pad to chip should be 0.254mm (10mil) or less and to keep distance with ground at least 1mm. The other layer of PCB could implement ground-net for PCB artwork to block noise interfering with signal line. All the subsidiary components need to be kept as close to sensor pad as possible at PCB layout. Meanwhile, the touch key chip (NT1160) and touch pad located on the same PCB board would be better.

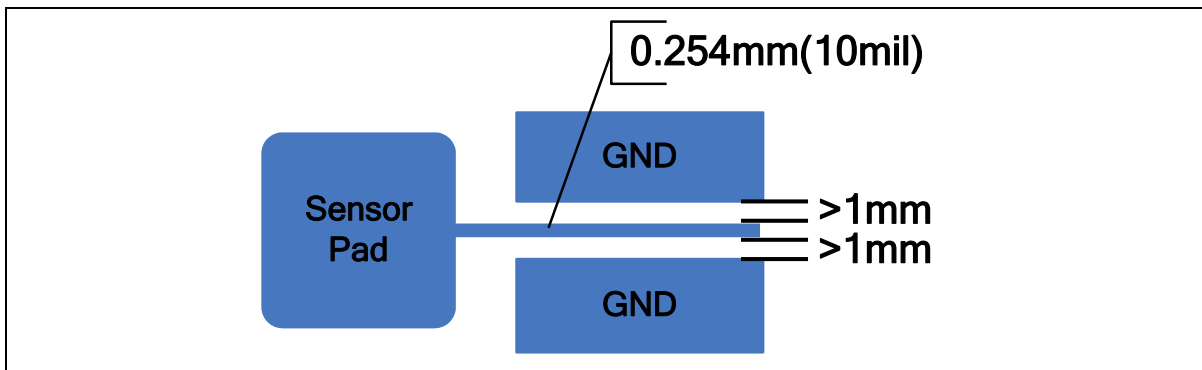

Figure 4-3 Sensor Pad and Ground-Net

As shown in Figure 4-4, a spring attached to the metal-panel can be used as a sensor pad. It is recommended that the metal-panel (ring) should be adhered to the inside of cover to be an effective sensing area. If user wants to add a LED in the middle of sensor pad, the measure of sensor area should be increased to compensate the hollowing part and keeping the same sensitivity.



Figure 4-4 Spring with Solid Metal Plane/Ring

### 4.3 Sensor Pad Size

The size of sensor pad plays a significant role in determining the thickness of panel. The greater area of a sensor pad is, the deeper a touch signal could be detected. Table 4-1 shows the relationship between the pad size and panel thickness.

Size of Sensor Pad	Panel Thickness (Recommended Value)
--------------------	-------------------------------------

8 mm x 8 mm	2.0 mm
10 mm x 10 mm	3.0 mm
15 mm x 15 mm	4.5 mm
20 mm x 20 mm	6.0 mm

Table 4-1 Sensor Pad and Corresponding Panel Thickness

## 5 I<sup>2</sup>C INTERFACE

The maximum speed of I<sup>2</sup>C serial interface could be up to 400Kbps and it will not send any signal in an active way to main controller since it is I<sup>2</sup>C slave. The I<sup>2</sup>C interface is not working in normal operation time. To enter I<sup>2</sup>C serial mode, user must connect V<sub>DD</sub> to SEL pin and then make chip power-on. User could easily set the touch related parameter and adjust the sensitivity by using the I<sup>2</sup>C interface.

The I<sup>2</sup>C transmission provides three modes: byte-write, random-read and continuous-read.

### 5.1 Byte-Write

The data protocol includes 3 bytes from master writing data to slave. The first byte for Device address, the second byte for Memory address and the third byte is for the write data. Figure 5-1 shows the detail about byte-write action.

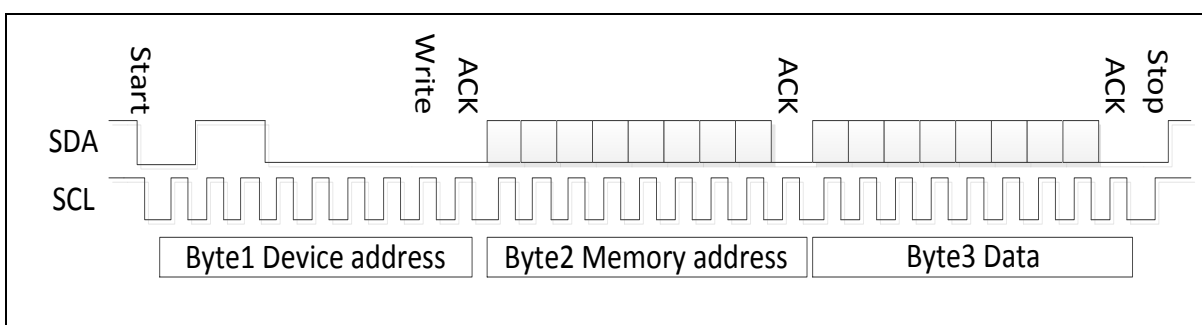

Figure 5-1 Byte-write Mode

In normal times, SDA and SCL will be kept as logic 1. For the start signal, SDA will change to logic 0 first then SCL to logic 0 as well. When transmitting, data is prepared on SDA signal and then SCL will change to logic 1. Slave reads the byte data based on the rising edge of SCL signal. Slave will send logic 0 on the 9th clock signal to indicate receiving the byte data. For the stop signal, master device will change SCL to logic 1 and then SDA to 1, when the transmission of 3 bytes of information is finished.

### 5.2 Random-Read

This is a 4-byte data combination when Master reads Slave. Figure 5-2 shows that the first byte is used as device address and write-status; the second byte is used as memory address; the third byte is used as device address and read-status and the fourth byte is used as Slave output data with Master keeping sending the SCL clock signal.

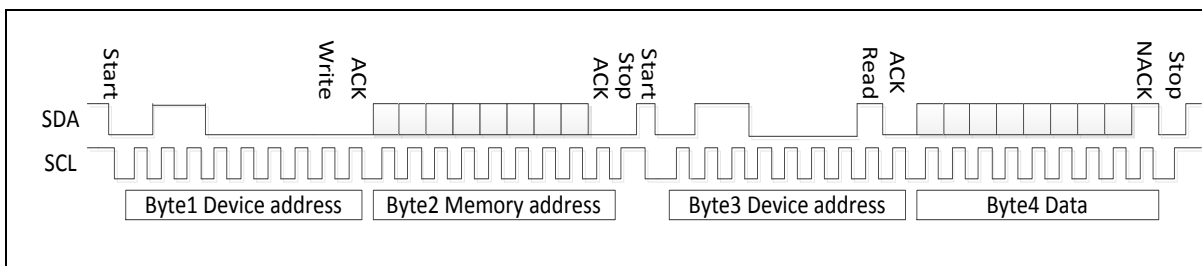

Figure 5-2 Random-Read Mode

After the 2nd byte data transmission is complete, the start signal is needed before sending the next 3rd byte data. The SCL signal will change to logic 0 when 3rd byte data transmission is done. SCL signal will be released till 4<sup>th</sup> output data is ready. The first host could send logic 1 on SCL and monitor SCL changing to logic 1 to receive 1<sup>st</sup> bit. Note that Master should send a logic 1, NACK signal, on the 9th clock signal of the 4th byte.

### 5.3 Continuous-Read

This is a 4-byte data combination when Master continually reads Slave. Figure 5-3 shows that the first byte as device address and write-status; the second byte as memory address; the third byte as device address and read-status. From the fourth byte, Slave will keep output data with Master keeping sending ACK and SCL clock signal. The memory address will be automatically increased.

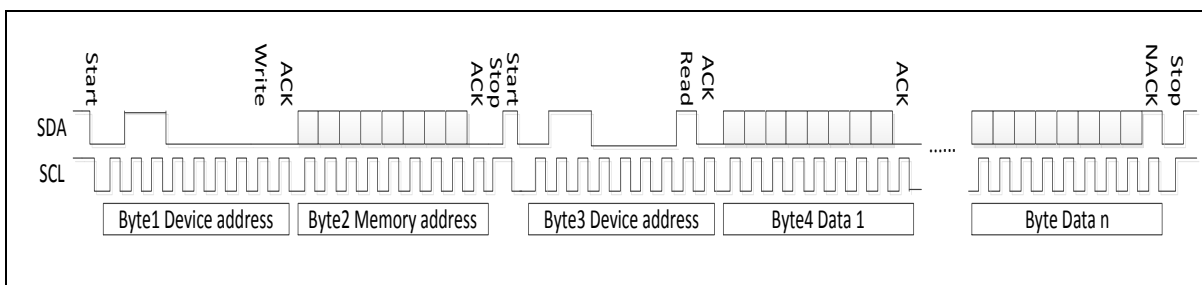

Figure 5-3 Continuous-Read Mode

### 5.4 I<sup>2</sup>C Circuit

The I<sup>2</sup>C pins are SDA and SCL with Open-Drain mode which requires pull-high resistor on the I<sup>2</sup>C bus.

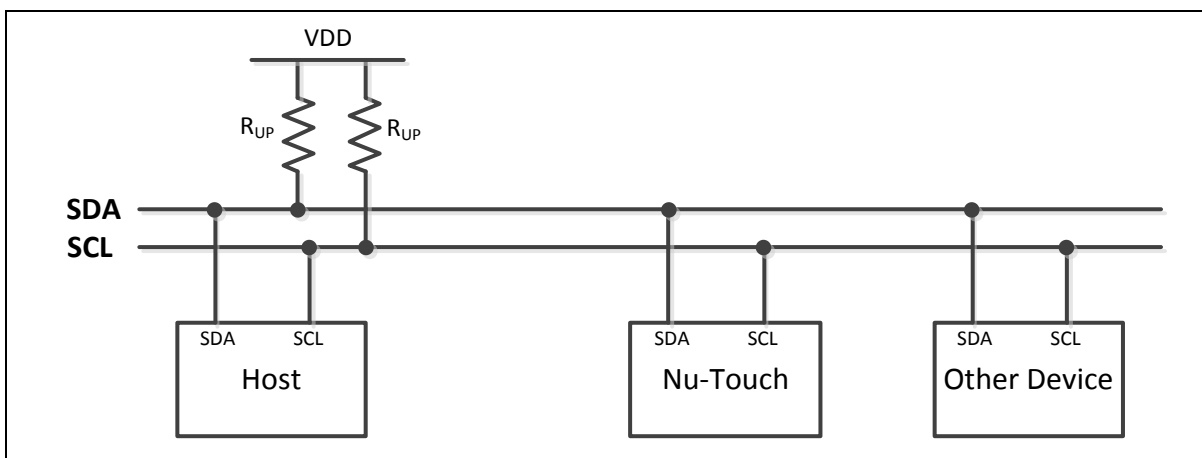

Figure 5-4 I<sup>2</sup>C Bus Connection

## 6 I<sup>2</sup>C DATA DEFINITION

### 6.1 Memory Address

Table 6-1 shows the memory address of I<sup>2</sup>C starting from 0x00~0x4F with specific function on each address.

**R:** Read only, **R/W:** Read / Write, **(B)R:** Must be set "Build" bit, and user can read only.

**(B)R/W:** Must be set to "Build" bit, and user can read and write.

Address	R/W	Description	Default																
0x00	R	Product number	0x3E																
0x01	R	Shows how many buttons supported.	0x16																
0x02	R	Version number	0x31																
0x03	R/W	I <sup>2</sup> C Device address	0x60																
		<table border="1"> <tr> <td>Bit7</td> <td>Bit6</td> <td>Bit5</td> <td>Bit4</td> <td>Bit3</td> <td>Bit2</td> <td>Bit1</td> <td>Bit0</td> </tr> <tr> <td>A7</td> <td>A6</td> <td>A5</td> <td>A4</td> <td>A3</td> <td>A2</td> <td>A1</td> <td>0</td> </tr> </table>		Bit7	Bit6	Bit5	Bit4	Bit3	Bit2	Bit1	Bit0	A7	A6	A5	A4	A3	A2	A1	0
		Bit7		Bit6	Bit5	Bit4	Bit3	Bit2	Bit1	Bit0									
A7	A6	A5	A4	A3	A2	A1	0												
0x04	R/W	System control	0x08																
		<table border="1"> <tr> <td>Bit7</td> <td>Bit6</td> <td>Bit5</td> <td>Bit4</td> <td>Bit3</td> <td>Bit2</td> <td>Bit1</td> <td>Bit0</td> </tr> <tr> <td>Reset</td> <td>X</td> <td>X</td> <td>X</td> <td>Auto</td> <td>Calibrate</td> <td>X</td> <td>Build</td> </tr> </table>		Bit7	Bit6	Bit5	Bit4	Bit3	Bit2	Bit1	Bit0	Reset	X	X	X	Auto	Calibrate	X	Build
		Bit7		Bit6	Bit5	Bit4	Bit3	Bit2	Bit1	Bit0									
Reset	X	X	X	Auto	Calibrate	X	Build												
0x06	R/W	Output mode	0x04																
		<table border="1"> <tr> <td>Bit7</td> <td>Bit6</td> <td>Bit5</td> <td>Bit4</td> <td>Bit3</td> <td>Bit2</td> <td>Bit1</td> <td>Bit0</td> </tr> <tr> <td>Multi</td> <td>X</td> <td>X</td> <td>X</td> <td>Lock</td> <td>En-Any</td> <td>0</td> <td>X</td> </tr> </table>		Bit7	Bit6	Bit5	Bit4	Bit3	Bit2	Bit1	Bit0	Multi	X	X	X	Lock	En-Any	0	X
		Bit7		Bit6	Bit5	Bit4	Bit3	Bit2	Bit1	Bit0									
Multi	X	X	X	Lock	En-Any	0	X												
0x07	(B)R/W	Sense pin Enable 1	0xFF																
		<table border="1"> <tr> <td>Bit7</td> <td>Bit6</td> <td>Bit5</td> <td>Bit4</td> <td>Bit3</td> <td>Bit2</td> <td>Bit1</td> <td>Bit0</td> </tr> <tr> <td>Sen8</td> <td>Sen7</td> <td>Sen6</td> <td>Sen5</td> <td>Sen4</td> <td>Sen3</td> <td>Sen2</td> <td>Sen1</td> </tr> </table>		Bit7	Bit6	Bit5	Bit4	Bit3	Bit2	Bit1	Bit0	Sen8	Sen7	Sen6	Sen5	Sen4	Sen3	Sen2	Sen1
		Bit7		Bit6	Bit5	Bit4	Bit3	Bit2	Bit1	Bit0									
Sen8	Sen7	Sen6	Sen5	Sen4	Sen3	Sen2	Sen1												
0x08	(B)R/W	Sense pin Enable 2 °	0xFF																
		<table border="1"> <tr> <td>Bit7</td> <td>Bit6</td> <td>Bit5</td> <td>Bit4</td> <td>Bit3</td> <td>Bit2</td> <td>Bit1</td> <td>Bit0</td> </tr> <tr> <td>Sen16</td> <td>Sen15</td> <td>Sen14</td> <td>Sen13</td> <td>Sen12</td> <td>Sen11</td> <td>Sen10</td> <td>Sen9</td> </tr> </table>		Bit7	Bit6	Bit5	Bit4	Bit3	Bit2	Bit1	Bit0	Sen16	Sen15	Sen14	Sen13	Sen12	Sen11	Sen10	Sen9
		Bit7		Bit6	Bit5	Bit4	Bit3	Bit2	Bit1	Bit0									
Sen16	Sen15	Sen14	Sen13	Sen12	Sen11	Sen10	Sen9												
0x0C	(B)R/W	De-Bounce (Range: 1~7)	0x03																
0x0E	(B)R/W	Sensor Cycle (Range: 3~15)	0x07																
0x0F	(B)R/W	Calibration Delay (Range: 7~63)	0x32																
0x10	R	Status	0x00																
		<table border="1"> <tr> <td>Bit7</td> <td>Bit6</td> <td>Bit5</td> <td>Bit4</td> <td>Bit3</td> <td>Bit2</td> <td>Bit1</td> <td>Bit0</td> </tr> <tr> <td>Any-Act</td> <td>B-Change</td> <td>0</td> <td>0</td> <td>0</td> <td>0</td> <td>0</td> <td>0</td> </tr> </table>		Bit7	Bit6	Bit5	Bit4	Bit3	Bit2	Bit1	Bit0	Any-Act	B-Change	0	0	0	0	0	0
		Bit7		Bit6	Bit5	Bit4	Bit3	Bit2	Bit1	Bit0									
Any-Act	B-Change	0	0	0	0	0	0												

0x11	R	Key Status 1								0x00
		Bit7	Bit6	Bit5	Bit4	Bit3	Bit2	Bit1	Bit0	
		Sen8	Sen7	Sen6	Sen5	Sen4	Sen3	Sen2	Sen1	
0x12	R	Key Status 2								0x00
		Bit7	Bit6	Bit5	Bit4	Bit3	Bit2	Bit1	Bit0	
		Sen16	Sen15	Sen14	Sen13	Sen12	Sen11	Sen10	Sen9	
0x15	R/W	LED Control								0x00
		Bit7	Bit6	Bit5	Bit4	Bit3	Bit2	Bit1	Bit0	
		0	0	0	0	0	OUT3	OUT2	OUT1	
0x20~0x2 F	(B)R/W	Trigger Level (Range: 3~63)								0x12
		0x20	0x21	0x22	0x23	0x24	0x25	0x26	0x27	
		Sen1	Sen2	Sen3	Sen4	Sen5	Sen6	Sen7	Sen8	
		0x28	0x29	0x2A	0x2B	0x2C	0x2D	0x2E	0x2F	
		Sen9	Sen10	Sen11	Sen12	Sen13	Sen14	Sen15	Sen16	
0x40~0x5F	(B)R	Sensor Value								0x0000
		0x40	0x41	0x42	0x43	0x44	0x45	0x46	0x47	
		Sen1		Sen2		Sen3		Sen4		
		0x48	0x49	0x4A	0x4B	0x4C	0x4D	0x4E	0x4F	
		Sen5		Sen6		Sen7		Sen8		
		0x50	0x51	0x52	0x53	0x54	0x55	0x56	0x57	
		Sen9		Sen10		Sen11		Sen12		
		0x58	0x59	0x5A	0x5B	0x5C	0x5D	0x5E	0x5F	
		Sen13		Sen14		Sen15		Sen16		

Table 6-1 I<sup>2</sup>C Memory Address Definition and Description

**6.2 Address 0x00: Product No.**

For product identification use.

**6.3 Address 0x01: Button No.**

For product identification use.

**6.4 Address 0x02: Version No.**

For Product identification use.

### 6.5 Address 0x03: I<sup>2</sup>C Device Address

The default address is 0x60, including read/write 8-bit address. The device address could be changed by the I<sup>2</sup>C interface. When changing the device address, the latest device address must be used in the next read/write action.

### 6.6 Address 0x04: System Control Bits

Bit7	Bit6	Bit5	Bit4	Bit3	Bit2	Bit1	Bit0
Reset	X	X	X	Auto	Calibrate	X	Build

**Reset:**                   **Software reset.**

Chip could be reset by writing “1” to become default value. This bit will be automatically changed back to “0” when chip reset is done.

**Auto:**                   **Auto Calibration.**

Write “1” to this bit and chip will automatically refer the value in address “0x0F” to execute new calibration delay time function.

**Calibrate:**           **Calibration enabled.**

User could set this bit to enable calibration procedure and this bit will return to “0” when finishing the calibration. This bit is valid when “Auto” bit is “0”.

**Build:**                   **Test mode.**

1 = Read related sensor parameter and data to provide test and analysis function.

0 = Hide some parameter which has nothing to do with operation action to prevent parameter being changed accidentally.

### 6.7 Address 0x06: Output Mode Settings

Bit7	Bit6	Bit5	Bit4	Bit3	Bit2	Bit1	Bit0
Multi	0	0	0	Lock	En-Any	0	0

**Multi:**                   **Multi-key output.**

1 = Output multi-key status simultaneously

0 = Output the key status with greatest signal

**Lock:**                   **Lock.**

1 = If two or more keys are triggered, all output will be locked and no any output signal happened.

**En-Any:**               **Enable -Act pin.**

1 = Enable -Act pin function. Any pressed key will make the -Act pin output low level signal. The -Act pin will return to high level when no key is pressed.

**6.8 Address 0x07: Sense Pin Enable 1**

Bit7	Bit6	Bit5	Bit4	Bit3	Bit2	Bit1	Bit0
Sen8	Sen7	Sen6	Sen5	Sen4	Sen3	Sen2	Sen1

**Sen8~Sen1:**      **Enable Sense Pin.**  
 1 = Enable corresponding key  
 0 = Disable corresponding key

**6.9 Address 0x08: Sense Pin Enable 2**

Bit7	Bit6	Bit5	Bit4	Bit3	Bit2	Bit1	Bit0
Sen16	Sen15	Sen14	Sen13	Sen12	Sen11	Sen10	Sen9

**Sen16~Sen9:**      **Enable Sense Pin.**  
 1 = Enable corresponding key  
 0 = Disable corresponding key

**6.10 Address 0x0C: De-Bounce**

The value is from 1 to 7. Set this parameter to avoid key output bouncing. The key will react slower with less chance of bouncing if this value is set higher.

**6.11 Address 0x0E: Sensor Cycle**

The value is from 3 to 15. The captures data will be more stable and key react slower if this value is set higher.

**6.12 Address 0x0F: Calibration Delay**

The value is from 7 to 63. It defines how long the chip will do re-calibration process again.  
 This bit is valid if "Auto" bit is set to "1".

**6.13 Address 0x10: Status.**

Bit7	Bit6	Bit5	Bit4	Bit3	Bit2	Bit1	Bit0
Any-Act	B-Change	0	0	0	0	0	0

**Any-Act:**              This bit will be set to "1" if any key is pressed.  
 It will be cleared to "0" if all keys are released.

**B-Change:**            This bit will be set to "1" if any key status is changed.  
 It will be cleared to "0" if no key status is changed whether key is pressed or not.

**6.14 Address 0x11: Key Status 1**

Bit7	Bit6	Bit5	Bit4	Bit3	Bit2	Bit1	Bit0
Sen8	Sen7	Sen6	Sen5	Sen4	Sen3	Sen2	Sen1

**Sen8~Sen1:** 1 = Corresponding key is pressed.  
 0 = Corresponding key is released.  
 Reading status here will ignore the setting in Output mode.

**6.15 Address 0x12: Key Status 2**

Bit7	Bit6	Bit5	Bit4	Bit3	Bit2	Bit1	Bit0
Sen16	Sen15	Sen14	Sen13	Sen12	Sen11	Sen10	Sen9

**Sen16~Sen9:** 1 = Corresponding key is pressed.  
 0 = Corresponding key is released.  
 Reading status here will ignore the setting in Output mode.

**6.16 Address 0x15: 7 Segment LED Display**

Bit7	Bit6	Bit5	Bit4	Bit3	Bit2	Bit1	Bit0
0	0	0	0	0	OUT3	OUT2	OUT1

**OUT8~OUT1:** Corresponding to pin OUT3~OUT1.  
 1 = Pin output high.  
 0 = Pin output low.

**6.17 Address 0x20~0x2F: Trigger Level**

The value is from 3 to 63. This bit is to set trigger level individually to eliminate the sensitivity difference on each touch key sensor. The lower value user set will get higher sensitivity but lower stability.

<b>Address</b>	<b>0x20</b>	<b>0x21</b>	<b>0x22</b>	<b>0x23</b>	<b>0x24</b>	<b>0x25</b>	<b>0x26</b>	<b>0x27</b>
Sensor	Sen1	Sen2	Sen3	Sen4	Sen5	Sen6	Sen7	Sen8
<b>Address</b>	<b>0x28</b>	<b>0x29</b>	<b>0x2A</b>	<b>0x2B</b>	<b>0x2C</b>	<b>0x2D</b>	<b>0x2E</b>	<b>0x2F</b>
Sensor	Sen9	Sen10	Sen11	Sen12	Sen13	Sen14	Sen15	Sen16

**6.18 Address 0x40~0x5F: Sensor Value**

The value shows the reading sampling result which is from 0 to 1023. The data format is MSB first, then LSB.

<b>Address</b>	<b>0x40</b>	<b>0x41</b>	<b>0x42</b>	<b>0x43</b>	<b>0x44</b>	<b>0x45</b>	<b>0x46</b>	<b>0x47</b>
Sensor	Sen1-Hi Sen1-Lo	Sen1-Hi Sen1-Lo	Sen2-Hi Sen2-Lo	Sen2-Hi Sen2-Lo	Sen3-Hi Sen3-Lo	Sen3-Hi Sen3-Lo	Sen4-Hi Sen4-Lo	Sen4-Hi Sen4-Lo
<b>Address</b>	<b>0x48</b>	<b>0x49</b>	<b>0x4A</b>	<b>0x4B</b>	<b>0x4C</b>	<b>0x4D</b>	<b>0x4E</b>	<b>0x4F</b>
Sensor	Sen5-Hi Sen5-Lo	Sen5-Hi Sen5-Lo	Sen6-Hi Sen6-Lo	Sen6-Hi Sen6-Lo	Sen7-Hi Sen7-Lo	Sen7-Hi Sen7-Lo	Sen8-Hi Sen8-Lo	Sen8-Hi Sen8-Lo

<b>Address</b>	<b>0x50</b>	<b>0x51</b>	<b>0x52</b>	<b>0x53</b>	<b>0x54</b>	<b>0x55</b>	<b>0x56</b>	<b>0x57</b>
Sensor	Sen9-Hi	Sen9-Lo	Sen10-Hi	Sen10-Lo	Sen11-Hi	Sen11-Lo	Sen12-Hi	Sen12-Lo
<b>Address</b>	<b>0x58</b>	<b>0x59</b>	<b>0x5A</b>	<b>0x5B</b>	<b>0x5C</b>	<b>0x5D</b>	<b>0x5E</b>	<b>0x5F</b>
Sensor	Sen13-Hi	Sen13-Lo	Sen14-Hi	Sen14-Lo	Sen15-Hi	Sen15-Lo	Sen16-Hi	Sen16-Lo

7 REFERENCE SCHEMATIC

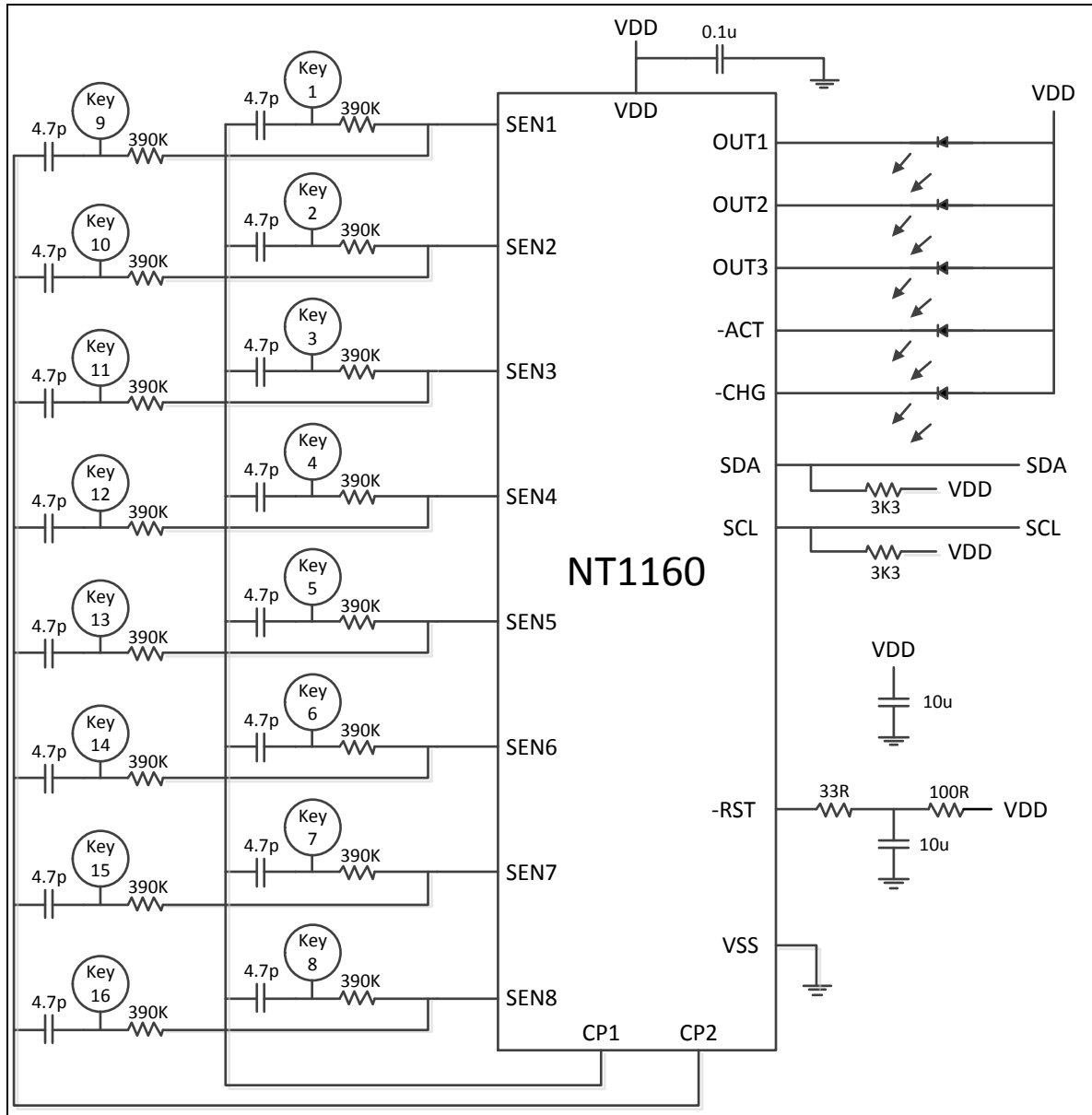

## 8 ELECTRICAL CHARACTERISTICS

### 8.1 Absolute Maximum Ratings

Parameter	Range	Unit
Operating Temperature	-40 to +85	°C
Storage Temperature	-55 to +150	°C
V <sub>DD</sub> to V <sub>SS</sub> voltage	-0.3 to +6.5	V
Other pin to V <sub>SS</sub> voltage	-0.3 to (V <sub>DD</sub> +0.3)	V

### 8.2 DC Electrical Characteristics

Parameter	Symbol	Condition	Min.	Typ.	Max.	Unit
Operating Voltage	V <sub>DD</sub>	---	2.4	-	5.5	V
Operating Current	I <sub>DD</sub>	V <sub>DD</sub> = 5V	-	2.30	-	mA
		V <sub>DD</sub> = 3V	-	1.93	-	mA
Input Low Voltage	V <sub>IL</sub>	2.4V < V <sub>DD</sub> < 5.5	-0.5	-	0.3V <sub>DD</sub>	V
Input High Voltage	V <sub>IH</sub>	2.4V < V <sub>DD</sub> < 5.5	0.7V <sub>DD</sub>	-	V <sub>DD</sub> +0.5	V
Output Low Voltage (GPIO)	V <sub>OL</sub>	V <sub>DD</sub> = 4.5V, I <sub>OL</sub> = 20mA	-	-	0.45	V
Output High Voltage	V <sub>OH</sub>	V <sub>DD</sub> = 4.5V, I <sub>OL</sub> = -28mA	2.4	—	—	V

9 PACKAGE DIMENSION

9.1 TSSOP20 – 4.4X6.5mm

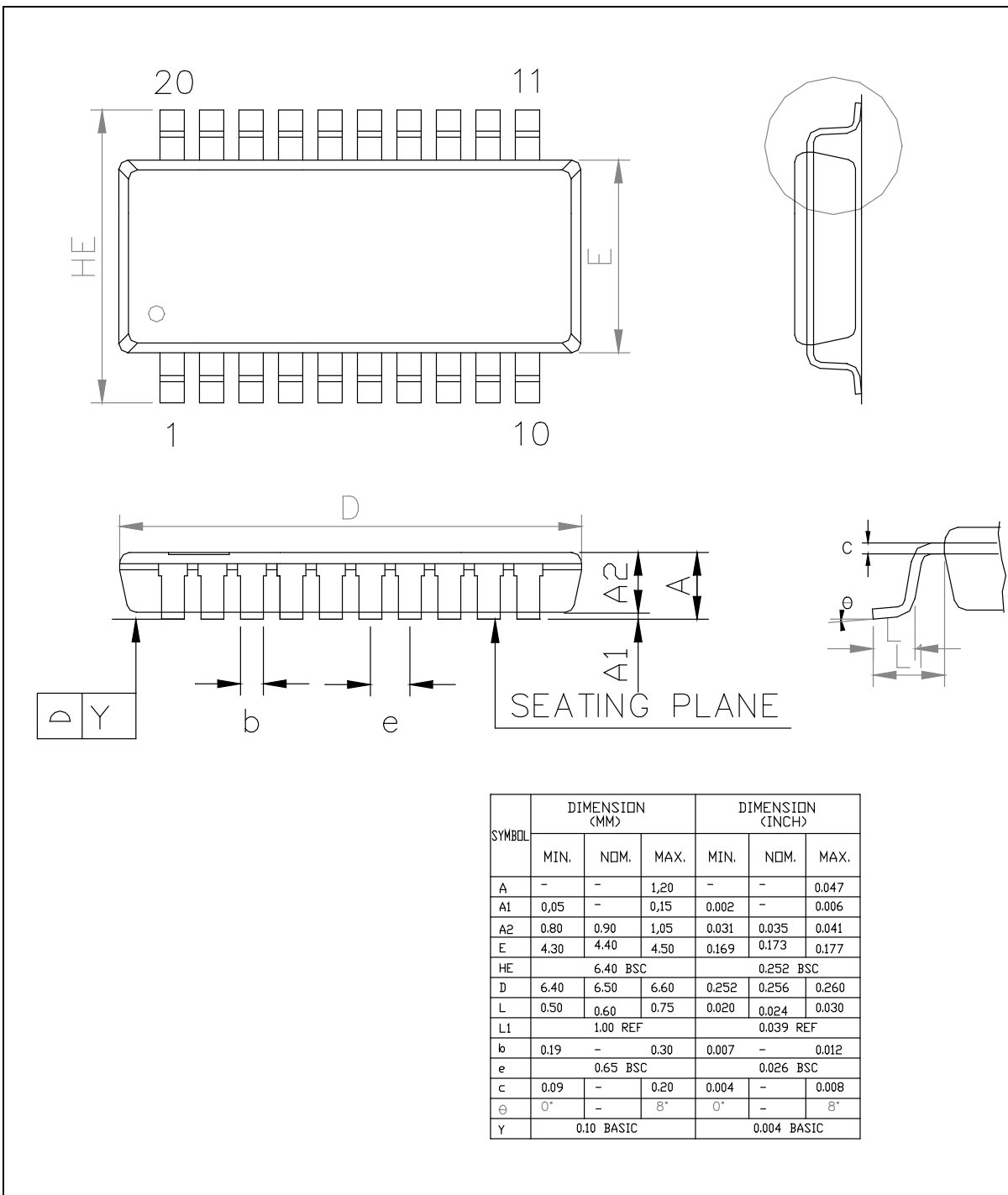

**10 REVISION HISTORY**

Date	Revision	Description
2016.03.12	1.00	Preliminary version

### Important Notice

**Nuvoton Products are neither intended nor warranted for usage in systems or equipment, any malfunction or failure of which may cause loss of human life, bodily injury or severe property damage. Such applications are deemed, "Insecure Usage".**

**Insecure usage includes, but is not limited to: equipment for surgical implementation, atomic energy control instruments, airplane or spaceship instruments, the control or operation of dynamic, brake or safety systems designed for vehicular use, traffic signal instruments, all types of safety devices, and other applications intended to support or sustain life.**

**All Insecure Usage shall be made at customer's risk, and in the event that third parties lay claims to Nuvoton as a result of customer's Insecure Usage, customer shall indemnify the damages and liabilities thus incurred by Nuvoton.**

---

*Please note that all data and specifications are subject to change without notice.  
All the trademarks of products and companies mentioned in this datasheet belong to their respective owners.*