



15600

CMOS IC

MELODY IC

DESCRIPTION

UTC **15600** Series is a CMOS IC circuits which contain a programmed mask ROM to generate chord music. The capacity of the ROM being used for storage of such music information is of 128 words and up to two numbers of music melodies under two different sound sources can be optioned for storage into it. Also, the total integration (for mask option) of the RC oscillation circuit is built in. Moreover, a small-sized package can be suitable for space –saving applications.

FEATURES

- * Range of operating voltage: 0.9~5.5V
- * Reference signal source frequency: 32.768KHZ,47.520KHZ(mask option selection)

* Options :

1. changing the melody midway during performance: Possible or not possible (mask option selection)
2. selection of the reference sound frequency: when selecting the signal source frequency of 32.768kHz, A4=440Hz(standard) or C4=256Hz when selecting the signal source frequency of 47.520kHz: A4=440Hz
3. Selection of performance sound range: when selecting the signal source frequency of
 - 32.768kHz, A4=440Hz: G6~C4 or G5~C3
 - 32.768kHz, A4=256Hz: C7~C4 or C6~C3
 - 47.520kHz, A4=440Hz: C7~C4 or C6~F3
4. Choices of the reference signal source: External clock input or integrated RC oscillator (using both of the integrated C and R) or integrated RC oscillation (using the integrated C only but the R is for external installation)

5. performance method choice :

- Level hold
- one shot C
- one shot A
- * Attenuation of sound: integrated envelope adding circuit
- * Loudspeaker drive: not equipping an amplifier(an extremely installed amplifier should be used)
- * Output Impedance :
 - Max: 222k
 - Min :68k

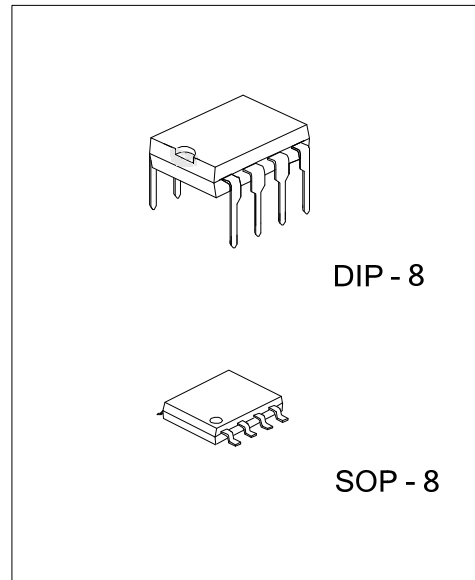

ORDERING INFORMATION

Ordering Number		Package	Packing
Lead Free	Halogen Free		
15600L-D08-T	15600G-D08-T	DIP-8	Tube
-	15600G-S08-R	SOP-8	Tape Reel

<p>15600L-D08-T</p> <ul style="list-style-type: none"> (1)Packing Type (2)Package Type (3)Green Package 	<ul style="list-style-type: none"> (1) R: Tape Reel, T: Tube (2) D08: DIP-8, S08: SOP-8 (3) L: Lead Free, G: Halogen Free and Lead Free
--	--

MARKING

DIP-8	SOP-8
<p> UTC □ □ □ □ → Date Code 1 5 6 0 0 □ → L: Lead Free □ □ → G: Halogen Free □ □ □ □ → Lot Code </p>	<p> UTC □ □ □ □ → Date Code 1 5 6 0 0 G □ → Lot Code </p>

PIN CONFIGURATION

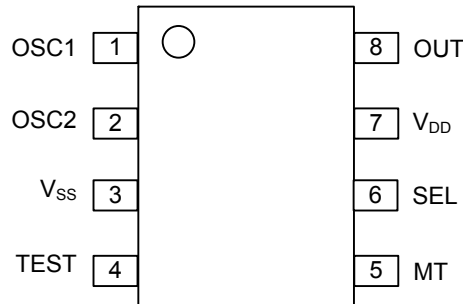

PIN DESCRIPTION

PIN NO	PIN NAME	I/O	DESCRIPTION
1	OSC1	I/NC	1. When the external clock mode is selected by mask option: Enter square waves of 32.768kHz or 47.520kHz to the OSC1 pin as the reference signal source. 2. When the integrated RC oscillation is selected by mask option: When using an external "R", insert a resistor between the OSC1 and OSC2 to adjust the oscillation frequency by the resistance of the resistor. When using integrated RC, keep the OSC1 and OSC2 open.
2	OSC2	O	
3	V _{SS}		Negative supply pin or grounding pin
4	TEST	I	Integrated pull down. when TEST is "high" and MT pin is "high, the device goes into test mode .when IC goes into working, test should be tied to V _{SS} .
5	MT	I	Integrated pull down . When "high" level is input, the device goes into working mode to control starting and stopping of the performance in accordance with the performance method being designated by the mask option, and that the device has the debounce circuitry inside, it is of no effect that the pulse is short of 32ms or 47ms.
6	SEL	I	Integrated pull down. Melody 1 and melody 2 can be selected in the binary code by entering "0" or "1" into this pin. "Changing the melody midway during performance –not possible or possible" is selected by mask option.
7	V _{DD}		Power supply
8	OUT	O	With the audio signals, the key melody and accompaniment, respectively, are attenuated under a certain time constant and respective outputs of the key melody and accompaniment are mixed by the mixing resistor before being output. This pin should therefore be connected to input pin of a pre-amp via a variable resistor for volume control , coupling-capacitor, etc

■ BLOCK DIAGRAM

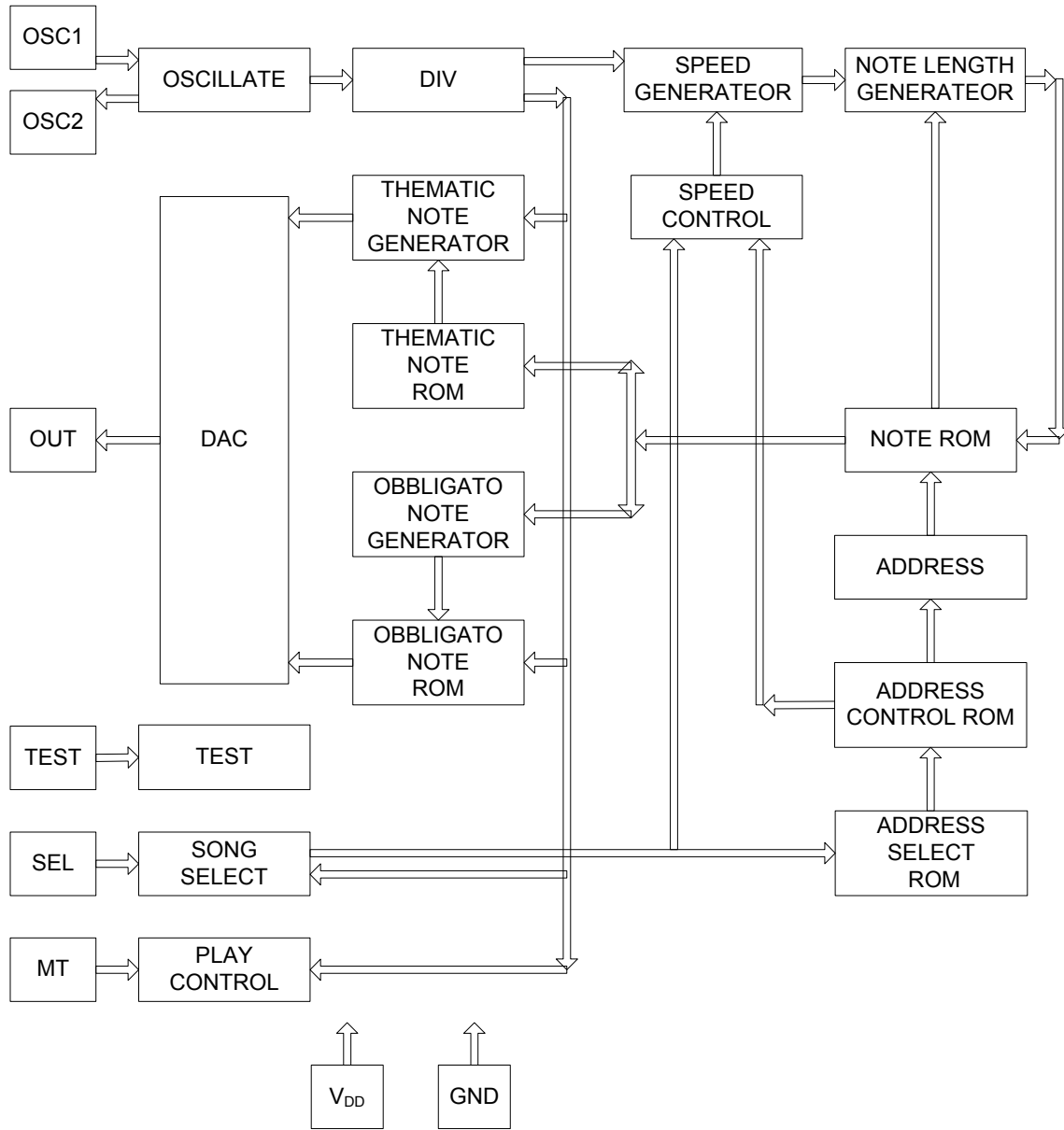

■ ABSOLUTE MAXIMUM RATING ($T_A=25^\circ\text{C}$, unless otherwise specified)

PARAMETER	SYMBOL	RATINGS	UNIT
Supply Voltage	V_{DD}	-0.3~+7.0	V
Terminal Voltage	V_{IO}	-0.2 ~ $V_{DD}+0.2$	V
Operating Temperature	T_{OPR}	-20 ~ +85	$^\circ\text{C}$
Storage Temperature	T_{STG}	-65 ~ +150	$^\circ\text{C}$

Note: Absolute maximum ratings are those values beyond which the device could be permanently damaged. Absolute maximum ratings are stress ratings only and functional device operation is not implied.

■ DC CHARACTERISTICS ($V_{DD}=0.9\sim 5.5\text{V}$, $V_{SS}=0\text{V}$, $T_A=25^\circ\text{C}$, $V_{DD}=15\text{V}$, unless otherwise specified))

PARAMETER	SYMBOL	PIN	TEST CONDITIONS	MIN	TYP	MAX	UNIT	
Working Voltage	V_{DD}	7	OSC1=32.768 or 47.520kHz Note 1.	0.9	3.0	5.5	V	
RC Oscillation Start Voltage	V_{STA}	7	RC built-in			0.9	V	
RC Oscillation Stop Voltage	V_{STP}	7	RC built-in			0.9	V	
High Level Input Voltage	V_{IH1}	5, 6	$V_{DD}=1.5\text{V} \sim 5.5\text{V}$	V_{DD} -0.3		V_{DD}	V	
		1	$V_{DD}=1.5\text{V} \sim 5.5\text{V}$, External clock signal input					
High Level Input Voltage	V_{IH2}	5, 6	$V_{DD}=0.9\text{V} \sim 1.5\text{V}$	V_{DD} -0.2		V_{DD}	V	
		1	$V_{DD}=0.9\text{V} \sim 1.5\text{V}$, External clock signal input					
Low Level Input Voltage	V_{IL1}	5, 6	$V_{DD}=1.5\text{V} \sim 5.5\text{V}$	0		0.3	V	
		1	$V_{DD}=1.5\text{V} \sim 5.5\text{V}$, External clock signal input					
Low Level Input Voltage	V_{IL2}	5, 6	$V_{DD}=0.9\text{V} \sim 1.5\text{V}$	0		0.3	V	
		1	$V_{DD}=0.9\text{V} \sim 1.5\text{V}$, External clock signal input					
High Level Input Current(1)	I_{IH1}	6	$V_{IH1}=V_{DD}$, standby mode			-0.3	μA	
		1	$V_{IH1}=V_{DD}$, External clock signal input					
High Level Input Current(2)	I_{IH2}	5	Working mode $V_{IH2}=V_{DD}$	$V_{DD}=1.5\text{V}$	0.4	1.8	4.0	μA
				$V_{DD}=3.0\text{V}$	3.0	10.0	30.0	
				$V_{DD}=5.0\text{V}$	12.5	32.0	80.0	
Low Level Input Current	I_{IL}	5, 6	$V_{IL}=0\text{V}$	-0.3			μA	
		1	$V_{IL}=0\text{V}$, External clock signal input					
Output Impedance	Z_{OUT}	8	When attacking both of the key melody and accompaniment at the same time and when determining the timing of respective DAC levels for them		222 (68)	440 (150)	$\text{k}\Omega$	
Internal Rating Voltage	$ V_{REG} $		$V_{DD}=1.5\sim 5.5\text{V}$		1.05	1.2	V	
Standby Mode Current Consumption	I_{DDS}	7	All input terminals =0V Out =No load, Standby mode		0.1	1.0	μA	

■ DC CHARACTERISTICS(Cont.)

PARAMETER	SYMBOL	PIN	TEST CONDITIONS	MIN	TYP	MAX	UNIT	
Working mode average current consumption(1)	I _{DDO}	7	MT=V _{DD} , SEL=TEST=0V When RC oscillation is selected: F _{CK} =32.768kHz or 47.520kHz OUT=No load Working mode	V _{DD} =1.5V		20	50~80	μA
				V _{DD} =3.0V		30~5 (Note2)	70~100 (Note2)	μA
				V _{DD} =5.0V		80~100 (Note2)	150~200 (Note2)	μA
			MT=V _{DD} , SEL=TEST=0V When external clock signal input OSC2=No load OSC1=32.768kHz or 47.520kHz, OUT=No load Working mode	V _{DD} =1.5V		20 (Note2)	50~80 (Note 2)	μA
				V _{DD} =3.0V		30~50 (Note2)	70~100 (Note2)	μA
				V _{DD} =5.0V		80~100 (Note2)	150~200 (Note2)	μA
Working mode average current consumption(2)	I _{DD}	7	MT= V _{DD} , SEL=TEST=0V When RC oscillation is selected: F _{CK} =32.768kHz or 47.520kHz OUT=No load Working mode After one-shot performance stops.	V _{DD} =1.5V		20	60	μA
				V _{DD} =3.0V		30	90	μA
				V _{DD} =5.0V		60	180	μA
			MT= V _{DD} SEL=TEST=0V When external clock signal input OSC2=No load OSC1=32.768kHz or 47.520kHz OUT=No load Working mode After one-shot performance stops.	V _{DD} =1.5V		10	40	μA
				V _{DD} =3.0V		20	70	μA
				V _{DD} =5.0V		45	160	μA

Note: 1. Under the RC oscillation mode. When the supply voltage drops below the voltage being generated the internal constant voltage circuit, the RC oscillation frequency goes down below the prescribed level to reduce the tempo and to bring down the pitch corresponding to the downward deviation of the oscillation frequency. Other circuits function normally under the prescribed specifications.

2. This value is a reference value. Because current consumption varies depending on the programmed pitch, tempo, used notes and address location with each ROM.

■ DC CHARACTERISTICS (5.5V≥V_{DD}≥V_{DD}-V_{REG}, T_A=25°C)

PARAMETER	SYMBOL	CONDITION	SPEC			UNIT	
			MIN	TYP	MAX		
When the External Clock Mode is Selected by Mask Option: Enter Square Waves to the OSC1 Pin as the Reference Signal Source.	f _{EXC}	External signal clock input	-15	32.768	+15	%	
			27.853		47.520	37.683	KHZ
			40.392		54.648	KHZ	
RC Oscillation Frequency Times	f _{OSC}	The integrated RC oscillation	-15	32.768	+15	%	
			27.853		47.520	37.683	KHZ
			40.392		54.648	KHZ	

■ BASIC EXTERNAL CONNECTION DIAGRAM

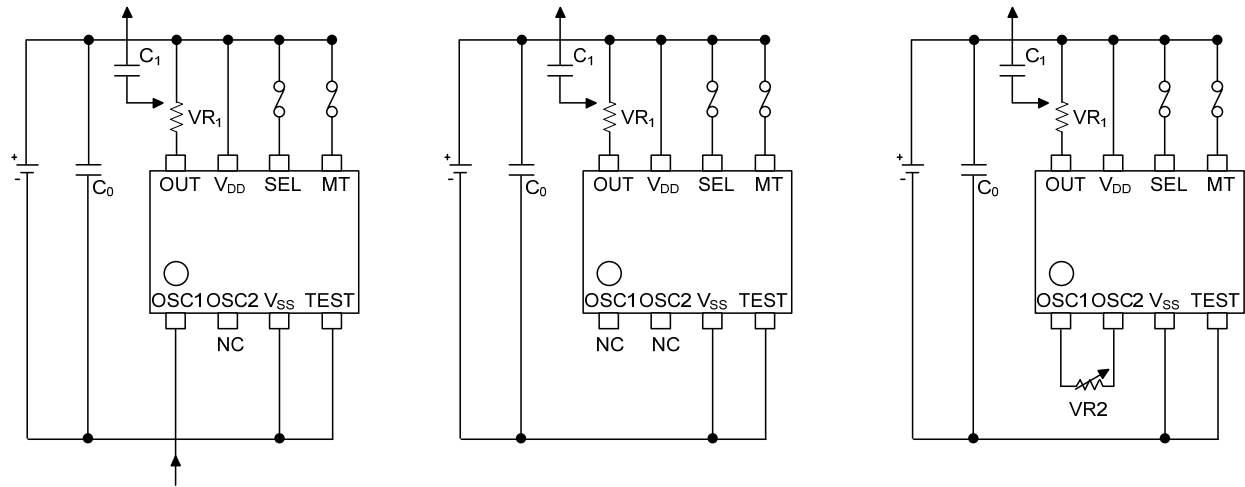

■ REFERENCE CIRCUIT CONSTANTS

REMARKS	SYMBOL	REFERENCE VALUES	UNIT
Volume Controlling Variable Resistor	VR ₁	100 ~ 500	KΩ
External Resistor of the RC Oscillation	VR ₂	0 ~ 1	MΩ
Power Stabilizing Capacitor	C ₀	1 ~ 100	μF
Audio Output Coupling Capacitor	C ₁	0.1	μF

UTC assumes no responsibility for equipment failures that result from using products at values that exceed, even momentarily, rated values (such as maximum ratings, operating condition ranges, or other parameters) listed in products specifications of any and all UTC products described or contained herein. UTC products are not designed for use in life support appliances, devices or systems where malfunction of these products can be reasonably expected to result in personal injury. Reproduction in whole or in part is prohibited without the prior written consent of the copyright owner. The information presented in this document does not form part of any quotation or contract, is believed to be accurate and reliable and may be changed without notice.