

Thick Film Chip Dividers, High Voltage

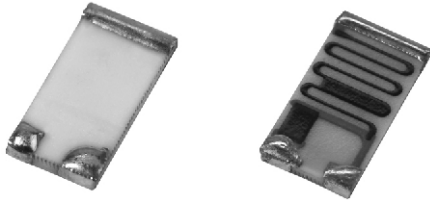

FEATURES

- High voltage up to 3000 V
- Typical resistance ratios of 250:1 to a maximum resistance ratio of 500:1
- Flow solderable
- Tape and reel packaging available
- Termination style: 3-sided wraparound termination or single termination flip chip available
- Suitable for solderable, epoxy bondable, or wire bondable applications
- Termination material: solder-coated nickel barrier or solder coated non-magnetic terminations standard; gold, palladium silver, platinum gold, platinum silver or platinum palladium gold terminations available
- Multiple styles, termination materials and configurations, allow wide design flexibility
- Epoxy bondable or wire bondable non-magnetic terminations available
- Material categorization: for definitions of compliance please see www.vishay.com/doc?99912



LINKS TO ADDITIONAL RESOURCES



Note

* This datasheet provides information about parts that are RoHS-compliant and / or parts that are non-RoHS-compliant. For example, parts with lead (Pb) terminations are not RoHS-compliant. Please see the information / tables in this datasheet for details

STANDARD ELECTRICAL SPECIFICATIONS

GLOBAL MODEL	CASE SIZE	POWER RATING $P_{70\text{ }^{\circ}\text{C}}$ W	MAXIMUM WORKING VOLTAGE ⁽¹⁾ V	RESISTANCE RANGE ⁽²⁾ Ω	TOLERANCE ⁽³⁾ $\pm \%$	TEMPERATURE COEFFICIENT ⁽⁴⁾ (-55 °C to +155 °C) $\pm \text{ppm}/^{\circ}\text{C}$	TCR TRACKING $\pm \text{ppm}/^{\circ}\text{C}$
CDHV 2512	2512	1	3000	20M to 20G	1, 2, 5, 10, 20	100	50 (typical)

Notes

- (1) Continuous working voltage shall be $\sqrt{P \times R}$ or maximum working voltage, whichever is less
- (2) Resistance values below 1 G Ω are calibrated at 100 V_{DC}, and values of 1 G Ω and above are calibrated at 1000 V_{DC}. Calibration at other voltages available upon request
- (3) Contact factory for tighter tolerances
- (4) Reference only: not for all values specified. Consult factory for your value

VOLTAGE AND TEMPERATURE COEFFICIENTS OF RESISTANCE CHART TYPICAL

RESISTANCE (Ω)	RATIO (TYPICAL)	VCR (ppm/V)	TCR (ppm/°C) -55 °C to +155 °C
20M	250:1	10	100
150M	300:1	10	150
800M	500:1	10	200

Note

- Contact factory for other ratios

GLOBAL PART NUMBER INFORMATION

New Global Part Numbering: CDHVAF20M0J2500GFB (preferred part number format)

C	D	H	V	A	F	2	0	M	0	J	2	5	0	0	G	F	B
----------	----------	----------	----------	----------	----------	----------	----------	----------	----------	----------	----------	----------	----------	----------	----------	----------	----------

GLOBAL MODEL	TERM STYLE	TERM MATERIAL	RESISTANCE VALUE (R ₁)	TOLERANCE	RATIO (R ₁ + R ₂) / R ₂	RATIO TOLERANCE	SOLDER TERMINATION	PACKAGING
CDHV = CDHV2512	A = 3-sided B = top only	F = nickel barrier G = non-magnetic A = palladium silver B = platinum gold C = gold D = platinum silver E = platinum palladium gold	M = MΩ G = GΩ 20M0 = 20 MΩ 800M = 800 MΩ 1G00 = 1 GΩ	F = ± 1 % G = ± 2 % J = ± 5 % K = ± 10 % M = ± 20 %	3 digit significant figure, followed by a multiplier 0500 = 50:1 2500 = 250:1 3000 = 300:1 5000 = 500:1	G = ± 2 % H = ± 3 % J = ± 5 %	E = Sn100 F = Sn95/Ag5, HSD N = no solder S = Sn62 / Pb36 / Ag2, HSD T = Sn90 / Pb10	B = bulk (250 pcs max.) F = T / R (full reel) 1 = T / R (1000 pcs) 5 = T / R (500 pcs) T = T / R (250 pcs min.) W = waffle tray

Historical Part Numbering: CDHV2512AF2005J2500Ge2 (will continue to be accepted)

CDHV2512	A	F	2005	J	2500	G	e2
HISTORICAL MODEL	TERM STYLE	TERM MATERIAL	RESISTANCE VALUE (R ₁)	TOLERANCE	RATIO (R ₁ + R ₂) / R ₂	RATIO TOLERANCE	SOLDER TERMINATION

Note

- For additional information on packaging, refer to the “Surface Mount Resistor Packaging” document (www.vishay.com/doc?31543)

MATERIAL SPECIFICATIONS

Resistive element	Ruthenium oxide
Encapsulation	Glass
Substrate	96 % alumina
Termination	Solder-coated nickel barrier or solder coated non-magnetic terminations standard. Gold, palladium silver, platinum gold, platinum silver, platinum palladium gold terminations available.
Solder finish	Pure tin or tin / lead solder alloys standard. Tin / silver or tin / lead / silver solder alloys available.

ENVIRONMENTAL SPECIFICATIONS

Operating temperature	-55 °C to +155 °C
Life	Less than 0.5 % change when tested at full rated power

Note

- Reference only: not for all values specified. Consult factory for your size and value

DIMENSIONS in inches (millimeters)

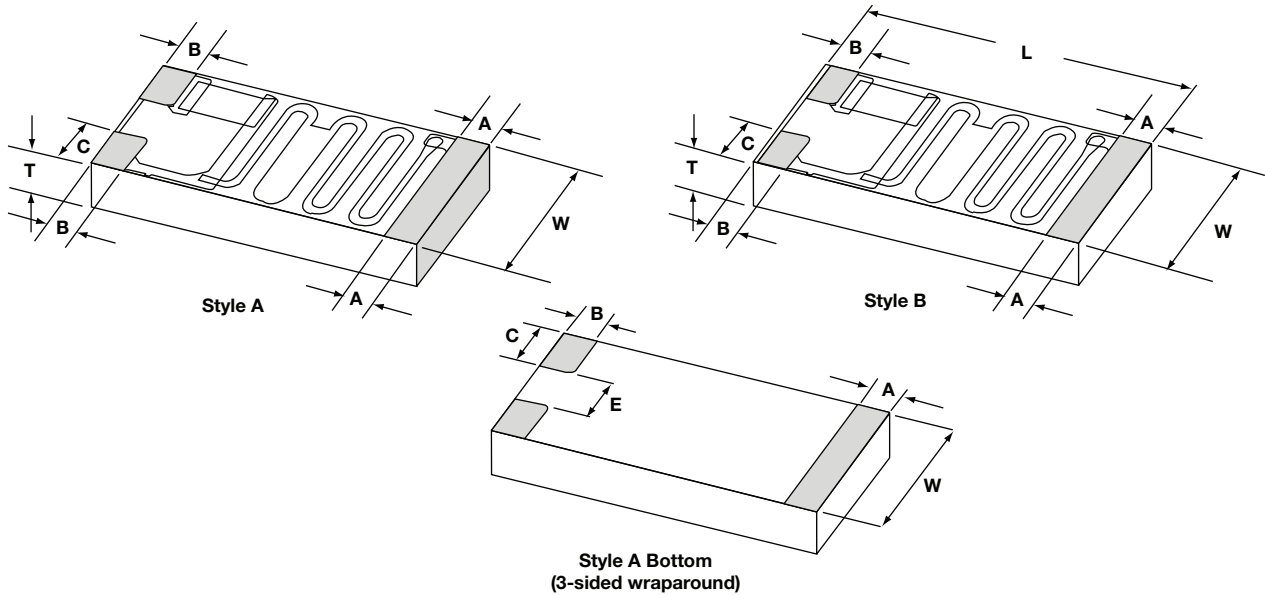

TERMINATION	LENGTH (L) ± 0.006 (0.152)	WIDTH (W) ± 0.006 (0.152)	THICKNESS (T) ± 0.005 (0.127)	A ± 0.005	B ± 0.005	C ± 0.005	E ± 0.005
Style A (3-sided wraparound)	0.250	0.126	0.025	0.025	0.025	0.040	0.046
Style B (top only)	0.240	0.126	0.025	0.025	0.025	0.040	-

DERATING CURVE

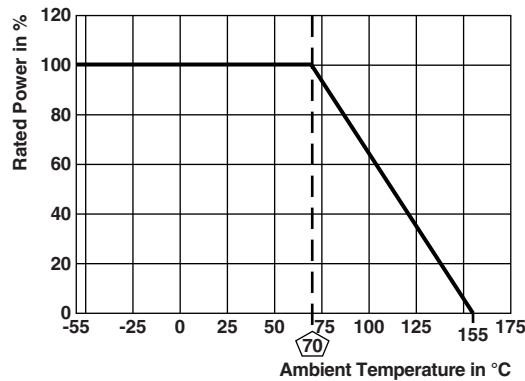

Note

- Reference only: not for all values specified. Consult factory for your specific value

TYPE	TERMINATION MATERIAL	TERMINATION STYLE	TERMINATION STYLE / MATERIAL CODE	SOLDER TERMINATION CODE
Solderable	Nickel barrier	3-sided (wraparound)	AF	E or T (standard); F or S (optional) ⁽¹⁾
		Top only (flip chip)	BF	
Solderable	Non-magnetic	3-sided (wraparound)	AG	E or T (standard); F or S (optional) ⁽¹⁾
		Top only (flip chip)	BG	
Epoxy bondable / solderable	Platinum palladium gold	Top only (flip chip)	BE	N (standard); F or S (optional) ⁽²⁾
Wire bondable / epoxy bondable	Gold	Top only (flip chip)	BC	N
Epoxy bondable	Palladium silver ⁽³⁾	Top only (flip chip)	BA	N
	Platinum gold		BB	
	Platinum silver		BD	

Notes

- (1) Standard solder plating for the nickel barrier and non-magnetic parts is solder terminations E or T. Hot solder dipped terminations F or S are also available
- (2) Use solder termination N for applications requiring epoxy bondable mounting, and solder terminations F or S for applications requiring solderable mounting
- (3) While not recommended, palladium silver terminations could be used for solderable applications when using a solder alloy containing silver. If the solder paste being used to solder the palladium silver terminated parts to the boards does not have a silver-based composition, then the silver in the terminations could begin to leach when it is exposed to liquidus non-silver-based solders, causing the potential for solderability and/or solder joint issues

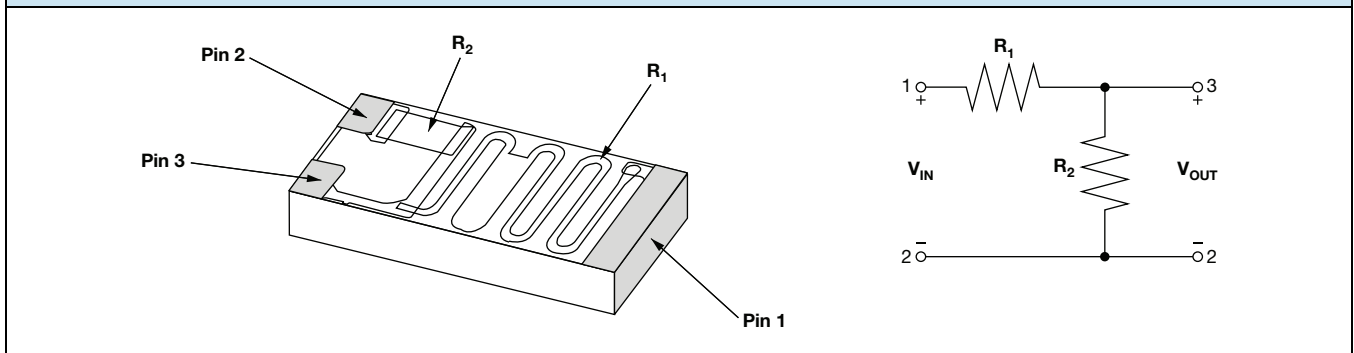
SCHEMATIC



Disclaimer

ALL PRODUCT, PRODUCT SPECIFICATIONS AND DATA ARE SUBJECT TO CHANGE WITHOUT NOTICE TO IMPROVE RELIABILITY, FUNCTION OR DESIGN OR OTHERWISE.

Vishay Intertechnology, Inc., its affiliates, agents, and employees, and all persons acting on its or their behalf (collectively, "Vishay"), disclaim any and all liability for any errors, inaccuracies or incompleteness contained in any datasheet or in any other disclosure relating to any product.

Vishay makes no warranty, representation or guarantee regarding the suitability of the products for any particular purpose or the continuing production of any product. To the maximum extent permitted by applicable law, Vishay disclaims (i) any and all liability arising out of the application or use of any product, (ii) any and all liability, including without limitation special, consequential or incidental damages, and (iii) any and all implied warranties, including warranties of fitness for particular purpose, non-infringement and merchantability.

Statements regarding the suitability of products for certain types of applications are based on Vishay's knowledge of typical requirements that are often placed on Vishay products in generic applications. Such statements are not binding statements about the suitability of products for a particular application. It is the customer's responsibility to validate that a particular product with the properties described in the product specification is suitable for use in a particular application. Parameters provided in datasheets and / or specifications may vary in different applications and performance may vary over time. All operating parameters, including typical parameters, must be validated for each customer application by the customer's technical experts. Product specifications do not expand or otherwise modify Vishay's terms and conditions of purchase, including but not limited to the warranty expressed therein.

Hyperlinks included in this datasheet may direct users to third-party websites. These links are provided as a convenience and for informational purposes only. Inclusion of these hyperlinks does not constitute an endorsement or an approval by Vishay of any of the products, services or opinions of the corporation, organization or individual associated with the third-party website. Vishay disclaims any and all liability and bears no responsibility for the accuracy, legality or content of the third-party website or for that of subsequent links.

Except as expressly indicated in writing, Vishay products are not designed for use in medical, life-saving, or life-sustaining applications or for any other application in which the failure of the Vishay product could result in personal injury or death. Customers using or selling Vishay products not expressly indicated for use in such applications do so at their own risk. Please contact authorized Vishay personnel to obtain written terms and conditions regarding products designed for such applications.

No license, express or implied, by estoppel or otherwise, to any intellectual property rights is granted by this document or by any conduct of Vishay. Product names and markings noted herein may be trademarks of their respective owners.